



Precision PF-1U-FA 8 or 16-Channel Filter/Amplifier Systems

The **PF-1U-FA Multi-Channel Programmable Filter/Amplifier System** is ideal for conditioning low-level voltage inputs in front of high-resolution digital data acquisition systems. Fully programmable 8-channel and 16-channel configurations are available in standard or high-performance models. A choice of 4 and 8-pole filter characteristics is available in low-pass and band-pass configurations. Fully programmable gain is distributed around the filter to reduce the possibility of clipping on out-of-band signals.



PF-1U-FA Description

The PF-1U-FA series is a multi-channel programmable filter/amplifier system in a compact rack mountable or bench top package. Fully programmable 8-channel and 16-channel configurations are available in high performance or standard configurations.

The standard PF-1U-FA configuration offers 4-pole low-pass filters with five programmable cutoffs and gain programmable to x1,024.

The high performance PF-1U-FA offers a choice of 4 or 8-pole low-pass and band-pass filters with cutoffs programmable from 1 Hz to 204.6 kHz. The high performance PF-1U-FA has an upgraded wideband (500 kHz) low-noise amplifier with transducer DC suppress capability. Gain is programmable to x8,192.

Applications

- Spectral analysis
- Time domain wave analysis
- Transient shock measurements
- Anti-aliasing filters with programmable amplifiers
- Automatic test equipment
- Data acquisition
- Signal conditioning
- Production test equipment
- Reconstruction filters
- Industrial process control
- Programmable band-pass filters

The “flat” mode provides passband characteristics nearly identical to a Butterworth filter while providing a much sharper roll-off. This mode is a good choice for applications such as spectral analysis. The “pulse” mode has time domain response similar to the Bessel filter yet provides superior amplitude response characteristics. The “pulse” mode is ideal for time domain applications including transient (shock) measurements and waveform analysis.

Gain is distributed both before and after the filter to provide protection from large out-of-band energy or transients that could cause clipping before the filter, distorting the data. The post-filter gain has resolution of better than 0.05% to enable system scaling of the outputs to match the full-scale input of the external recording device. Overload detectors alert the user to over-voltage conditions.

Other features of the PF-1U-FA include a test input for injection of calibration signals into the channel input and a monitor output that allows for convenient monitoring of any channel output via a single BNC.

The system includes an Ethernet remote interface and is supplied with a Windows based Graphical User Interface (GUI) for local control.

Salient Features

Number of Channels:

- 16 (PF-1U-16FA)
- 8 (PF-1U-8FA)

Input Connectors:

- Individual isolated BNC's at front panel

Output Connectors:

- Individual BNC's at rear panel

Inputs:

- Balanced differential with programmable AC/DC coupling

Zero Suppress (High Performance PF-1U-FA):

- Programmable DC voltage is inserted at channel input

Pre-Filter Gain:

- High Performance PF-1U: x1 to x512 in x2 steps
- Standard PF-1U: x1 to x64 in x2 steps

Post-Filter Gain:

- High Performance PF-1U: x0.25 to x16 with 0.05% resolution
- Standard PF-1U: x0.5 to x16 with 0.05% resolution

High Performance PF-1U-FA Filters:

- Choice of 4 or 8-pole low-pass flat/pulse filters or 8-pole band-pass filters

Cutoff Frequency (High Performance PF-1U-FA):

- Pulse Mode programmable from 1 Hz to 102.3 kHz
- Flat Mode programmable from 2 Hz to 204.6 kHz
- Wideband 500 kHz, typical

Standard PF-1U-FA Filters:

- 4-pole low-pass filters

Cutoff Frequency (Standard PF-1U-FA):

- FX01: 100 Hz, 300 Hz, 1 kHz, 3 kHz, 10 kHz, Wideband (190 kHz)
- FX02: 300 Hz, 1 kHz, 3 kHz, 10 kHz, 30 kHz, Wideband (190 kHz)

Outputs:

- DC coupled, single-ended

Test Support:

- Test input and monitor output busses

Input Power:

- 12 to 24 VDC external AC to DC power supply provided with unit

Control:

- Ethernet remote control
- Local control via supplied Windows based Graphical User Interface (GUI)
- Store up to four setups in non-volatile RAM allowing pre-configured applications

PF-1U-FA Filter Characteristics

You want your analog data to come clean before digital conversion.

The PF-1U-FA System has a variety of high performance filter characteristics available for LP or BP Precision filtering.

Flat/Pulse Low-Pass Filters

Our new choice of LP4FP 4-pole or LP8FP 8-pole flat/pulse low-pass filters provide the user with the versatility to address applications in either the time or frequency domain and are available on both the 8 and 16-channel systems.

LP4F and LP4P Amplitude Response

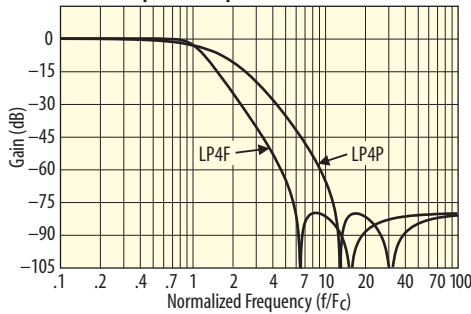

LP8F and LP8P Amplitude Response

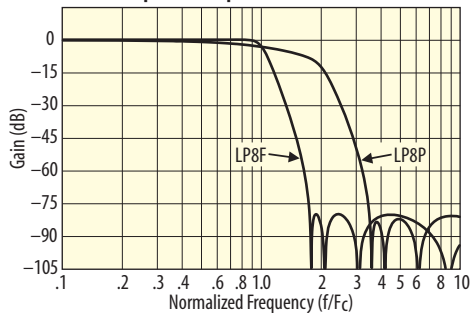

Flat Mode Low-Pass Filters

Precision LP4F and LP8F "flat" mode characteristics are specified to have outstanding passband flatness equivalent to the Butterworth yet deliver very sharp roll-off characteristics.

LP4F and LP8F vs Butterworth Amplitude Response

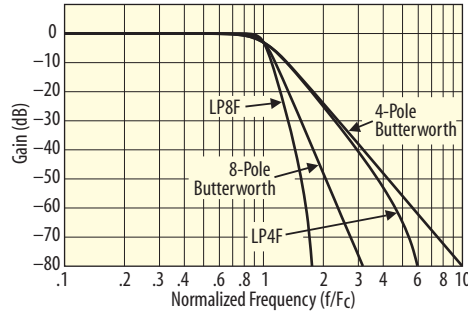

The LP4F and LP8F are a good choice as an anti-aliasing filter and for applications such as spectral analysis. The LP8F has zero passband ripple and over 100 dB/octave attenuation slope.

LP4F and LP8F vs Butterworth Passband Response

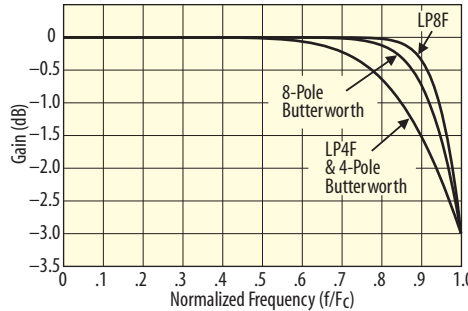

Pulse Mode Low-Pass Filters

For the time domain, there are the LP4P and LP8P "pulse" mode low-pass filters. These filters have excellent transient response and phase linearity making them ideal filters for time domain applications including transient (shock) measurements and time domain waveform analysis ... all with roll-off characteristics superior to their Bessel filter counterparts.

LP8P vs 8-Pole Bessel Amplitude Response

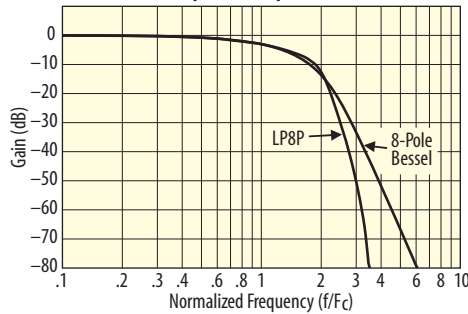

LP8P and LP4P Passband Response

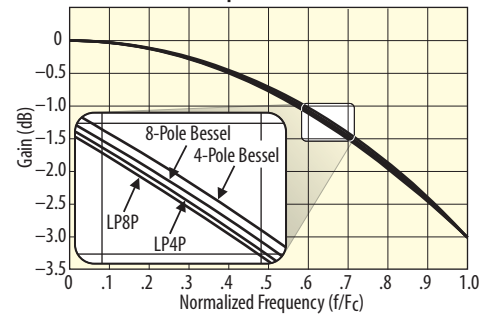

LP8P and LP4P Step Response

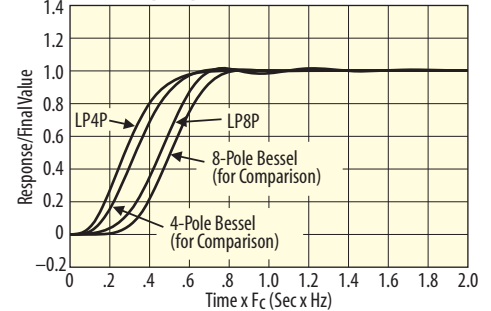

Band-Pass Filters

For band-pass filtering, choose the HP4F/LP4FP band-pass characteristic to provide programmable bandwidth and center frequency filters.

Band-Pass Amplitude Response HP4F and LP4F Cascaded

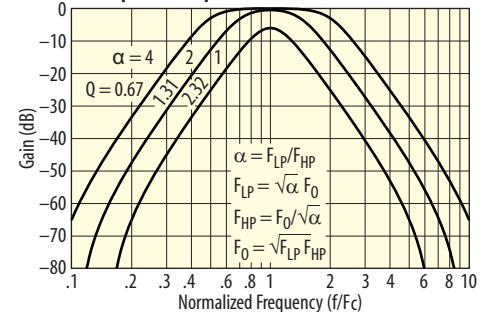

Operating the PF-1U-FA

System Control

For local control, the PF-1U-FA system is controlled via an Ethernet interface using the supplied spreadsheet-style GUI application running on a Windows PC. The GUI supports control of all channel and system features and allows for group control of channels. Up to eight PF-1U-FA systems can be controlled by one GUI. System settings are restored on power-up or after a power fault. The settings are retained when the computer is disconnected even after a power-down and up, allowing the unit to be pre-configured for an application in which a computer may not be available for control.

The PF-1U-FA system may be controlled remotely via an interactive command line interpreter that allows the PF-1U-FA to function as a server on the network.

Controls, Indicators and Connectors

Front Panel

Analog Input Connectors:

PF-1U-8FA – Eight coaxial BNC Input connectors provide input connection to channels 0 through 7.

PF-1U-16FA – Sixteen coaxial BNC Input connectors provide input connection to channels 0 through 15.

Input Overload Indicators:

Overload LEDs, one above each channel input connector, indicate an input overload condition.

Test Input Connector:

The coaxial BNC Test Input Connector provides a means to connect an external test signal from a programmable function generator to the channel inputs without disconnecting input signal cables.

The Warning LED indicates a system fault such as over temperature or a power voltage out of factory specifications.

Power Switch and Indicator:

The On/Off Power Switch is located on the front panel and includes a Power On LED indicating when the system is powered up.

Ethernet Connector:

The RJ45 Ethernet connector provides the control link for a host computer and includes a Status LED indicating the host is communicating with the system.

Rear Panel

Analog Output Connectors:

PF-1U-8FA – Eight coaxial BNC Output connectors provide output connection to channels 0 through 7.

PF-1U-16FA – Sixteen coaxial BNC Output connectors provide output connection to channels 0 through 15.

Power In Connector:

The Power In Connector provides a connection for an external DC power supply.

Chassis Ground and Signal Ground Posts:

The Chassis Ground post and the Signal Ground post provide a means for coupling the chassis ground to the signal ground.

Monitor Output Connector:

The coaxial BNC Monitor Output connector provides a means for viewing the output of a selected channel using a scope or other measurement device without disconnecting output signal cables.

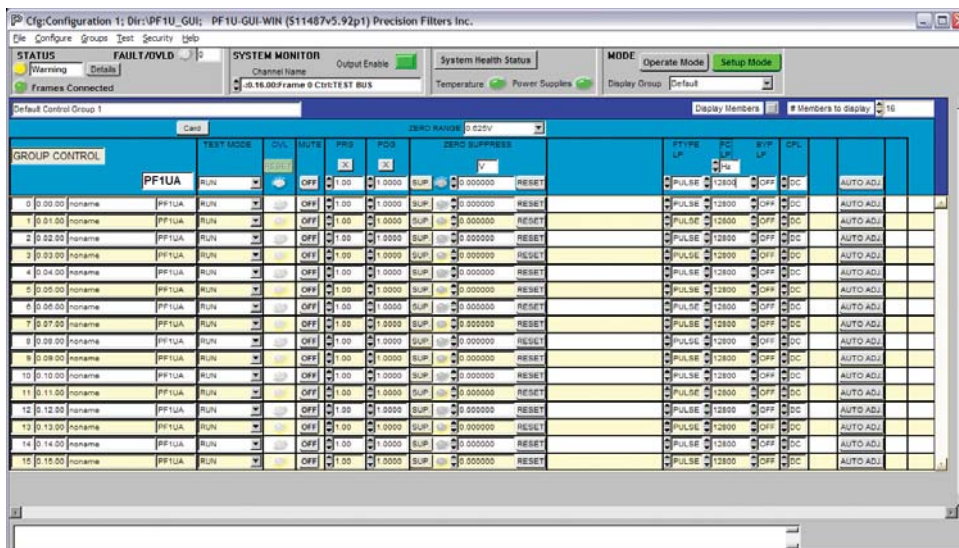

PF1U-GUI

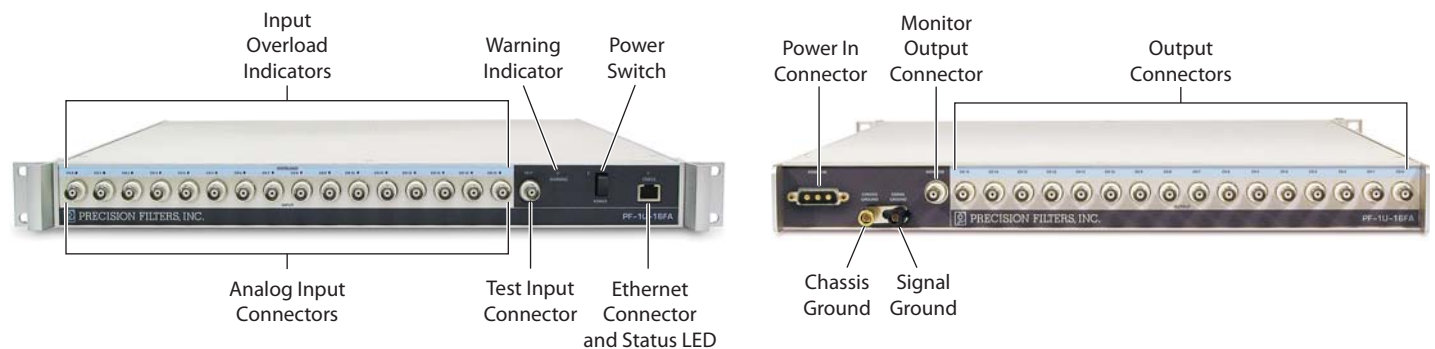

PF-1U-16FA Front Panel

PF-1U-16FA Rear Panel

PF-1U-FA Details and Specifications

PF-1U-FA Filter/Amplifier System

The detailed description and specifications for the PF-1U-FA are organized as follows in the sections below:

- Input Characteristics
- Amplifier Specifications
- Filter Type Characteristics
- Output Characteristics
- Power Requirements
- PF-1U Standard vs. High Performance Comparison Table
- PF-1U-FA General Characteristics
- Accessories
- Ordering Information

Input Characteristics

Type:

Balanced Differential w/ programmable AC/DC input coupling

Input Connector:

Individual BNC's at front panel

Input Impedance:

10 M Ω //100 pF per side

Max Level:

(AC + DC + Common Mode)
 ± 10 Vpk for $f < \text{or} = 200$ kHz
 ± 10 Vpk x (200 kHz/f) for $f > 200$ kHz

Input Protection:

25 V continuous (power on)
60 Vpk transient (1 ms pulse,
50% duty cycle)

Offset Drift:

High Performance PF-1U-FA:
1 $\mu\text{V}/^\circ\text{C}$, typical
Standard PF-1U-FA: 10 $\mu\text{V}/^\circ\text{C}$, typical

Noise:

High Performance PF-1U-FA:
7 nV per rt. Hz at 1 kHz and pre-filter gain > 64, typical
Standard PF-1U-FA: 14 nV per rt. Hz at 1 kHz and pre-filter gain > 64, typical

AC Coupling Frequency:

High Performance PF-1U-FA:
0.25 Hz (-3.01 dB)
Standard PF-1U-FA: 0.5 Hz (-3.01 dB)

CMRR (DC Coupled):

86 dB, DC to 440 Hz and input gain > x8

CMRR (AC Coupled):

80 dB, 10 Hz to 440 Hz and input gain > x8

Input Short:

Amplifier inputs may be programmed to ground to measure amplifier noise and DC offset.

Test Input:

A switch at the channel input allows for injection of external test signal via an external front panel BNC connector.

Zero Suppress

(High Performance PF-1U-FA Only):

Precision programmable DC offset is injected at the channel input stage to suppress the DC operating voltage. Manual or automatic suppression modes are supported (Standard).

0.64 V Suppress Ranges:

± 0.01 mV to ± 10 mV in ± 4.88 μV steps
 ± 10.04 mV to ± 80 mV in ± 39 μV steps
 ± 80.30 mV to ± 0.64 V in ± 312 μV steps

10.24 V Suppress Ranges

(Gain limited to x 256):
 ± 0.08 mV to ± 160 mV in ± 78 μV steps
 ± 160.6 mV to ± 1.28 V in ± 625 μV steps
 ± 1.285 V to ± 10.24 V in ± 5 mV steps

Accuracy:

$\pm 0.25\%$ of setting ± 5 mV

Amplifier Specifications (High Performance PF-1U-FA)

Pre-Filter Gain:

x1 to x512 in x2 steps with overload detection (10.2 Vpk threshold)

Post-Filter Gain:

x0.25 to x16 with 0.05% resolution

DC Accuracy:

0.2%

Temperature Coefficient:

$\pm 0.008\%$ / $^\circ\text{C}$

DC Linearity:

$\pm 0.01\%$ re: Fullscale, relative to best straight line

Frequency Response:

DC to 200 kHz; 0 dB ± 0.1 dB;
-3 dB typical at 500 kHz

Amplifier Specifications (Standard PF-1U-FA)

Pre-Filter Gain:

x1 to x64 in x2 steps with overload detection (10.2 Vpk threshold)

Post-Filter Gain:

x0.5 to x16 with 0.05% resolution

DC Accuracy:

0.2%

Temperature Coefficient:

$\pm 0.008\%$ / $^\circ\text{C}$

DC Linearity:

$\pm 0.01\%$ re: Fullscale, relative to best straight line

Frequency Response:

DC to 100 kHz; 0 dB ± 0.1 dB;
-3 dB typical at 190 kHz



PF-1U-8FA 8-Channel Filter/Amplifier System
Front Panel



PF-1U-8FA 8-Channel Filter/Amplifier System
Rear Panel

PF-1U-FA Details and Specifications

PF-1U-FA Filter Type Characteristics

Option LP4FP:

4-pole, 4-zero low-pass filter.
Programmable for maximally flat pass-band (LP4F) or linear phase with optimized pulse response (LP4P).

Option LP8FP

(High Performance PF-1U-FA Only):

8-pole, 8-zero low-pass filter.
Programmable for maximally flat pass-band (LP8F) or linear phase with optimized pulse response (LP8P).

Option HP4F/LP4FP

(High Performance PF-1U-FA Only):

8-pole, 8-zero band-pass filter.
Flat HP4F 4-pole, 4-zero high-pass filter cascaded with a 4-pole, 4-zero low-pass filter. Low-pass filter programmable for maximally flat pass-band (LP4F) or linear phase with optimized pulse response (LP4P).

Cutoff Frequencies

(High Performance PF-1U-FA):

Flat Mode: LP4F, LP8F, HP4F

2 Hz to 2.046 kHz in 2 Hz steps
2.2 kHz to 204.6 kHz in 200 Hz steps

Pulse Mode: LP4P, LP8P

1 Hz to 1.023 kHz in 1 Hz steps
1.1 kHz to 102.3 kHz in 100 Hz steps

Cutoff Frequencies (Standard PF-1U-FA):

LP4F, LP4P

FX01: 100 Hz, 300 Hz, 1 kHz, 3 kHz, 10 kHz
FX02: 300 Hz, 1 kHz, 3 kHz, 10 kHz, 30 kHz

LP4F, LP4P, LP8F, LP8P:

Amplitude Accuracy:

±0.1 dB max, DC to 0.8 Fc
±0.2 dB max, 0.8 Fc to Fc

Amplitude Match:

±0.1 dB max, DC to 0.8 Fc
±0.2 dB max, 0.8 Fc to Fc

Phase Match:

±1° max, DC to 0.8 Fc
±2° max, 0.8 Fc to Fc

HP4F

(High Performance PF-1U-FA Only):

Amplitude Accuracy:

±0.1 dB max, 1.2 Fc to 204.6 kHz
±0.2 dB max, Fc to 1.2 Fc

Amplitude Match:

±0.1 dB max, 1.2 Fc to 204.6 kHz
±0.2 dB max, Fc to 1.2 Fc

Phase Match:

±1° max, 1.2 Fc to 204.6 kHz
±2° max, Fc to 1.2 Fc

Bypass:

Bypasses filter but not amplifier stages.
Each filter may be independently bypassed for the HP4F/LP4FP band-pass filter.

Bypass Bandwidth:

High Performance PF-1U-FA:
500 kHz, typical
Standard PF1U-FA:
190 kHz, typical

Specification	LP4F Maximally Flat Low-Pass Filter	LP4P Constant Time Delay Low-Pass Filter	LP8F Maximally Flat Low-Pass Filter	LP8P Constant Time Delay Low-Pass Filter	HP4F Maximally Flat High-Pass Filter
Cutoff Frequency Amplitude	-3.01 dB	-3.01 dB	-3.01 dB	-3.01 dB	-3.01 dB
DC Gain	0.00 dB	0.00 dB	0.00 dB	0.00 dB	-80 dB
Pass-Band Ripple	0.00 dB	0.00 dB	0.00 dB	0.00 dB	0.00 dB
Stop-Band Frequency	5.9465 Fc	11.863 Fc	1.7479 Fc	3.4688 Fc	0.1682 Fc
Cutoff Frequency Phase	-180.0 deg	-101.5 deg	-360 deg	-161.9 deg	180 deg
Phase Distortion (DC to Fc)	< 31.8 deg	< 3.7 deg	< 102 deg	< 0.05 deg	-
Zero Frequency Group Delay	0.4117/Fc	0.2920/Fc	0.7197/Fc	0.4496/Fc	-
Percent Overshoot	11.1%	0.5%	18.9%	1.1%	-
1% Settling Time	1.65/Fc	0.66/Fc	4.03/Fc	1.25/Fc	1.86/Fc
0.1% Settling Time	2.72/Fc	0.77/Fc	7.02/Fc	2.25/Fc	2.92/Fc
-0.1 dB Frequency	0.6348 Fc	0.1816 Fc	0.8538 Fc	0.1800 Fc	1.5753 Fc
-1 dB Frequency	0.8487 Fc	0.5742 Fc	0.9437 Fc	0.5685 Fc	1.1783 Fc
-2 dB Frequency	0.9370 Fc	0.8129 Fc	0.9772 Fc	0.8087 Fc	1.0672 Fc
-3.01 dB Frequency	1.0000 Fc	1.0000 Fc	1.0000 Fc	1.0000 Fc	1.0000 Fc
-20 dB Frequency	1.7412 Fc	3.0248 Fc	1.2149 Fc	2.2342 Fc	0.5743 Fc
-40 dB Frequency	2.9555 Fc	5.6932 Fc	1.4443 Fc	2.7556 Fc	0.3384 Fc
-60 dB Frequency	4.5986 Fc	9.0980 Fc	1.6391 Fc	3.2016 Fc	0.2175 Fc
-80 dB Frequency	5.9465 Fc	11.8629 Fc	1.7479 Fc	3.4688 Fc	0.1682 Fc

PF-1U-FA Details and Specifications

Output Characteristics

- Type:**
DC coupled, single ended output
- Output Connector:**
Individual BNC's at rear panel
- Impedance:**
10 Ω // 100 pF
- Max Output:**
 ± 10 Vpk, ± 10 mA pk
- Offset:**
<5 mV after auto-adjust at any gain setting
- Offset Drift:**
High Performance PF-1U-FA:
1 μ V/ $^{\circ}$ C, RTI + 150 μ V/ $^{\circ}$ C RTO
Standard PF-1U-FA:
10 μ V/ $^{\circ}$ C, RTI + 150 μ V/ $^{\circ}$ C RTO
- Crosstalk:**
-90 dB, DC to 100 kHz

- Noise:**
High Performance PF-1U-FA:
2.8 μ V rms RTI + 60 μ V rms RTO
3 Hz to 100 kHz
Standard PF-1U-FA:
7 μ V rms RTI + 100 μ V rms RTO
3 Hz to 100 kHz

Output Monitor:

A switch at the output of each channel allows for multiplexed connection to the chassis output monitor bus BNC connector for viewing the channel output with an external device.

Power Requirements

Power is supplied to the PF-1U-FA from either the external PF-1U-ACDC2-120W, included with each system, or a direct power source. The input power supply requirements are 12 VDC to 24 VDC, 75 W typical, and is applied at the rear panel POWER IN connector. Power supply mating connectors and pigtail mating connectors are available for custom applications. See Accessories on the last page for description and part numbers.

PF-1U-ACDC2 External Power Supply

The compact PF-1U-ACDC2-120W AC to DC external power supply features a thermostatically controlled cooling fan and carries the CE/UL listing marks. One PF-1U-ACDC2-120W is supplied with each PF-1U-FA system.

- Input Voltage, Frequency**
100-240 VAC, 47 to 63 Hz
- Current**
3.2 amp, 100-120 VAC,
2.0 amp, 220-240 VAC

PF-1U Standard vs. High Performance Comparison Table

	PF-1U Standard Performance	PF-1U High Performance
Gain	Overall Amplifier Gain: x0.5 to x1024X with 0.05% resolution Pre-Filter Gain: x1 to x64 in x2 steps Post-Filter Gain: x0.5 to x16 with 0.05% resolution	Overall Amplifier Gain: x0.25 to x8192 with 0.05% resolution Pre-Filter Gain: x1 to x512 in x2 steps Post-Filter Gain: x0.25 to x16 with 0.05% resolution
Frequency Response	DC to 100 kHz 0 dB ± 0.1 dB; -3 dB at 190 kHz	DC to 200 kHz 0 dB ± 0.1 dB; -3 dB at 500 kHz
Noise	14 nV/ $\sqrt{\text{Hz}}$ at 1 kHz and pre-filter gain >64X typical	7 nV/ $\sqrt{\text{Hz}}$ at 1 kHz and pre-filter gain >64X typical
Offset Drift	10 μ V/ $^{\circ}$ C typical	1 μ V/ $^{\circ}$ C typical
AC Coupling Frequency	0.5 Hz (-3.01 dB)	0.25 Hz (-3.01 dB)
Zero Suppress	Not included in standard model	0.64 V and 10 V Range
Filter Type	LP4FP: 4-pole low-pass filter with programmable maximally flat pass band (Flat Mode) or linear phase (Pulse Mode) responses.	LP4FP (4-pole) and LP8FP (8-pole) low-pass filter with programmable maximally flat-pass band (Flat Mode) or linear phase (Pulse Mode) responses HP4F/LP4FP: 8-pole band pass filter. HP4F Flat Mode 4-pole high-pass filter cascaded with LP4FP 4-pole low-pass filter having programmable maximally flat-pass band (Flat Mode) or linear phase (Pulse Mode) responses.
Filter Cutoff Frequencies	FX01: 100 Hz, 300 Hz, 1 kHz, 3 kHz, 10 kHz, Bypass FX02: 300 Hz, 1 kHz, 3 kHz, 10 kHz, 30 kHz, Bypass	Flat Mode: 2 Hz to 2.046 kHz in 2 Hz steps 2.2 kHz to 204.6 kHz in 200 Hz steps and Bypass Pulse Mode: 1 Hz to 1.023 kHz in 1Hz steps 1.1 kHz to 102.3 kHz in 100 Hz steps and Bypass

PF-1U-7FA HP4F/LP4FP-Z Band-pass Filter Channel Block Diagram

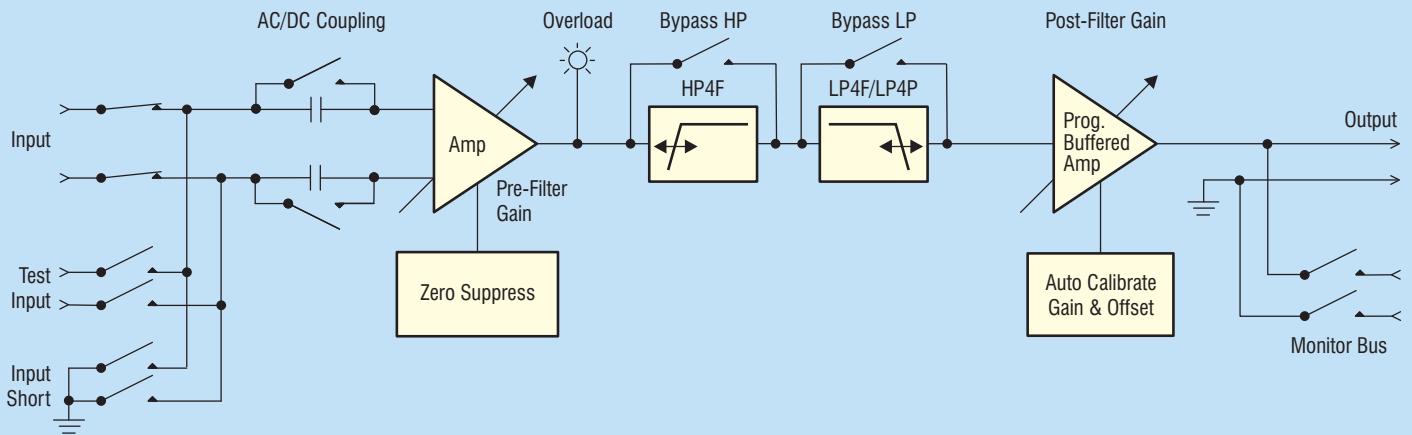

PF-1U-16FA System Block Diagram

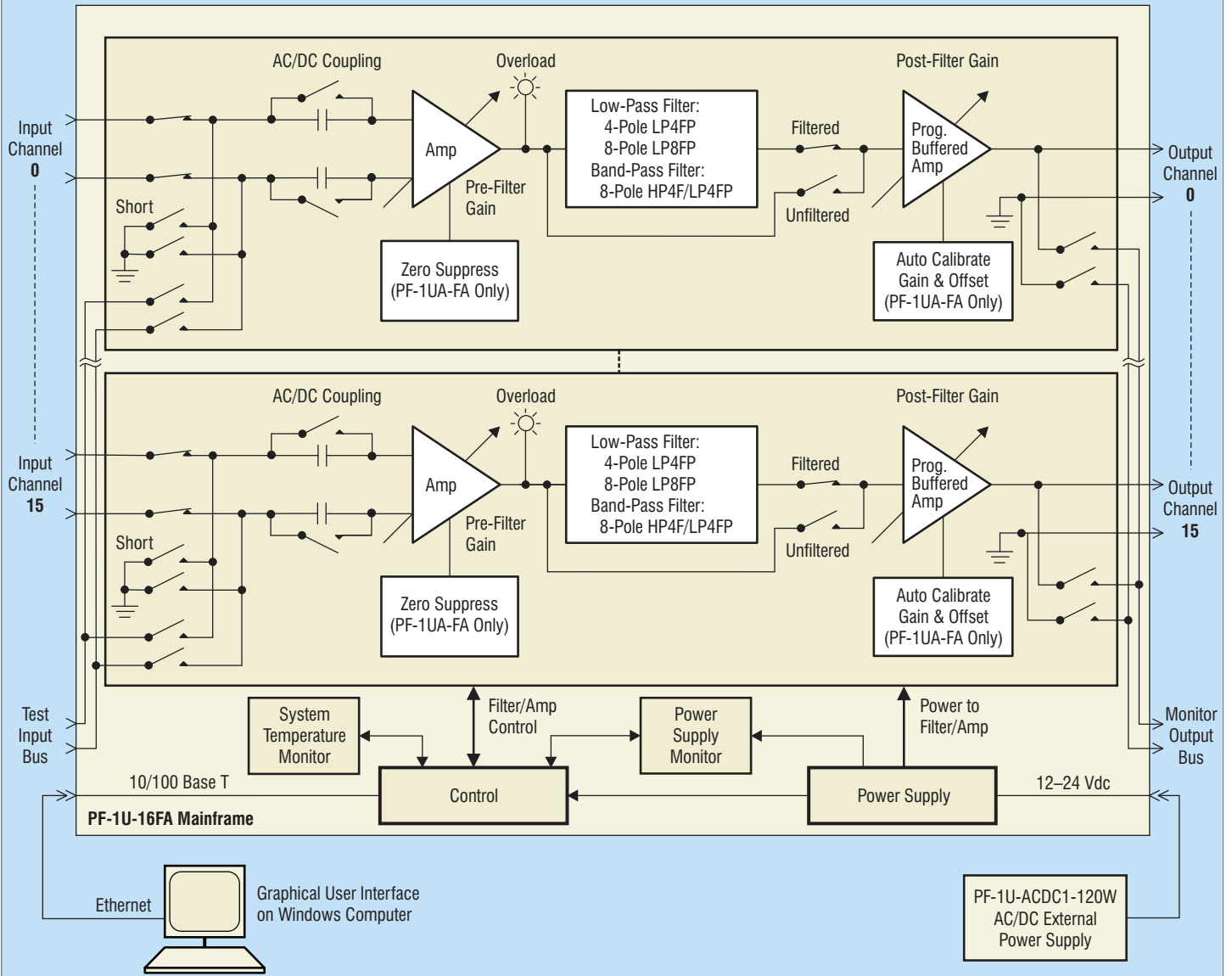

PF-1U-FA Details and Specifications

PF-1U-FA General Characteristics

PF-1U-8FA 8-Channel Filter/Amplifier

Size :
19" x 19" x 1U (1.75") WDH

Weight:
10 lb. 2 oz. (with rack mount)

PF-1U-16FA 16-Channel Filter/Amplifier

Size :
19" x 19" x 1U (1.75") WDH

Weight:
11 lb. 6 oz. (with rack mount)

Operating Temp:
0 to 40°C

Storage Temp:
-25 to 85°C

Power Supply

Input:
12 VDC provided by supplied external 120W AC/DC power supply or 12 to 24 VDC from user supplied DC voltage source

Power Consumption:
75 W, typical

PF-1U-FA External Supply

Model Number:
PF-1U-ACDC2-120W CE/UL Mark

Weight:
2 lb. 8 oz.

Input Power:
110 to 240 VAC, 47-63 Hz

Accessories

Mounting

1U-RM 19-inch Rack Mount Kit:
Rack Mount Kit provides standard 1U height RETMA rack installation (included with system)

PF-1U Rubber Feet Kit:
The PF-1U Rubber Feet Kit provides non-skid feet for desk or table top installation (included with system)

External Power Supply

PF-1U-ACDC2-120W:
AC to DC external 120W power supply 110 to 240 VAC, 47-63 Hz with mating connector; CE/UL approved (included with system)

Power Supply Mating Connector

For alternative power sources, a DC mating connector is available.

Power Supply Mating Connector:
Three-pin Combo-D mating connector (Precision Filters P/N A11328G1)

Precision Product Solutions

For over 30 years Precision Filters has been a global provider of instrumentation for test measurements. You can rely on a single source for signal conditioning and switching—a *complete range of instrumentation*—products optimized to work together to provide high performance at reasonable cost.

Precision Products

28000 Analog Signal Conditioning System



The new standard for the world's most discriminating test labs.

The 28000 System makes it easy to manage a test with up to 256 channels of fully programmable transducer conditioning. Choose a mix of bridge, charge, IEPE w/TEDS, voltage (filter/amplifier), strain, thermocouple, RTD/potentiometer, frequency, or other transducers.

464kB High Density Programmable Switch Matrix



Computer controlled analog signal switching replaces tedious manual patch panels.

The 464kB is a reliable solid-state switch matrix system that provides computer-controlled connection between 256 inputs and 256 outputs, all in a single mainframe. Save time and reduce errors on test system setup. Download switch configurations from the host computer over the network. Built-in self-test with fault diagnostics.

PF-1U-FA System Model Numbers

High Performance Model

PF-1UB-??FA-<LP4FP|LP8FP|HP4F/LP4FP>-<Z>

Zero Suppress (Standard)

Filter Specification:
4-pole low-pass (LP4FP)
8-pole low-pass (LP8FP)
8-pole band-pass (HP4F/LP4FP)

8FA 8-Channel Filter/Amplifier
16FA 16-Channel Filter/Amplifier

Standard Model

PF-1UB-??FA-<RANGE>-LP4FP

FX01, FX02 (Filter Cutoff Frequencies)

8FA 8-Channel Filter/Amplifier
16FA 16-Channel Filter/Amplifier