



Precision 28918A 8-Channel CVLD/IEPE Conditioner

The 28918A 8-Channel CVLD/IEPE Conditioner is a member of the Precision 28000 family of signal conditioners. The 28918A provides conditioning for CVLD accelerometers and IEPE (Integrated Electronic Piezoelectric) accelerometers.

The 28918A is a dual mode card operating in either CVLD mode or IEPE Mode. In CVLD Mode, small AC current signals are detected even in the presence of large noise voltage common with cabling in high magnetic field environments. The constant voltage excitation is programmable to 10 or 15 V. A buffered system test bus signal provides compatibility with CVLD sensors equipped with sensor cal input. In IEPE mode, the 28918A is compatible with either floating or grounded sensors with programmable IEPE current up to 12 mA. The 28918A provides an overall amplifier gain up to 1024 and up to 30 kHz filtered or 190 kHz wideband bandwidths.



Overview

28000 Analog Signal Conditioning System

The new standard for the world's most discriminating test labs.



The Precision 28000 signal conditioning system provides all the flexibility you need to manage your test measurements.

The Precision 28000 makes it easy to manage a test, with hundreds of channels and a mix of transducers. Choose charge, IEPE w/TEDS, voltage (filter amplifier), strain, thermocouple, RTD, potentiometer, current, frequency, or other transducers.

The built-in test hardware and software (optional) provide quick Go/No-Go tests, which can be run before each test, and rigorous Factory Acceptance Tests to assure you that the 28000 meets your most stringent requirements for critical applications. It won't be long before these tests earn a permanent place in your maintenance routine. And since they are traceable to NIST, they eliminate the need for off-site calibration.

In every phase of your tests—record keeping, installation, design, setup, operation, maintenance, and upgrading—the Precision 28000 offers ways to help you save time and money over the life of the system.

28000 System Features

- Graphical user interface (GUI) and Ethernet network interface for system control
- Intelligent gain and system scaling algorithms
- Test input and output monitor busses
- Go/No-Go test with diagnostics to be used before tests
- Rigorous Factory Acceptance Test for maintenance
- Field-swappable AC power supplies
- Built-in temperature and power supply monitoring with alarms

28918A

Applications

- Vibration Measurements in high magnetic noise environments
- Platform noise
- Structure-borne noise
- Acoustic receivers
- Load, torque, dynamic force, dynamic pressure, shock, vibration and acoustic measurements
- Machine health monitoring
- Structural response tests

Precision 28918A Features

- Eight channels per card
- 128 channels per 28016-M3 or 28016-M5 mainframe, 64 channels per 28008-M3/M5 mainframe, 32 channels per 28004-M3/M5 mainframe, 16 channels per 28002-M5 mainframe
- IEPE, CVLD or voltage inputs
- Isolated IEPE mode to break cabling ground loops
- Up to 30 kHz "filtered" bandwidth or 190 kHz "wide-band" bandwidth
- Compatible with single-ended Constant Voltage Line Drive (CVLD) sensors with 2-wire (coaxial) connections
- Programmable IEPE current to 0, 4, 8, 12 mA
- Programmable CVLD excitation 10 or 15 V
- Programmable amplifier: $\times 1/2$ to $\times 1024$ with 0.05 x steps
- 4-pole low-pass filters with filter bypass (wide-band)
- 2° phase matching between any channels, 10 Hz to Fc
- 0.2° typical phase match 10 Hz to 30 kHz (unfiltered)
- Overload detection
- Sensor CAL signal for CAL equipped CVLD sensors

Precision 28918A Description

Precision 28918A Description

CVLD Mode

While cable shielding is very effective at reducing electrostatic noise coupling, it does little to prevent noise coupling due to severe magnetic interference. Since magnetically induced noise is modeled as a noise voltage induced into the sensor cable, it is very disruptive to high sensitivity voltage measurement circuits such as the IEPE accelerometer. Special CVLD accelerometers were developed for magnetic environments that present the vibration signal as a variable current rather than variable voltage. If the attached signal conditioner is sensitive to AC current flow and insensitive to voltage signals, then we can exploit the unique characteristic of the CVLD accelerometer to acquire low-level vibration signals even in the presence of large magnetic interference.

The CVLD Mode of the 28918A is compatible with CVLD accelerometers and detects small AC current signals even in the presence of large noise voltage common in high magnetic field environments. Constant voltage excitation is programmable to 10 or 15 V to accommodate various CVLD sensor models.

Some CVLD sensors have a third wire test signal input that is used to inject a test signal into the CVLD sensor for full end-to-end system checkout. The 28918A is compatible with these sensors and provides a buffered version of the system test bus signal. This signal can be placed individually on each channel or simultaneously on all system channels.

The CVLD sensor has internal electronics, which convert the piezoelectric vibration signal to an output loop drive current. A sudden change of bias current to these internal circuits is a good predictor of sensor malfunction, and could indicate that the sensor should be taken out of service. In CVLD mode, the 28918A continually monitors excitation voltage and bias current into the CVLD sensor. These two parameters are combined together and presented to the user as a single value representing health of the sensor as described by $EXC+Bias = EXC+I(bias) * 400$.

An example of a typical EXC+Bias reading for a CVLD sensor is shown below.

Excitation setting = 15V
Bias Current = 10mA
 $EXC+Bias = 15+10mA * 400 = 19V$

In addition to a visual readout of the EXC+Bias value, user programmed upper and lower fault limits can trigger a gage fault indicator which is clearly visible on the GUI and readable by host software communicating via LCS.

IEPE Mode

In IEPE mode, the 28918A accommodates long cable runs with programmable IEPE current up to 12 mA. Isolated inputs break cabling ground loops associated with triaxial accelerometer or grounded accelerometer cases. Visibility of the DC bias level is a crucial aspect of IEPE sensors as the sensors bias voltage is a useful indicator of sensor, cable and connector health. The 28918A card IEPE input stage continually monitors the DC bias voltage present on the channel input. This voltage level is displayed for each channel and is compared to user programmable upper and lower threshold limits to alert the user to a sudden shift of the bias level. A system bias level report can be requested at any time, creating a file for pre-test gage health documentation.

Amplifier and Filter

Programmable pre- and post-filter amplifiers provide an overall gain of 1024. Gain is distributed both before and after the filter to provide protection from large out-of-band energy or transients that could cause clipping before the filter, distorting the data. The Gain Wizard in the GUI allows the user to set a gain reserve and then apportions the gain between the input and output. This provides input gain for best noise performance yet conforms to the limitations of the user's worst case estimate of out-band or transient signals. Overload detectors alert the user to over-voltage conditions.

The 28918A contains a 4-pole low-pass filter with cutoffs settings of 300 Hz, 1 kHz, 3 kHz, 10 kHz, and 30 kHz and programmable "flat" or "pulse" mode. The "flat" mode provides pass-band characteristics nearly identical to a Butterworth filter while providing a much sharper roll-off. This mode is a good choice for applications such as spectral analysis. The "pulse" mode has time domain response similar to the Bessel filter yet provides superior amplitude response characteristics. The "pulse" mode is ideal for time domain applications including transient (shock) measurements and time domain waveform analysis.

External Pre-Amp Power:

For applications utilizing low noise acoustic sensors with remote pre-amplifiers, the 28918A has built in regulator circuits that provide power to remote pre-amplifiers. Pre-amp output signal can be connected to 28918A high impedance inputs with 28918A in Filter/Amp mode. Up to 20 mA of regulated and fused pre-amp power is available for each channel on the 28918A input connector. +15 V pre-amp power is provided on the standard 28918A model, however other voltages between +26 and -15 V can be specified on as a custom model.

28918A Details and Specifications

28918A Conditioner Cards

The detailed description and specifications for the 28918A are organized in the following sections:

- Programmable Features
- Input Characteristics
- Filter/Amplifier Mode input Characteristics
- Amplifier Characteristics
- Filter Type Characteristics
- Test Modes
- Output Characteristics
- General Characteristics
- Connectors
- Accessories
- Ordering Information

28918A Programmable Features

CVLD Mode

- Sensor power: Programmable to 0, 10 or 15 V
- Sensor calibration (on or off)
- Sensor power monitor with programmable fault limits (upper and lower limits)
- CVLD substitution current (On/Off)

IEPE Mode

- IEPE current (0, 4, 8, 12 mA)
- Bias monitor with programmable fault limits (upper limit and lower limit)
- Input mode (IEPE conditioner or differential input filter/amp)
- AC current dither
- Isolated (sensor grounded) or grounded (sensor isolated)

IEPE/CVLD Common Features

- Gain ($\frac{1}{2}X$ to 1024X)
- Cutoff frequency: (300 Hz, 1 kHz, 3 kHz, 10 kHz, and 30 kHz)
- Wide band 190 kHz (filter bypassed)
- Test modes: run (operate), input short, cal voltage substitution (Test Bus)

Input Characteristics

IEPE Inputs (IEPE Mode)

Type:

Programmable grounded (sensor floating) or isolated (sensor grounded)

Connector:

High, low and shield per channel on high-density 26-pin connector

IEPE Current:

0, 4, 8, 12 mA or disconnect

Current Accuracy:

$\pm 1\%$

Maximum Input:

22 V (DC bias + AC signal)

IEPE Current Noise:

130 pA/ $\sqrt{\text{Hz}}$

Frequency Response (Filter Bypass):

1.17 Hz to 190 kHz

Amplifier Noise:

15 nV/ $\sqrt{\text{Hz}}$ RTI at 1 kHz and pre-gain $\times 16$

CVLD Mode

Type:

Single-ended. Input low connected to system ground.

Connector:

High, low, cal and shield per channel on high-density 26-pin connector

Sensor Excitation:

Programmable 0, 10 or 15 V

Sensor Excitation Accuracy:

5%

Maximum Input:

22 mA (bias + signal current)

Input Sensitivity:

400 mV/mA

Frequency Response (Filter Bypass):

1.17 Hz to 190 kHz

Current Conversion Accuracy:

0.2% (Vout/lin), typical

Sensor Calibration:

Test signal for CVLD sensors equipped with sensor cal input

Sensor Cal On:

Buffered test bus signal applied to sensor cal connection

Sensor Cal Off:

Sensor cal connector biased to –sensor power

Accuracy:

0.2% (10 Hz to 10 kHz)

Noise:

50 pA/ $\sqrt{\text{Hz}}$ @ 1kHz

Line Voltage Rejection:

–80 dB DC to 1 kHz

–60 dB to 10 kHz

CVLD Substitution:

CVLD sensor disconnected, internal CKTS inject CVLD simulation test current to CVLD input stage

Level:

0.5 mA per 1 V test bus signal

Accuracy:

0.2% (10 Hz to 10 kHz)

28918A Details and Specifications

Filter/Amplifier Mode Input Characteristics

Note: Specs at 25°C unless otherwise noted.

Common Mode V:

±10 V operating

CMRR:

-80 dB DC to 1 kHz

Input Protection:

±30 V

Input Impedance:

(0.1 μF & 5 MΩ)/100 pF per side

AC Coupling Frequency:

1.17 Hz (-3 dB)

Max Level:

±10 Vpk for $f \leq 100$ kHz;
±10 Vpk (100 kHz/f) for $f > 100$ kHz

Noise:

15 nV/√Hz RTI at 1 kHz and pre-gain
>x8 typical

Pre-Amp Power Current:

+20 ma max per channel

Pre-Amp Power Accuracy:

±2%

Pre-Amp Power Spectral Noise:

2.5 μV/RtHz

28918A Amplifier Characteristics

Pre-filter Gain:

x1 to x64 in binary steps with overload detection (10.5 Vpk threshold)

Post-filter Gain:

x½ to 16 in 0.05% of setting

Overall Gain:

x½ to x1024 vernier adjustment of 0.05% of setting

Distortion:

0.1% re Fullscale

Frequency Response (Bypass Mode):

-3.01 dB Bandwidth, 1 Hz to 190 kHz, typical

5% Bandwidth: 3.5 Hz to 130 kHz

1% Bandwidth: 8 Hz to 100 kHz

Bypass (Unfiltered) High Frequency Rolloff:

18 dB/octave

28918A Channel Block Diagram

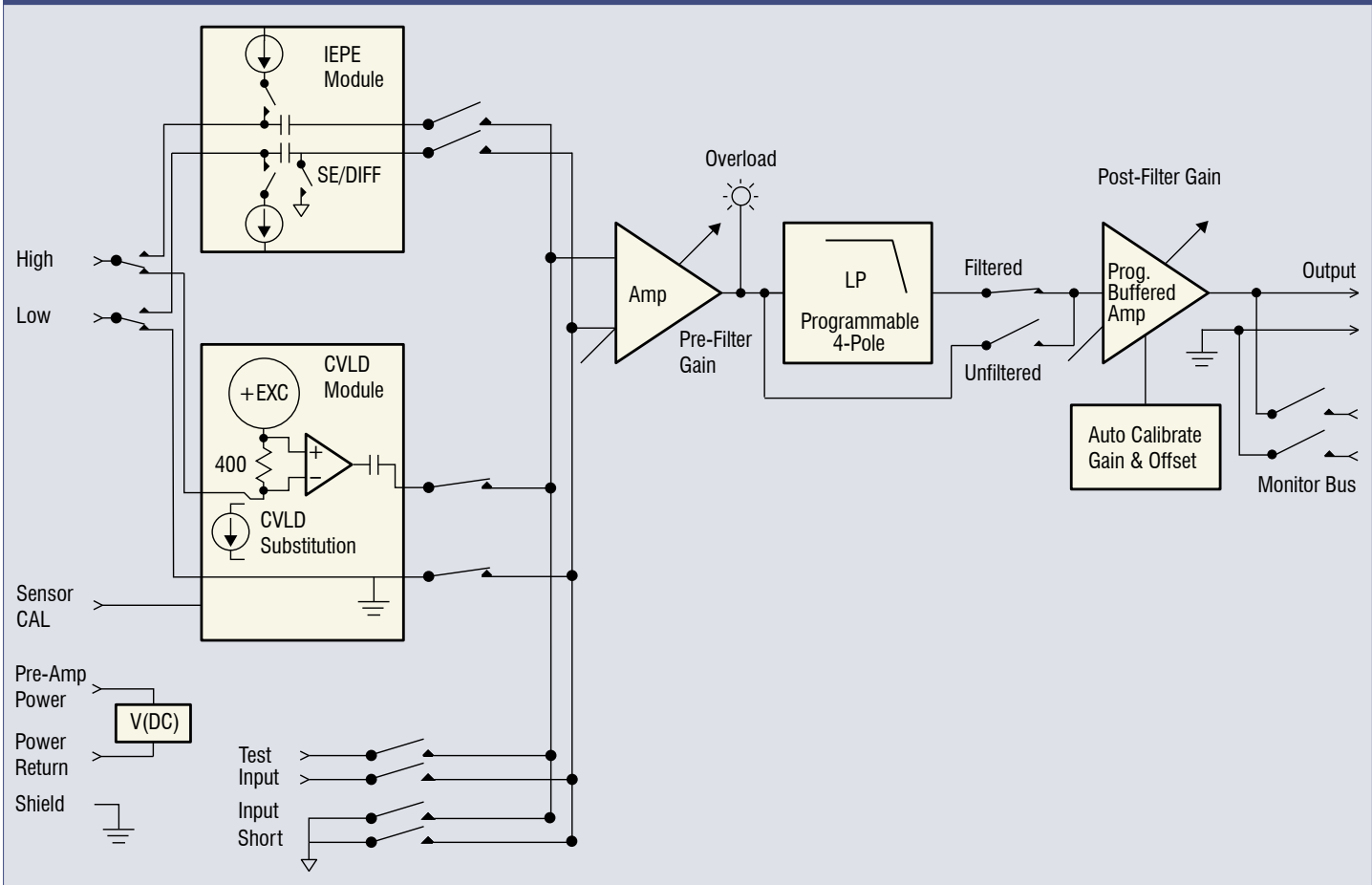

28918A Channel Simplified Block Diagram

28918A Filter Characteristics

You want your analog data to come clean before digital conversion.

Flat/Pulse Low-Pass Filters

Our LP4FP 4-pole flat/pulse low-pass filters provide the user with the versatility to address applications in either the time or frequency domain and are available on many 28000 card models.

Flat Mode Low-Pass Filters

Precision LP4F "flat" mode characteristics are specified to have outstanding passband flatness equivalent to the Butterworth yet deliver very sharp roll-off characteristics.

The LP4F is a good choice as an anti-aliasing filter and for applications such as spectral analysis. The LP4F has zero passband ripple and roll-off superior to the Butterworth.

Pulse Mode Low-Pass Filters

For the time domain, program the 28618 low-pass filter to "pulse" mode. These filters have excellent transient response and phase linearity making them ideal filters for time domain applications including transient (shock) measurements and time domain waveform analysis ... all with roll-off characteristics superior to their Bessel filter counterparts.

LP4F and LP4P Amplitude Response

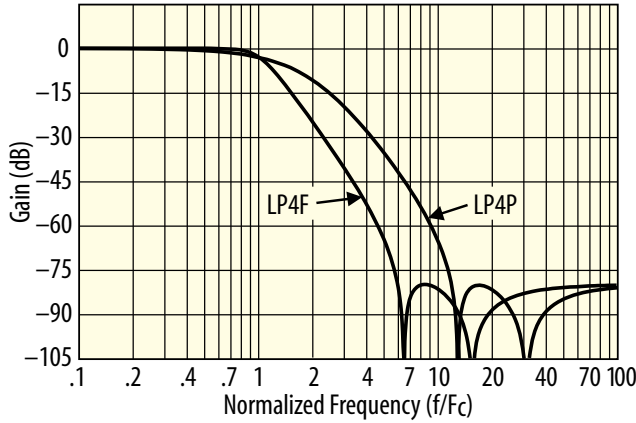

LP4F vs Butterworth Passband Response

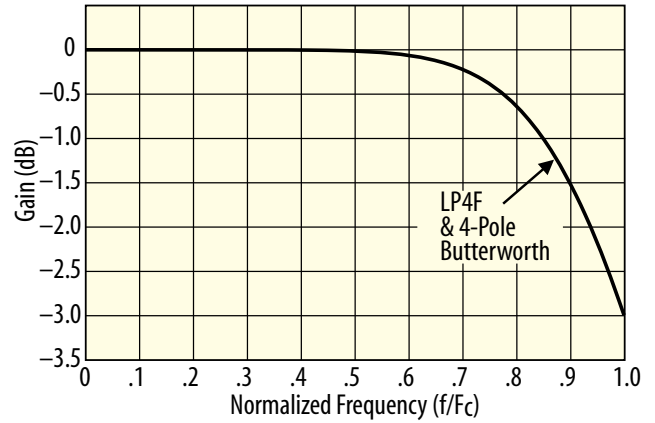

LP4F vs Butterworth Amplitude Response

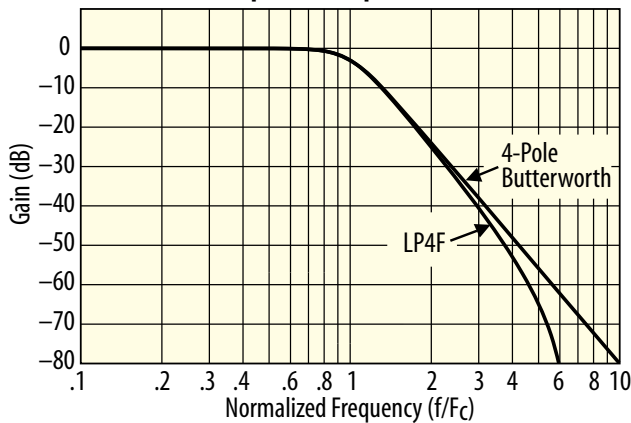

LP4P vs Bessel Passband Response

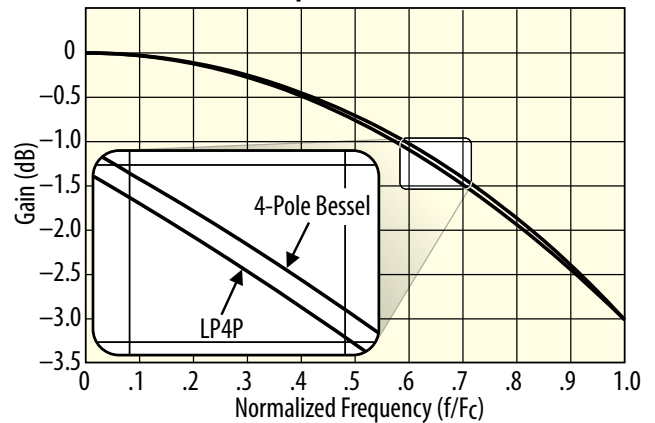

LP4P vs Bessel Step Response

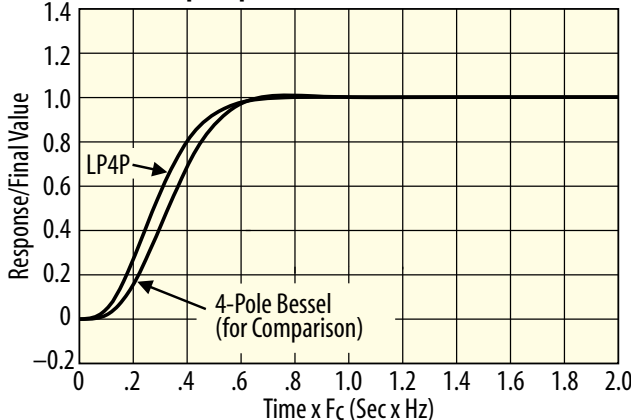

LP4F and LP4P Step Response

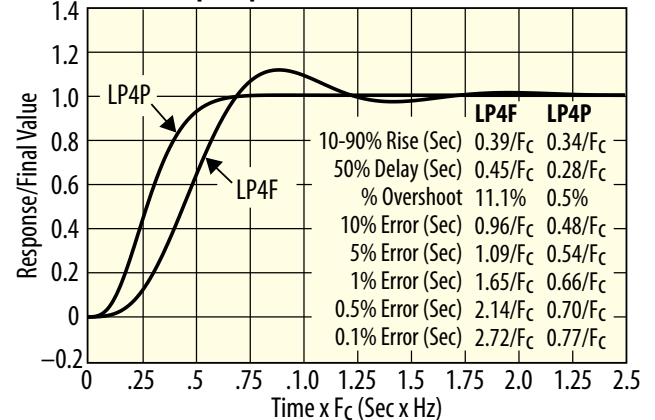

28918A Filter Characteristics

28918A Filter Type Characteristics

Filter Type:

LP4FP: 4-pole, 4-zero low-pass filter.
Programmable for maximally flat pass-band (LP4F) or linear phase with optimized pulse response (LP4P).

Cutoff Frequencies:

FX02:

300 Hz, 1 kHz, 3 kHz, 10 kHz, 30 kHz

Amplitude Accuracy:

±0.1 dB max, DC to 0.8 Fc
±0.2 dB max, 0.8 Fc to Fc

Amplitude Match:

±0.1 dB max, DC to 0.8 Fc
±0.2 dB max, 0.8 Fc to Fc

Phase Match:

±1° max, DC to 0.8 Fc
±2° max, 0.8 Fc to Fc

Filter Bypass:

Bypasses filter but not amplifier stages.
Bypass Bandwidth: 190 kHz, typical

Custom Filters:

Other filter characteristics and cutoff frequencies are available. Please consult with factory for more information.

Specification	LP4F Maximally Flat Low-Pass Filter	LP4P Constant Time Delay Low-Pass Filter
Cutoff Frequency Amplitude	-3.01 dB	-3.01 dB
DC Gain	0.00 dB	0.00 dB
Pass-Band Ripple	0.00 dB	0.00 dB
Stop-Band Frequency (-80 dB)	5.9465 Fc	11.863 Fc
Cutoff Frequency Phase	-180.0 deg	-101.5 deg
Phase Distortion (DC to Fc)	< 31.8 deg	< 3.7 deg
Zero Frequency Group Delay	0.4117/Fc	0.2920/Fc
Percent Overshoot	11.1%	0.5%
1% Settling Time	1.65/Fc	0.66/Fc
0.1% Settling Time	2.72/Fc	0.77/Fc
-0.1 dB Frequency	0.6348 Fc	0.1816 Fc
-1 dB Frequency	0.8487 Fc	0.5742 Fc
-2 dB Frequency	0.9370 Fc	0.8129 Fc
-3.01 dB Frequency	1.0000 Fc	1.0000 Fc
-20 dB Frequency	1.7412 Fc	3.0248 Fc
-40 dB Frequency	2.9555 Fc	5.6932 Fc
-60 dB Frequency	4.5986 Fc	9.0980 Fc
-80 dB Frequency	5.9465 Fc	11.8629 Fc

28918A Details and Specifications

28918A Test Modes

Sensor Cal:

(CVLD Mode only) Test Bus signal is applied to test output line. A buffered (per channel) version of the cal signal is output through the input connector via a separate wire to be used with transducers with a calibration input.

Amplifier Short:

A switch at the amplifier input is utilized to ground the input stage for measurement of noise and DC offset.

CVLD Substitution (CVLD Mode only):

CVLD sensor is disconnected, internal circuits inject simulation current into CVLD input stage

Test Bus:

Test input allows for injection of a test signal. An external test signal or the 28000-?-TEST Test Subsystem may be connected at the rear panel. Refer to the 28000-?-TEST Test Subsystem specification for more information.

AC Current:

(IEPE Mode only) An AC dither current is summed with the IEPE current to create an AC voltage signal based on the transducer's output impedance. AC current is derived from test bus voltage according to:

$$AC\ Current = V\ (Test\ Bus) / 10000$$

28918A Output Characteristics

Type:

Two independently buffered single ended outputs

Z: 10 Ω shunted by 100 pF

Max Output:

±10 Vpk, ±5 mA pk

Noise:

6 μVrms RTI + 60 μVrms RTO, typical
3 Hz to 100 kHz

Crosstalk:

-80 dB, DC to 25 kHz between channels with the same configuration and programmed settings

Output Monitor (Standard)

A switch located at the output of each channel allows for multiplexed connection to the mainframe output monitor bus. The output monitor bus is available at a connector located at the rear of the mainframe. The monitor function is used by the Test Subsystem or is available to the user for viewing channel output.

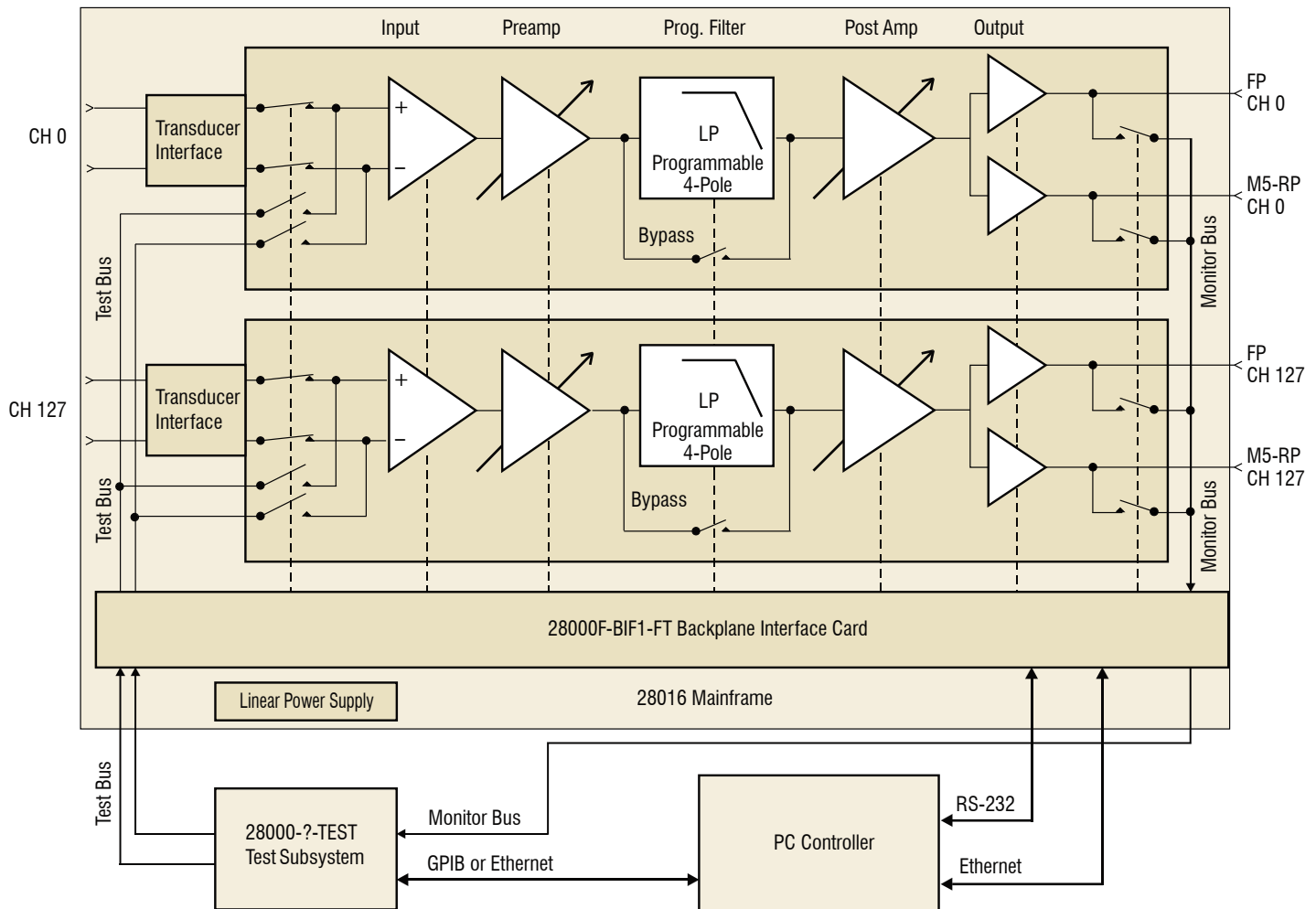

General Characteristics

28918A Card Size:

6.63 x 17.5 x 0.75 inches

Card Weight:

1.4 lb. net

Temperature:

0 °C to 40 °C (operating);
-20 °C to 70 °C (storage)

Connectors

The input connectors are integral to the 28918A card. Cutouts on the 28000 frames allow the 28918A input to pass through the backplane and mate directly with the input cables. Three 26-pin high-density D I/O connectors are utilized, two for the 8 inputs on the rear panel and one for the 8 outputs on the front panel of the card. Connectors have high quality machined gold plated pins/sockets. Three wires per output are provided to accommodate twisted/shielded cables.

Accessories

Mating Connectors

Precision Filters mating connectors accommodate up to 22-AWG wire and are supplied with high-quality metal backshells and gold plated screw machined contacts for high reliability connections and long service life.

CONN-IN-26D High-density 26-pin D-shell mating input connector with machined crimp pins and metal backshell with strain relief.

CONN-IN-26D-SC High-density 26-pin D-shell mating input connector with machined solder cup pins and metal backshell with strain relief.

CONN-OUT-26D High-density 26-pin D-shell mating output connector with machined crimp pins and metal backshell with strain relief.

CONN-OUT-26D-SC High-density 26-pin D-shell mating output connector with machined solder cup pins and metal backshell with strain relief.

Test Adapter and Test Cables:

CB-28908/28918A-TEST-ADAPTER: Input test adapter module for Factory Acceptance Test (FAT).

CB-REF-C: Reference cable for FAT match tests on M3 chassis.

CB-HD26P-REF-C: Reference cable for FAT match tests on M5 chassis.

Precision PF-1U-FA Multi-Channel Programmable Filter/Amplifier System



Exceptional desktop performance.

Ideal for conditioning low-level voltage inputs in front of high-resolution digital data acquisition systems. Fully programmable 8-channel and 16-channel configurations are available, both offering a choice of either 4 or 8-pole low-pass filters with programmable gain.

High Density Programmable Switch Systems

Computer controlled analog signal switching replaces tedious manual patch panels.



Precision 4164 64x64 Switch Matrix System



Precision 464kC Switch Matrix System

Precision switch systems are reliable solid-state switch matrix systems, providing computer-controlled connection between input and output signals. Configure the 464kC with up to 256 inputs and 256 outputs, all in a single mainframe, or choose the compact 4164 system with 64 inputs and 64 outputs. Save time and reduce errors on test system setup. Download switch configurations from the host computer over the network. Built-in self-test with fault diagnostics.

28918A Card Model Number

The 28918A card model number describes the configuration of the eight channels on the card. The model number identifies the filter type of the low-pass and cutoff frequencies.

28918A-<Cutoff Frequencies>-LP4FP <VP?|VN?>

FX02: 300 Hz, 1 kHz, 3 kHz, 10 kHz, 30 kHz

Pre-Amp Voltage Level: -15 V to +26 V
Pre-Amp Voltage Polarity: N = Negative, P = Positive
VP15 Standard