



Precision 28124-EA Quad-Channel Transducer Conditioner with Voltage and Current Excitation and 0.01% DC Accuracy

28124-EA Quad-Channel Transducer Conditioner with Voltage and Current Excitation offers four channels of conditioning to support a wide variety of transducers including those that require constant voltage excitation or constant current excitation. Balanced constant voltage excitation in a bridge configuration supports applications such as strain gages and pressure transducers. The enhanced DC accuracy of the 28124-EA makes it ideal for conditioning load cells, wind tunnels balances, and other precision transducers. Each of three independent outputs can be programmed for filtered or wideband operation, allowing for simultaneous measurement of static and dynamic signals from one transducer.



28124-EA Applications

- Precision load cell conditioner
- Wind tunnel balance
- MEMS pressure sensor (Kulite) conditioner
- Piezoresistive accelerometer conditioner
- Static or dynamic strain measurements
- Full-bridge pressure sensor amplifier
- 2, 3 or 4-wire RTD measurements
- Hot-wire and hot-film anemometry
- Precision AC or DC filter/amplifier (<1 mV to 10 V inputs)

Precision 28124-EA Features

- Four channels per card, 64 channels per 28016 chassis
- Three independent programmable wideband or filtered outputs with output ground sense to reference output to a distant grounded load
- Balanced programmable constant voltage excitation with remote sense – up to 20 V delivered to the bridge with AC shunt calibration test mode for verifying transducer, cabling and measurement system frequency response
- 0.01% enhanced DC accuracy for gain and excitation at specified settings
- Balanced differential constant current excitation (20 mA/20 V compliance) with AC current test mode for verifying transducer, cabling and frequency response
- On-the-fly report of measured transducer excitation and resistance
- Transducer open/short indication
- Transducer leakage resistance measurement in constant current excitation mode
- Automatic bridge balance/transducer suppress
- Up to 51 kHz “filtered” bandwidth or 250 kHz “wide-band” bandwidth
- 2 to 10-wire plus shield bridge input interface
- 2 or 4-wire input plus shield transducer interface with constant current excitation
- Programmable AC/DC input coupling
- Programmable gain: x1/16 to x8192 with 0.003% resolution
- 8-pole low-pass filters with programmable pulse/flat characteristics
- Overload detection
- Precise digital calibration
- Programmable shunt calibration: 5000 step voltage insertion (BC6), 500 step precision resistive (BC12), single-step precision resistive (BC7)
- Programmable bridge configuration: 1-arm, 2-arm or 4-arm bridges
- Programmable bridge resistance: 120 Ω 350 Ω or 1 kΩ

Precision 28124-EA for the 28000 Analog Signal Conditioner

Overview

28000 Analog Signal Conditioning System

The Precision 28000 Signal Conditioning System provides all the flexibility you need to manage your test measurements.



The Precision 28000 makes it easy to manage a test with hundreds of channels and a mix of transducers. Choose charge, IEPE w/TEDS, voltage (filter amplifier), strain, thermocouple, RTD, potentiometer, current, frequency, or other transducers.

The built-in test hardware and software (optional) provide quick go/no-go tests which can be run before each test, and rigorous factory acceptance tests to assure you that the 28000 meets your most stringent requirements for critical applications. It won't be long before these tests earn a permanent place in your maintenance routine. And since they are traceable to NIST, they eliminate the need for off-site calibration.

In every phase of your tests—record keeping, installation, design, set-up, operation, maintenance and upgrading—the Precision 28000 offers ways to help you save time and money over the life of the system.

28000 System Features

- Graphical User Interface (GUI) and Ethernet network interface for system control
- Intelligent gain and system scaling algorithms
- Test input and output monitor busses
- Go/no-go test with diagnostics to be used before tests
- Rigorous factory acceptance test for maintenance
- Field swappable AC power supplies
- Built-in temperature and power supply monitoring with alarms

Precision 28124-EA Description

Precision 28124-EA Description

The 28124-EA is a member of the Precision 28000 family of signal conditioners. The 28124-EA provides four channels of conditioning for transducers requiring constant current or constant voltage excitation. Up to sixteen 28124-EA cards may reside in the 28000 system to provide 64 channels per chassis. In addition, the 28124-EA may be mixed with other conditioners in the 28000 family to meet your unique signal conditioning requirements.

The 28124-EA delivers high DC accuracy for the gain and excitation circuits. The DC gain and excitation are calibrated for better than 0.01% accuracy at specified settings making this amplifier suitable for precision DC measurements required for load cells and wind tunnel balances.

Large changes in sensor impedance or sensor excitation can indicate that data from this sensor is no longer meaningful. The unique transducer health monitor circuits of the 28124-EA provide an "on-the-fly" report of measured sensor excitation and resistance. Measured gage resistance is compared to user specified limits and flagged if out of tolerance. Also, the 28124-EA alerts the user to a transducer open or short condition. The input overload detector reports overloads by out-of-band signals which could cause in-band distortion.

The 28124-EA features precise, automatic calibration of gain and offset for the entire channel, including the amplifier, filter, and excitation supply. Programmable bridge configuration and shunt calibration are supported on all four channels of the 28124-EA card via the optional BC plug-on module. The BC6 or BC7 modules support programmable bridge configuration for quarter, half or full bridges and programmable completion for 120 Ω , 350 Ω or 1 k Ω bridges. The BC6 provides over 5000 steps of bipolar DC shunt calibration while the BC7 has bipolar single-step precision resistor shunt cal. Dedicated shunt cal lines are provided that allow the user to perform the shunt cal on non-current carrying leads.

Balanced Constant Voltage Excitation

The 28124-EA provides balanced constant voltage excitation of up to 20 volts and conditioning for 1-, 2-, and 4-arm resistive bridges. Voltage excitation is programmable from 0 V (OFF) to 20 V with 5 mV of resolution and is calibrated to better than 0.01% for settings of 5, 10 and 20 Volts.

The 28124-EA features automatic calibration of gain and offset for the entire channel, including the amplifier, filter, and excitation supply. The 2- to 10-wire input connection provides 6 wires for the bridge, 3 wires for DC shunt calibration, 1 wire for the shield, and 1 wire for single-arm bridges. Automatic balance of the bridge is accomplished by inserting a voltage ratiometric with the excitation supply to the amplifier input stage. This balance method provides outstanding stability without loading the bridge. A wide range of unbalanced conditions may be accommodated.

Balanced constant voltage excitation offers a number of advantages over single-ended excitation. It enables a true balanced instrumentation amplifier input for outstanding rejection of high frequency common mode signals. Single-ended voltage excitation to balanced bridges produces a relatively large common mode voltage at half the excitation supply. The instrumentation amplifier must reject this signal. Balanced voltage excitation applied to balanced bridges results in lower common mode input voltages to the amplifier input stage.

The excitation supply has automatic amplitude and offset correction that may be run on the unit in place at any time. Dedicated remote sense lines allow the excitation supply regulator to deliver an accurate voltage to the bridge.

The 28124-EA provides a unique AC shunt calibration capability that allows the operator to simulate dynamic gage fluctuations on the bridge. The test bus voltage is utilized as the reference for the AC shunt calibration signal meaning the waveform type and amplitude may be uniquely defined to match waveforms expected during the actual test. In addition to verification of bridge impedance, the AC shunt calibration allows the user to examine the effects of the input cabling on the frequency response of the system.

Balanced Constant Current™ Excitation

The 28124-EA is equipped with Precision Filters' proprietary balanced differential constant current excitation that is optimized for making dynamic strain measurements on single active strain gages. Balanced constant current excitation provides an accurate means of measuring dynamic strain with a single active strain gage using only a two-wire connection. Electrostatic pickup is reduced when compared to single-ended constant current excitation or a quarter bridge configuration with remote completion resistors or unbalanced current sources. The balanced current excitation circuit operates properly even under certain common gage fault conditions such as a direct short of the gage to the test model.

Balanced constant current excitation provides a true balanced input for rejection of common-mode signals. Programmable excitation provides 0 to ± 20 mA of constant current with an "excitation off" mode to detect input cable noise pickup. Gage open/short detection is also provided.

For dynamic strain conditioning applications, the 28124-EA can provide accurate measurements with only two wires by AC coupling the input. For best AC or DC measurements (required for RTD type transducers), the 28124-EA provides a 4-wire Kelvin connection for remote sense. Constant current excitation may be applied to full bridge applications with the advantage that excitation delivered to the bridge is unaffected by excitation supply lead wire resistance.

Suppression of the gage DC operating point is performed automatically using the zero suppress feature of the 28124-EA. Zero suppress allows the use of more gain to emphasize small gage fluctuations. Zero suppress also provides the user with an accurate means to balance a full bridge.

The excitation current source output may be modulated to allow AC current injection in the loop. The frequency and amplitude of the AC current is user controlled. This allows the user to simulate changes in gage resistance in the loop and provides direct AC input stimulation to the signal conditioner for end-to-end system calibration.

28124-EA Details and Specifications

Input Stage

The 28124-EA input stage provides 120 dB of common-mode rejection and may be either AC or DC coupled. AC coupling is useful for dynamic applications where the DC bias on the transducer, that can limit dynamic range, can be coupled out of the signal. With the input DC coupled, low drift and ultra low noise ($< -163 \text{ dBV}/\sqrt{\text{Hz}}$) is provided by the 28124-EA input stage. The input stage may be shorted under program control to verify signal conditioner channel noise and DC offsets.

A switch at the input stage is provided to connect the amplifier to the 28000 system test bus. The test bus is used to inject signals for performance verification. In addition, both drive and sink current levels may be monitored separately making it possible to detect excitation current leakage conditions in the external current loop.

Amplifier and Filter

Programmable pre- and post-filter amplifiers provide an overall gain of 8192. Gain is distributed both before and after the filter to provide protection from large out-of-band energy or transients that could cause clipping before the filter, distorting the data. The Gain Wizard in the GUI allows the user to set a gain reserve and then apportions the gain between the input and output. This provides input gain for best noise performance yet conforms to the limitations of the user's worst case estimate of out-band or transient signals. Overload detectors alert the user to over-voltage conditions. A fully buffered output having over 25 mA of drive capability may be used to drive long output cable runs.

The 28124-EA is specified with a 8-pole low-pass filter with cutoffs programmable from 1 Hz to 51 kHz and programmable "flat" or "pulse" mode. The "flat" mode provides pass-band characteristics nearly identical to a Butterworth filter while providing a much sharper roll-off. This mode is a good choice for applications such as spectral analysis. The "pulse" mode has time domain response similar to the Bessel filter yet provides superior amplitude response characteristics. The "pulse" mode is ideal for time domain applications including transient (shock) measurements and time domain waveform analysis.

Output Stage

The 28124-EA has three independently buffered outputs. A single-ended rear panel output is intended to drive the primary data acquisition hardware. Two sets of auxiliary outputs are available on the front panel of the card. All three outputs have ground sensing circuitry that breaks ground loops when connecting grounded loads. The sensing circuitry also corrects the output for any potential differences between the 28124-EA ground and the load ground.

Each of the three outputs may be selected for filtered or wideband operation under program control. This allows the 28124-EA to measure both AC (dynamic) and DC (static) signals coming from one transducer.

Verification of Cables and Sensor Health:

Strain Gage Loop Resistance Measurement: Dynamic strain measurements often require complicated wiring schemes. Long cable runs, multiple connection points, high-temperature high-impedance very small diameter wire and slip rings combine to cause uncertainty in the strain gage connection. Often a sudden increase in gage resistance is a predictor of gage failure. The Precision 28124-EA gives continual real time monitoring of the total "Loop Resistance" of the gage and cable circuit. This loop resistance reading can be compared to preset limits to alert the user of unexpected resistance shifts as well as gross gage short and gage open conditions.

Cable Roll-off: One often asked question of many measurements engineers is "How will my cable capacitance affect my high frequency strain measurement"? This question can be answered quickly and easily and all from the convenience of the control room. The AC dither current feature of the 28124-EA, in balanced constant current excitation mode, modulates a small AC current on top of the DC excitation current to stimulate an AC signal across the actual strain gage sensing element. In balanced constant voltage excitation mode, the AC shunt calibration feature allows the operator to inject an AC current into a bridge corner to simulate actual gage fluctuations.

Since the stimulus signal is based at the sensor, it will exhibit the same roll-off characteristics as a signal resulting from actual dynamic strain. The test frequency of the AC signal can be increased as necessary to chart the cable roll-off characteristics and validate the cable circuit for use at the desired measurement frequencies.

Gage Leakage Measurements: In extremely hot sections of a gas turbine engine, it is impossible to use standard insulating materials in gage wiring. Often a rigid section of a stainless steel or Inconel sheath encloses high temperature inner conductor wires. The inner core of the sheath is filled with magnesium oxide (MGO) as a high temperature insulating material. The insulating properties of the MGO are affected by moisture absorption at damage points or improperly sealed cable terminations. In extreme conditions, insulation breakdown can cause a leakage path to ground and corrupt a gage reading. Other causes of cable leakage are fatigue or failure at extension wire tie-down points, or in the strain gage itself. The leakage detection feature of the 28124-EA continually monitors leakage and compares readings to preset threshold limits. Sensors which show higher than normal leakage can be quickly identified prior to or during the test run.

Muting Faulty Sensors:

Depending on the sensor type, various techniques must be used to quiet the channel's input and output circuits and ensure that no noise coupling occurs. For example, an intermittent gage will create a gage chatter condition whereby the connecting wires continually switch between the high voltage fault level and the proper low voltage operational level. This chatter condition creates a hostile noise source to any other gage extension wires in the vicinity of the hostile cable. Precision 28124-EA signal conditioning channels have a "MUTE" feature, which places the channel in its quietest quiescent state and minimizes the possibility of coupling noise to properly functioning channels.

28124-EA Details and Specifications

Programmable Bridge Configuration Modules

Constant Voltage Excitation Mode:

The optional BC plug-on bridge configuration modules provide support for programmable bridge configuration. In addition, the BC6 and BC7 modules support programmable DC shunt calibration for all four channels on the 28124-EA card when using constant voltage excitation. The BC8 module provides conditioning for modulated current output transducers, such as those with 4-20 mA outputs.

All completion modules may be programmed to support 1-arm, 2-arm or 4-arm (quarter, half or full) bridge configurations. Completion resistance is programmable for 120 Ω , 350 Ω or 1 k Ω . Completion resistors are metal foil technology and are very precise and very stable.

The BC6 DC shunt calibration utilizes voltage insertion at the bridge, providing over 5000 steps of single shunt calibration of bridge arms R1 or R2. The user may program the shunt to be applied at the gage (if additional cable wires are used) or at the instrument. Shunt sensitivity is set by a precision resistor on the BC6 card and is programmable from ± 125 mV per V of programmed excitation to ± 8 mV/V in 0.2% resolution. The effective range of shunt resistor values is 30.75 to 2000 times the bridge programmed bridge resistance. The BC6 shunt calibration may only be used in conjunction with constant voltage excitation.

The BC7 provides traditional single-step bipolar shunt cal using a precision resistor. Single shunt of either R1 or R2 bridge arms may be selected. The standard BC7 shunt cal produces 1 mV/V single shunt. Consult factory if custom shunt resistor values are required.

The BC8 supports 2-wire or 4-wire connections to modulated current output devices that require a constant voltage power supply to excite them and provide a current output proportional to the measurement units. This includes sensors with 4-20mA outputs. The BC8 switches a 250 ohm resistor across the amplifier input to measure the sensor current output.

The BC9 completion module supports programmable bridge completion only.

Constant Current Excitation Mode:

When using constant current excitation, the bridge configuration modules provide programmable configuration of 2-wire or 4-wire input mode. 2-wire mode is useful for dynamic strain measurements where the input stage of the amplifier is AC coupled. The 4-wire mode may be used to make static measurements with a Kelvin connection to the gage. The 28124-EA zero suppress circuit can be used to zero the transducer bias when operating in the 4-wire configuration. The wide range of the zero-suppress circuit can accommodate large transducer bias voltages.

Bridge Wiring

Input Connector:

26-pin high-density D-shell (2 ea.)

Input Wires:

\pm EXCITATION (2)
 \pm SENSE (2)
 \pm SIGNAL (2)
SHUNT CAL (3)
¼ Bridge RTN (1) Single Arm Bridge
SHIELD (1)

Bridge Configuration Module Specifications:

Completion Resistors:

120 Ω , 350 Ω and 1 k Ω , programmable

Bridge Configuration:

1-arm, 1-arm w/ 3 wires, 2-arm or 4-arm, (programmable)

Resistor Temperature Coefficient:

± 0.2 ppm / $^{\circ}$ C

Resistor Accuracy: $\pm 0.02\%$

BC6 DC Shunt Calibration (Constant Voltage Excitation Mode Only):

DC Shunt Selection:

R1 or R2 bridge arms

Equivalent Shunt Resistance Settings:

30.75R to 2000R w/ 0.2% minimum resolution where R = 120 Ω , 350 Ω or 1 k Ω

Shunt Sensitivity:

± 0.125 mV/V to ± 0.5 mV/V
in ± 0.25 μ V/V steps
 ± 0.501 mV/V to ± 2.0 mV/V
in ± 1.00 μ V/V steps
 ± 2.004 mV/V to ± 8.0 mV/V
in ± 4.00 μ V/V steps

Shunt Accuracy:

$\pm 0.2\%$ for programmed excitation > 1 V

BC7 DC Shunt Calibration:

DC Shunt Selection:

R1 or R2 bridge arms

Shunt Sensitivity:

± 1 mV per volt of programmed excitation

Shunt Resistance:

29.940 k Ω for 120 Ω bridge
87.325 k Ω for 350 Ω bridge
249.5 k Ω for 1 k Ω bridge

Resistor Accuracy:

$\pm 0.1\%$

BC8 Current Sense:

Modes:

2-wire or 4-wire sense of sensors with 4-20 mA output

Sense Resistor:

250 ohms $\pm 0.1\%$

BC12 DC Shunt Calibration

DC Shunt

Selection: R1 or R2 bridge arms.

Shunt Resistance:

255 values between 7.5 k Ω and 1.92 M Ω . Please contact factory for more detailed information.

Resistor Accuracy: $\pm 0.1\%$

28124-EA Details and Specifications

28124-EA Excitation Supply Programmable Constant Voltage Excitation

Maximum Output:
20.475 V, 30 mA (balanced)

Steps:
Programmable from 0 to 20.475
in 5 mV steps

Excitation Sense:
Programmable (instrument or
gage sense)

Accuracy:
±0.01% for 5, 10 and 20 V settings;
±0.03%, ±500 µV for all other settings.

Noise:
100 µVrms, 3 Hz to 200 kHz

Temperature Drift:
±0.0025%/°C of setting or ±50 µV/°C,
whichever is greater

Sense Leakage Current:
Less than 10 µA

Calibration:
Automatically calibrated for gain and
offset. Calibration initiated at the GUI
panel.

Excitation Off:
The excitation supply is programmed
to 0 volts.

28124-EA Constant Current Excitation Supply

Type:
Balanced differential constant current
excitation

Excitation:
0 to 20.475 mA in 5 µA steps

Total Gage Voltage (Volts):
22 – I × 700 minimum

Input Impedance:
100 kΩ nominal per side

CMRR (DC to 1 kHz):
80 dB for 120 Ω gage
70 dB for 350 Ω gage
60 dB for 1 kΩ gage

Initial Accuracy:
0.05%, 5 µA

Temperature Drift:
30 nA + 0.0024% of setting per °C

Noise:
65 pA/√Hz at 1 kHz

Bandwidth:
±0.2 dB to 200 kHz (RGAGE < 1 kΩ)

28124-EA Programmable Features

- Constant voltage excitation level: 0 to 20.475 V in 5 mV steps
- Constant current excitation level: 0 to 20.475 mA in 5 µA steps
- Expected transducer resistance and tolerance
- Transducer leakage resistance thresholds
- Voltage excitation sense: instrument or gage
- Current excitation input interface: 2-wire or 4-wire
- Bridge configuration: 1-arm (2-wire), 1-arm (3-wire), 2-arm or 4-arm
- Bridge resistance: 120 Ω, 350 Ω or 1 kΩ
- DC shunt cal: instrument or gage
- DC shunt cal resistance and shunt arm: R1 or R2
- Automatic balance/suppress
- AC/DC input coupling
- Test modes: amp short, 10 V DC CAL, excitation off, test bus (voltage substitution), DC shunt calibration, AC shunt calibration, AC current, excitation monitor
- Output monitor
- Gain: x1/16 to x8192 with 0.003% resolution
- Filter type: pulse or flat
- Cutoff frequency: 2 Hz to 25.5 kHz, flat mode
1 Hz to 25.5 kHz, pulse mode
- Wide-band (250 kHz) or filtered operation

28124-EA Graphical User Interface Display

- All programmable features in addition to:
- On-the-fly excitation monitor
- On-the-fly sensor resistance monitor with pass/fail status
- Sensor open or short indication
- Configuration read back
- Balance/Suppress status
- Input wiring
- Transducer sensitivity
- System scaling in engineering units
- Overload status
- Intelligent gain algorithm
- Group control

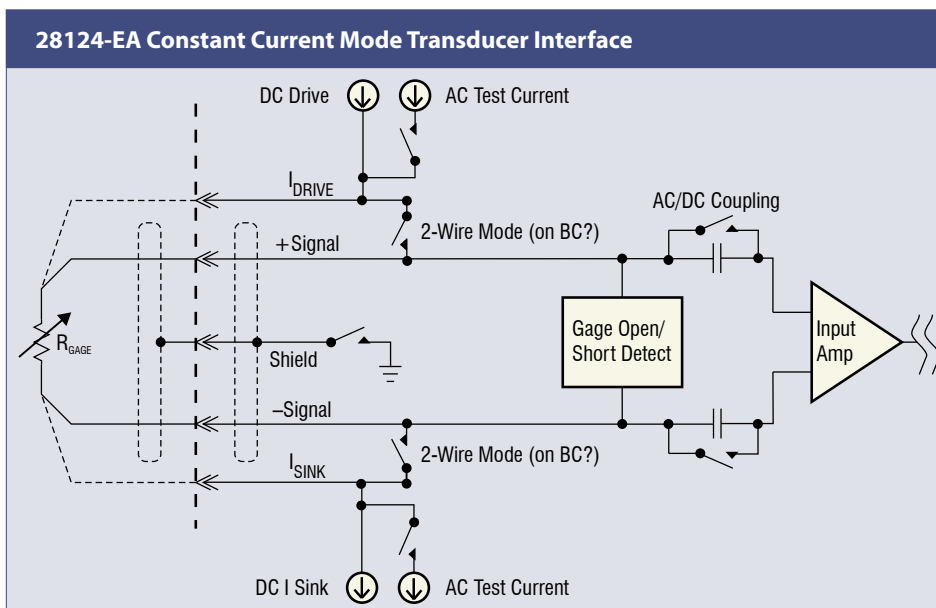

28124-EA Details and Specifications

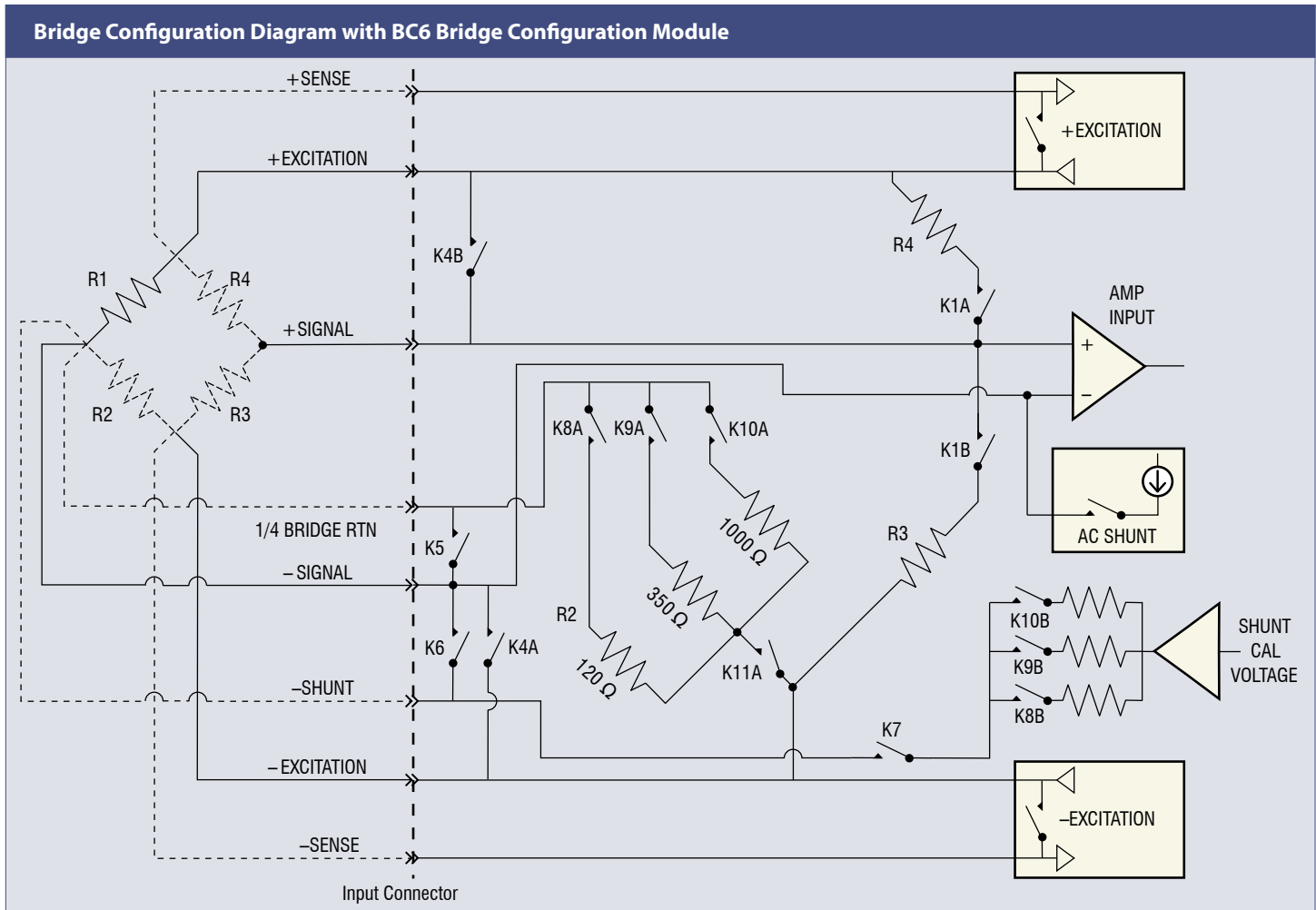

Truth Table

Configuration	K1	K4	K5	K6	K7	K8	K9	K10	K11
¼ Bridge, 2-Wire	IN		IN			IN ¹	IN ¹	IN ¹	IN
¼ Bridge, 3-Wire	IN		OUT			IN ¹	IN ¹	IN ¹	IN
½ Bridge	IN					OUT	OUT	OUT	OUT
Full Bridge	OUT					OUT	OUT	OUT	OUT
120 Ohm Completion						IN	OUT	OUT	IN
350 Ohm Completion						OUT	IN	OUT	IN
1000 Ohm Completion						OUT	OUT	IN	IN
Shunt Cal Gage				OUT	IN				
Shunt Cal Instrument				IN	IN				
Constant Current 2-Wire		IN							
Constant Current 4-Wire		OUT							

¹ One switch selected at a time.

28124-EA Details and Specifications

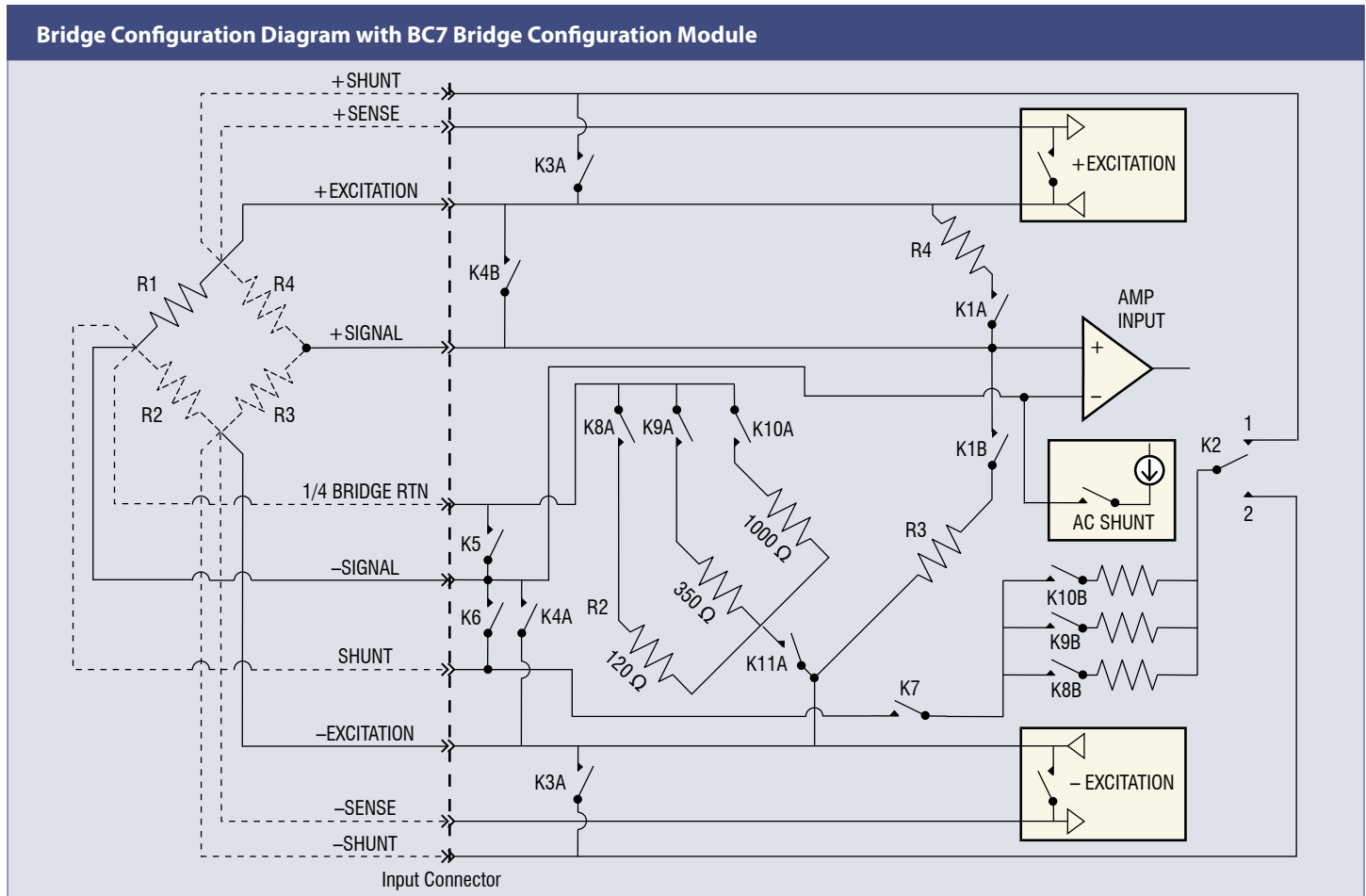

Truth Table

Configuration	K1	K2	K3, K6	K4	K5	K7	K8	K9	K10	K11
¼ Bridge, 2-Wire	IN				IN		IN ¹	IN ¹	IN ¹	IN
¼ Bridge, 3-Wire	IN				OUT		IN ¹	IN ¹	IN ¹	IN
½ Bridge	IN						OUT	OUT	OUT	OUT
Full Bridge	OUT						OUT	OUT	OUT	OUT
120 Ohm Completion							IN	OUT	OUT	IN
350 Ohm Completion							OUT	IN	OUT	IN
1000 Ohm Completion							OUT	OUT	IN	IN
Shunt Cal Gage			OUT			IN				
Shunt Cal Instrument			IN			IN				
Shunt R1		1				IN				
Shunt R2		2				IN				
Constant Current 2-Wire				IN						
Constant Current 4-Wire				OUT						

¹ One switch selected at a time.

28124-EA Details and Specifications

MUTE Mode

In harsh test environments, a sensor or input cable can become faulty or intermittent during a critical test. With high gain signal conditioning this can be troublesome if large signal swings on input or output cabling cross couple to other channels. The 28124-EA Mute control places the channel in the quietest operational state to minimize system noise in the event of a failed sensor. The Mute Mode is also useful to terminate unused channels in a safe and quiet state.

Transducer Health Monitor

Sensor Excitation Monitor: Transducer excitation voltage or current is monitored and reported to the user on-the-fly. Measured excitation is compared to factory set tolerance and GUI indicators report if out of tolerance.

Sensor Resistance Monitor: Transducer resistance is monitored on-the-fly and compared to user defined limits. GUI indicators report if sensor resistance is out of user tolerance.

Sensor Open/Short Monitor: Transducer open or short condition is monitored and reported to the user via GUI indicators.

Transducer Leakage Resistance Measurement: The 28124-EA monitors gage bias levels in order to detect constant current excitation leakage conditions in the external current loop. Transducer leakage status is monitored and reported via the GUI.

Excitation Current Limit: Current limit protection is provided by the 28124-EA excitation supply. Possible causes of current limit are an incorrect excitation setting or a shorted transducer. Current limit indicators are provided in the GUI.

Excitation Thermal Shutdown: The excitation supply regulator die temperature is continuously monitored and will shut down should the temperature reach a level where damage to the excitation supply may occur. Thermal shutdown indicators are provided in the GUI.

Input Characteristics

Type:

Balanced differential w/ programmable AC/DC input coupling

Input Impedance:

10 M Ω //100 pF per side

Max Level (AC + DC + Common Mode):

± 10 Vpk for $f \leq 200$ kHz
 ± 10 Vpk x (200 kHz/f) for $f > 200$ kHz

Input Protection (Power On):

30 V continuous, 100 Vpk for 1mS,
10% duty cycle

Offset Drift:

1 μ V/ $^{\circ}$ C, typical

Noise:

10 nV/ $\sqrt{\text{Hz}}$ at 1 kHz and pre-filter gain
> 64, typical

AC Coupling Frequency:

0.25 Hz (3.01 dB)

CMRR (DC Coupled):

110 dB, DC to 440 Hz and input gain > x16

CMRR (AC Coupled.):

100 dB, 10 Hz to 440 Hz

Auto Bridge Balance Mode:

The bridge is automatically balanced utilizing voltage insertion at the input amplifier when bridge balance mode is selected. The inserted voltage is derived from and thus tracks the excitation supply. A successive approximation A/D converter mechanization is used for rapid bridge balance.

Range:

Bridge balance algorithm selects the most appropriate range to achieve balance with finest resolution.

32 mV/V Mode Auto-Balance Ranges:

± 0.001 mV/V to ± 32 mV/V in
 ± 0.976 μ V/V steps

512 mV/V Mode Auto-Balance Ranges

(Gain limited to x512):

± 0.016 mV/V to ± 512 mV/V in
 ± 15.625 μ V/V steps

Accuracy:

$\pm 0.1\%$ of setting $\pm 0.1\%$ of F.S. range

Stability:

± 25 ppm / $^{\circ}$ C of setting

Drift (RTI):

± 0.3 μ V / $^{\circ}$ C for 32 mV/V range;
 ± 5 μ V / $^{\circ}$ C for 512 mV/V range

Auto Balance Time:

Less than 60 seconds per system of 64 channels.

Auto Suppress Mode:

A programmable DC offset derived from a precision 10 V reference is injected at the channel input stage to suppress the gage DC operating voltage. Manual or automatic suppression modes are supported.

640 mV Suppress Ranges: ± 0.001 mV to

± 640 mV in ± 19.53 μ V steps

10.24 V Suppress Ranges

(Gain limited to x512):

± 0.3125 mV to ± 10.24 V in ± 312.5 μ V steps

Accuracy:

$\pm 0.1\%$ of setting $\pm 0.1\%$ of F.S. range

Stability: ± 25 ppm / $^{\circ}$ C of setting

Drift (RTI): ± 0.3 μ V / $^{\circ}$ C for 640 mV range;

± 5 μ V / $^{\circ}$ C for 10.24 V range

Auto Suppress Time:

Less than 60 seconds per system of 64 channels.

28124-EA Details and Specifications

28124-EA Amplifier Characteristics

Pre-Filter Gain:

x1 to x512 in binary steps with overload detection (10.5 Vpk threshold)

Post-Filter Gain:

x1/16 to x16 in binary steps with vernier adjustment

Overall Gain: x1/16 to x8192

Gain Setability:

0.003% steps for POG $\geq 0.5X$
0.003%/POG for POG $< 0.5X$

DC Gain Accuracy: (to primary rear output):

Gains of x1, 2, 4, ..., 2048: $\pm 0.01\%$ max for RES ≤ 2 and POG ≥ 1

All other gains:
 $\pm 0.02\%$ max for POG ≥ 0.5

DC Gain Accuracy (to AUX 1 and AUX 2 front panel outputs):

Gains of x1, 2, 4, ..., 2048: $\pm 0.02\%$ max

All other gains:
 $\pm 0.03\%$ /POG max for POG ≥ 0.5

Gain Ratio of Wideband (Unfiltered) to the Filtered Outputs:

Each of the three 28124-EA outputs may be selected for wideband or filtered operation under program control. The ratio of the gain on the wideband output to the filtered output may be set from 0.1000 and 1.0000 with 0.1% resolution. All GUI gain wizard calculations will be based on filtered output.

Stability: $\pm 0.01\%$ for 6 months

Temp Coef.: $\pm 0.004\%/^{\circ}C$

DC Linearity:

$\pm 0.005\%$ re Fullscale, relative to the best straight line

Frequency Response:

DC to 100 kHz, 0 dB ± 0.1 dB
-3 dB typical @ 250 kHz

High Frequency Roll-off:

18 dB/octave

28124-EA Test Modes

Amplifier Short: A switch at the amplifier input is utilized to ground the input stage for measurement of noise and DC offset.

Test Bus: Test input allows for injection of a test signal. An external test signal or the 28000-?-TEST Test Subsystem may be connected at the rear panel. Refer to the 28000-?-TEST Test Subsystem specification for more information.

10 VDC CAL: A calibrated 10 VDC reference is connected to the amplifier input. The NIST traceable measured error (in percent) is stored in non-volatile memory on the card. Subsequent NIST traceable field measurement of the 10 VDC reference requires the 28000-4A-TEST test subsystem.

DC Shunt Cal: Applies shunt to bridge.

Excitation Monitor (Constant Voltage Mode Only): The amplifier input is switched from the bridge to the excitation supply to monitor the excitation voltage at the amplifier output. Excitation monitor gain is x0.5.

Excitation Off: The excitation supply is programmed to zero volts or zero mA.

AC Shunt Calibration (Constant Voltage Mode Only): An AC shunt calibration current is injected into the bridge to verify bridge impedance and to evaluate the end-to-end frequency response of the system. The AC shunt reference signal is derived from the voltage on the test bus.

AC Shunt Sensitivity:
10 μ Apk per Vpk of test bus voltage

AC Shunt Current Accuracy

(350 Ohm Bridge):
 $\pm 0.2\%$ at 1 kHz
-5% typical at 50 kHz
-3 dB typical at 160 kHz

AC Current (Constant Current Mode Only):

An AC current is injected into the current loop to evaluate end-to-end system frequency response. The AC current is generated from a voltage waveform on the test bus.

AC Current Sensitivity:
100 μ Apk per Vpk of test bus voltage

AC Shunt Current Accuracy

(350 Ohm Loop Resistance at Input):
 $\pm 0.2\%$ at 1 kHz,
-5% typical at 50 kHz
-3 dB typical at 160 kHz

Precision 28000 Test Subsystem

The 28000 test subsystem supports a suite of tests that run on the instrument right where it is, with no need to disassemble or move it. The tests check out all critical system specifications, are NIST traceable, and are the same manufacturing tests that are run at the factory. The test subsystem is required to perform automated calibration of the 28124-EA DC gain and excitation.

The test subsystem consists of third-party test instruments (PF model 28000-7-TEST) to provide signal sources and precise measurement capability. A Keysight 33509B function generator is used as the source of the test signals, and a 3458A 8 1/2 digit precision multi-meter provides measurement capability of verifying the enhanced DC specifications of the 28124-EA with sufficient Test Uncertainty Ratio (TUR).

In addition, the 28000-7-TEST includes a kit for rack mounting and cables necessary to connect the instruments to the 28000 test and monitor busses.

The 28000 test subsystem provides three levels of test. Pretest Verify and Diagnostics are used to confirm that all elements of the test subsystem are functional. The Factory Acceptance Test (FAT) performs a complete parametric performance check of the signal conditioners. Parameters such as common mode rejection ratio noise, offset, gain, frequency response, amplitude match, and phase match are tested to original specifications. The Go/No-Go test does a quick check of the current programmed setup prior to an actual test to provide documented proof of system performance.

The same host computer controlling the 28000 system is used to control the test subsystem instruments. The GUI running on this computer controls all components necessary to run complete system tests. The 28000 channels are set to a desired test state, appropriate signal sources are selected, levels are programmed, and the multi-meter (DMM) is read—all under computer control. For traceability, the DMM is kept in calibration by a qualified metrology test lab.

28124-EA Details and Specifications

Filter Type Characteristics

Flat/Pulse Low-Pass Filters

Our LP8FP 8-pole flat/pulse low-pass filters provide the user with the versatility to address applications in either the time or frequency domain.

Flat Mode Low-Pass Filters

Precision LP8F "flat" mode characteristics are specified to have outstanding passband flatness equivalent to the Butterworth yet deliver very sharp roll-off characteristics.

The LP8F is a good choice as an anti-aliasing filter and for applications such as spectral analysis. The LP8F has zero passband ripple and roll-off superior to the Butterworth.

Pulse Mode Low-Pass Filters

For the time domain, we offer the LP8P "pulse" mode low-pass filters. These filters have excellent transient response and phase linearity making them ideal filters for time domain applications including transient (shock) measurements and time domain waveform analysis ... all with roll-off characteristics superior to their Bessel filter counterparts.

LP8FP Specifications:

8-pole, 8-zero low-pass filter.

Programmable for maximally flat pass-band (LP8F) or linear phase with optimized pulse response (LP8P).

Note: Other filter types and cutoff ranges available upon request. Please consult factory.

Cutoff Frequencies:

Flat Mode:

2 Hz to 510 Hz in 2 Hz steps
600 Hz to 25.5 kHz in 200 Hz steps

Pulse Mode:

1 Hz to 255 Hz in 1 Hz steps
300 Hz to 25.5 kHz in 100 Hz steps

Amplitude Accuracy:

±0.1 dB max, DC to 0.8 Fc
±0.2 dB max, 0.8 Fc to Fc

Amplitude Match:

±0.1 dB max, DC to 0.8 Fc
±0.2 dB max, 0.8 Fc to Fc

Phase Match:

±1° max, DC to 0.8 Fc
±2° max, 0.8 Fc to Fc

Bypass:

Bypasses filter but not amplifier stages.

Bypass Bandwidth:

250 kHz, typical

Specification	LP8F Maximally Flat Low-Pass Filter	LP8P Constant Time Delay Low-Pass Filter
Cutoff Frequency Amplitude	-3.01 dB	-3.01 dB
DC Gain	0.00 dB	0.00 dB
Pass-Band Ripple	0.00 dB	0.00 dB
Stop-Band Frequency	1.7479 Fc	3.4688 Fc
Cutoff Frequency Phase	-360.0 deg	-161.9 deg
Phase Distortion (DC to Fc)	<102 deg	<0.05 deg
Zero Frequency Group Delay (SEC)	0.7197/Fc	0.4496/Fc
Percent Overshoot	18.9%	1.1%
1% Settling Time	4.03/Fc	1.25/Fc
0.1% Settling Time	7.02/Fc	2.25/Fc
-0.1 dB Frequency	0.8538 Fc	0.180 Fc
-1 dB Frequency	0.9437 Fc	0.5685 Fc
-2 dB Frequency	0.9772 Fc	0.8087 Fc
-3.01 dB Frequency	1.0000 Fc	1.0000 Fc
-20 dB Frequency	1.2149 Fc	2.2342 Fc
-40 dB Frequency	1.4443 Fc	2.7556 Fc
-60 dB Frequency	1.6391 Fc	3.2016 Fc
-80 dB Frequency	1.7479 Fc	3.4688 Fc

LP8F and LP8P Amplitude Response

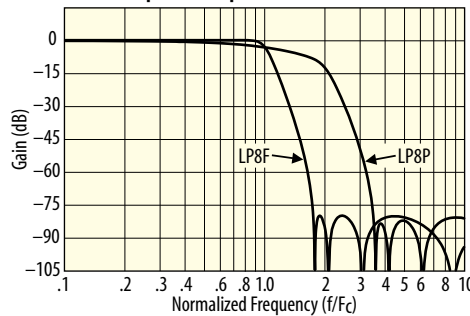

LP8P vs 8-Pole Bessel Amplitude Response

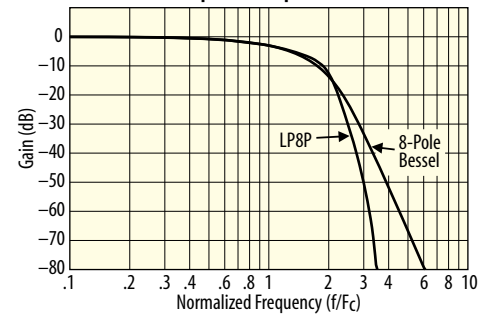

LP8F vs Butterworth Amplitude Response

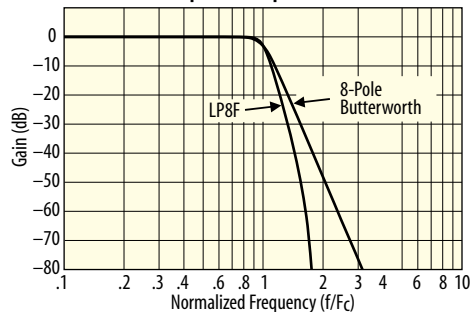

LP8F & LP8P Step Response

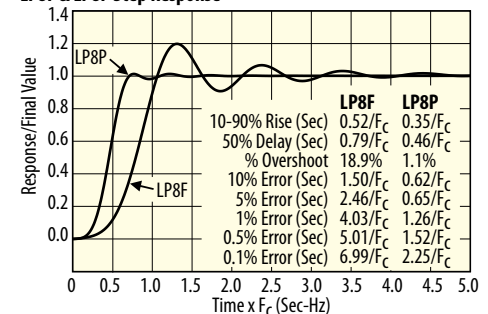

Output Characteristics

Primary (Rear Panel) Output: Output available at rear panel of chassis via 50-pin D connector (M3 chassis) or 26-pin high-density D connector (M5 chassis). For M3 chassis, one 50-pin D accommodates up to 16 primary outputs for four 28124-EA cards. For chassis with the M5 option, one high-density 26-pin D is available per card slot.

Auxiliary Outputs: Two female 15-pin D connectors available on the front panel of the 28124-EA card.

Type:

DC coupled, single-ended output with selectable ground sense

Output Ground Sense:

Used for driving grounded single-ended loads. Output is referred to ground at the load. Output sense also reduces ground loop interference by breaking the connection between the load ground and the 28124-EA channel ground.

Impedance:

Hi Output: $10\ \Omega // 100\ \text{pF}$
 Low Output (Sense Input):
 $100\ \Omega // 100\ \text{pF}$ or ground via manual card switch.

Output Shield:

Chassis ground

Max Output:

$\pm 10\ \text{Vpk}$, $\pm 25\ \text{mA pk}$

Offset:

$< 5\ \text{mV}$ after auto-adjust at any gain setting

Offset Drift:

$1\ \mu\text{V}/^\circ\text{C}$, RTI + $150\ \mu\text{V}/^\circ\text{C}$ RTO

Noise:

$2.8\ \mu\text{V rms}$ RTI + $60\ \mu\text{V rms}$ RTO,
 3 Hz to 100 kHz

Crosstalk:

$-90\ \text{dB}$, DC to 100 kHz

Output Monitor:

A switch at the output of each channel allows for multiplexed connection to the 28000 chassis output monitor bus BNC connector for viewing the channel output with an external device.

28124-EA General Characteristics

28124-EA Card Size:

6.63 x 17.5 x 0.75 inches

Card Weight:

1.4 lb. net

Temperature:

$0^\circ\ \text{C}$ to $40^\circ\ \text{C}$ (operating);
 $-20^\circ\ \text{C}$ to $70^\circ\ \text{C}$ (storage)

Connectors:

The input connectors are integral to the 28124-EA card. Cutouts on the 28000 frames allow the input connector to pass through the backplane and to directly mate with the input cables.

Two 26-pin high-density D connectors are utilized for the 4 inputs (2 inputs per connector). Connectors have high quality machined gold plated pins/sockets.

28124-EA output connectors are integral to the 28000 System chassis. Three wires per output are provided to accommodate twisted/shielded cables. Two additional auxiliary outputs with ground sense capability are available via 15-pin DB connectors the front panel.

28124-EA Channel Block Diagram

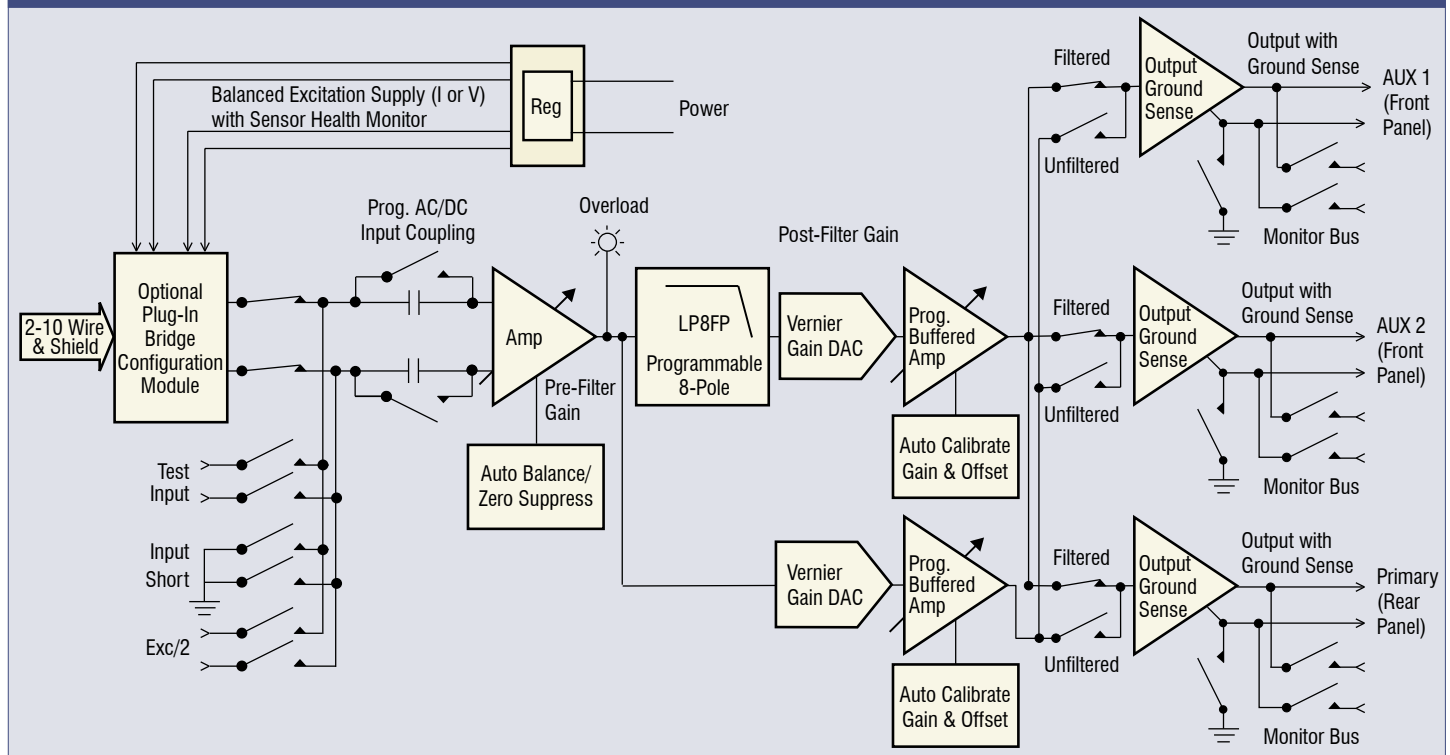

Accessories

Mating Connectors

Precision Filters mating connectors accommodate up to 22-AWG wire and are supplied with high quality metal backshells and gold plated screw machined contacts for high reliability connections and long service life.

CONN-IN-26D: High-Density 26-pin D-shell mating input connector with machined crimp pins and metal backshell with strain relief.

CONN-IN-26D-SC: High-Density 26-pin D-shell mating input connector with machined solder cup pins and metal backshell with strain relief.

CONN-OUT-26D: High-Density 26-pin D-shell mating output connector with machined crimp pins and metal backshell with strain relief.

CONN-OUT-26D-SC: High-Density 26-pin D-shell mating output connector with machined solder cup pins and metal backshell with strain relief.

CONN-OUT-15D: 15-pin D-shell mating output connector with machined crimp pins and metal backshell with strain relief.

CONN-OUT-15D-SC: 15-pin D-shell mating output connector with machined solder cup pins and metal backshell with strain relief.

CONN-OUT-50D: 50-pin D-shell mating output connector with crimp pins and backshell with strain relief.

CONN-OUT-50D-SC: 50-pin D-shell mating connector with solder cup pins and backshell with strain relief.

Ordering Information

28124-<LP8FP>-EA

Filter Specification:
8-pole low-pass (LP8FP)

BC6, BC7, BC8, BC9, BC12 Programmable Bridge Configuration Module:

One module is required per 28124-EA card to support bridge completion or DC shunt cal options.

Precision PF-1U-FA Multi-Channel Programmable Filter/Amplifier System



Exceptional desktop performance.

Ideal for conditioning low-level voltage inputs in front of high-resolution digital data acquisition systems. Fully programmable 8-channel and 16-channel configurations are available, both offering a choice of either 4 or 8-pole low-pass filters with programmable gain.

High Density Programmable Switch Systems

Computer controlled analog signal switching replaces tedious manual patch panels.



Precision 4164 64x64 Switch Matrix System



Precision 464kB Switch Matrix System

Precision switch systems are reliable solid-state switch matrix systems, providing computer-controlled connection between input and output signals. Configure the 464kB with up to 256 inputs and 256 outputs, all in a single mainframe, or choose the compact 4164 system with 64 inputs and 64 outputs. Save time and reduce errors on test system setup. Download switch configurations from the host computer over the network. Built-in self-test with fault diagnostics.