

## 464kB SALIENT FEATURES

---

- 3-stage non-blocking solid state switch matrix
- High density: 65,536 equivalent cross points in one mainframe
- Matrix sizes to meet unique requirement: 256 x 256, 224 x 224, 192 x 192, 160 x 160, 128 x 128 and 96 x 96
- Bus frames to form larger systems: 256 x 512, 512 x 256 and 512 x 512, for example
- Built-in self tests with diagnostics to verify the integrity of the switch system and user setup
- Remote control via Ethernet or RS-232
- Graphical user interface for computer control
- Non-volatile storage of switch configurations: five setups can be stored in the system, unlimited setups can be stored on host computer
- Signal switching of  $\pm 10$  Vpk for each signal path
- Frequency range: DC to 1 MHz
- Modular construction using plug-in cards
- Differential input
- Switch selectable output ground sense or single-ended output operation
- Monitoring of power supply, fans and internal temperatures

## 464kB DESCRIPTION

---

The 464kB is a 3-stage non-blocking solid state switching system which can provide the equivalent of a 256 x 256 rectangular coordinate switch with 65,536 cross points while using only 24,064 cross points. It uses 63% less cross points than a 256 x 256 rectangular coordinate switch, providing significant economy for large switching systems. This economy, as well as one-third the capacitive loading, is the main advantage of 3-stage switching systems.

The 464kB is a robust switching system that provides a uni-directional signal path from input to output while power is applied to the system. The System 464kB can be controlled from the front panel, or remotely using command line control or by running a graphical user interface on the host computer.

The 464kB uses its test subsystem to verify the system integrity. A Go/No-Go test checks the integrity of the current setup. Running the FAT (Factory Acceptance Test) exhaustively tests all possible switch settings and reports which plug-in modules are defective.



Figure 1 464kB Switching System, Front Panel

## SYSTEM OPERATION

---

Switch settings can be entered or verified using the graphical user interface, front panel or remote interface. Built-in Go/No-Go self test will verify that the unit has made the expected connections. Tests can be run unattended and diagnostics isolate problems down to the card level.

### Setting Up Your Programmable Patch

Although the 464kB is a 3-stage switching system, the operator should consider the system as a familiar coordinate matrix and tabulate the inputs that are to be connected to each output; the 464kB firmware will handle the 3-stage switching.

A switch setup can be constructed easily by listing inputs and outputs and identifying the desired cross points.

It's easy to enter the cross points into memory. With the list, select the output and enter the input. Step to the next output and enter the input. You can quickly enter the cross points for a large matrix.

Setups can be uploaded and downloaded in text format through the remote interface so you can do your programming off-line and download to your switch system.

The front panel menu and controls provide a convenient way to set up the switch system. There's computer control available, of course, via the remote interface. Unlimited setups can be stored in the host computer using the graphical user interface.

<b>IN</b>	<b>OUT</b>	<b>SET</b>	<b>Remote:</b>
63 *	31	0	OFF
			Status:
			OK

The IN OUT columns indicate a current input-to-output connection. The number on the left side is the input. The number on the right side of the asterisk is the output. The 256 x 256 matrix has 256 inputs (0 through 255) and 256 outputs (0 through 255).

In the menu above, input 63 is connected to output 31. Connections are entered at the numeric keypad using the \* key. The key sequence 16 \* 32 for example, connects input 16 to output 32.



**Figure 2 464kB Keypad**

The menu also displays system status information. The Remote field indicates whether the system is operating under front panel control or via the remote interface. The Status field is updated to indicate system faults.

To review switch settings, step through the outputs by pressing the + and – keys in the numeric keypad, and note the displayed input connections. Or display a specific output with the \* key. For example, \* 24 displays the connection for output 24.

**SET:** indicates which of five setups is selected as the active set for the matrix. The five setups, Set 1 through Set 5, are stored locally on the switch in non-volatile memory. The system always powers up with the programmed settings for the Active Set when power was removed.

## Remote Operation

Programming the switch system from a host computer is as easy as operating it at the front panel. System setups programmed at the front panel can be up-loaded to the host computer and stored. A stored setup can be down-loaded from the host computer, eliminating programming effort altogether. Remote commands are in plain English and are similar to the front panel menu. This command sequence defines two switch closures for Set 1 of matrix 1.

Command	Description
<b>SET:1;</b>	Select Set 1 for configuration.
<b>reset;</b>	Reset (open) all switches in Set 1.
<b>15*0;</b>	Connect input 15 to output 0.
<b>12*2;</b>	Connect input 12 to output 2.

## Verifying Setups

You can read and verify from the front panel that the switch settings are in memory. Or you can call for status via the host computer.

Command	Description
<b>SET:?</b>	Report the active setup.
<b>?*0;</b>	Report the input connection for output 0.
<b>?*2;</b>	Report the input connection for output 2.

## SYSTEM HEALTH AND MAINTENANCE

The system control monitors the status of the power supply, the cooling fans, and internal temperatures. If a failure is detected, an audible warning and front panel FAULT LED are activated and fault reports are available.

The System 464kB uses a built-in Test Subsystem to verify the integrity of the switch system and can be run unattended with automated reporting. Low level tones are injected into the signal path and the signal is measured at the inputs and outputs with a high impedance synchronous detector/ADC. The test system diagnostic reports those plug-in modules which are not functioning properly so that the faulty plug-in module can be replaced with a spare and the test rerun to verify system integrity.

Two types of tests are available. A pair of FAT tests (Factory Acceptance Test) can be used to perform an exhaustive test of all switch settings, internal switch connections, and input/output connectors. The Go/No-Go test check the integrity of the current setup and can be performed in situ, with all input and output cables connected. The individual tests are described in more detail below.

# SWITCH SYSTEM SPECIFICATIONS

## Input Characteristics

- Differential Input:  $\pm 10$  Vpk, linear
- Common Mode Input:  $\pm 20$  Vpk, linear
- Protection:  $\pm 40$  Vpk maximum, without damage
- Input Z:  $40\text{ k}\Omega$  differential  $\pm 0.1\%$
- CMRR: 88 dB typical, 70 dB minimum

## Transfer Characteristics

- Frequency Response: DC to 16 kHz  $0\text{ dB} \pm 0.02\text{ dB}$   
 16 kHz to 100 kHz  $0\text{ dB} \pm 0.05\text{ dB}$   
 100 kHz to 300 kHz  $0\text{ dB} \pm 0.25\text{ dB}$   
 300 kHz to 1MHz  $0\text{ dB} \pm 1.0\text{ dB}$   
 2 MHz  $-5\text{ dB}$  typical
- Level vs. Frequency:  $\pm 10$  Vpk for  $f \leq 200\text{ kHz}$   
 $\pm 10$  Vpk (200 kHz/f) for  $f > 200\text{ kHz}$
- Gain:  $0\text{ dB} \pm 0.002\text{ dB}$  at 16 kHz typical
- Linearity:  $\pm 0.01\%$  at 7 Vrms and 16 kHz
- Noise:  $25\text{ }\mu\text{Vrms}$  in 100 kHz BW typical,  
 $150\text{ }\mu\text{V}$  maximum
- Channel Crosstalk:  $-90\text{ dB}$ , maximum, at 16 kHz  
 $-75\text{ dB}$ , maximum, at 100 kHz  
 $-55\text{ dB}$ , maximum, at 1 MHz
- Phase Match:  $\pm 0.2^\circ$  maximum, DC to 10 kHz  
 $\pm 1^\circ$  maximum, 10 kHz to 100 kHz  
 $\pm 2^\circ$  Maximum, 100kHz to 200 kHz
- Delay: 750 ns typical
- Slew Rate:  $20\text{ V}/\mu\text{s}$  typical
- Recovery Time:  $< 1\text{ }\mu\text{s}$  w/50% overload

## Output Characteristics

- Output Type: Single-ended with switch selectable ground sense
- Maximum Output:  $\pm 10$  Vpk at 5 mA pk
- Output Z:  $50\text{ }\Omega$
- Output Offset:  $\pm 0.6\text{ mV}$  typical with input shorted,  
 $\pm 5\text{ mV}$  maximum

## 464kB System Frequency Response at 250mVp (dB)

(w/ max & min bars)

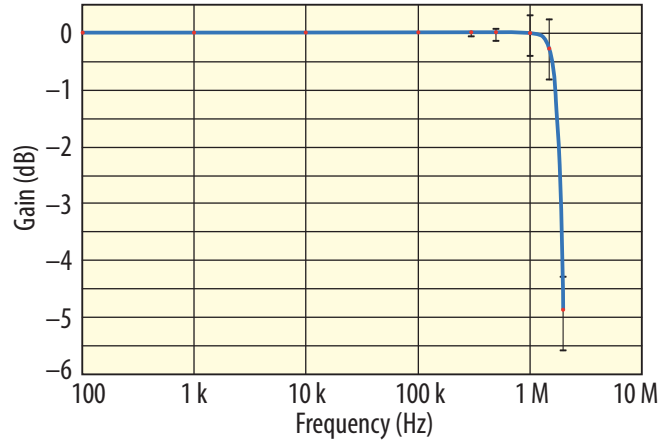

Figure 3 464kB Frequency Response

## 3-STAGE SWITCHING SYSTEM

On the block diagram below, a non-blocking, 3-stage switching system is depicted with 8 input cards (IN 1 through IN 8), 8 output cards (OUT 1 through OUT 8), and 8 interstage switch modules (INT 1 through INT 8). The midplane provides the interconnections between the input, output, and interstage cards. Each input card and each output card has two multipin connectors for I/O and two multipin connectors for bussing signals. The 50-pin "D" connectors can handle 16 differential signals.

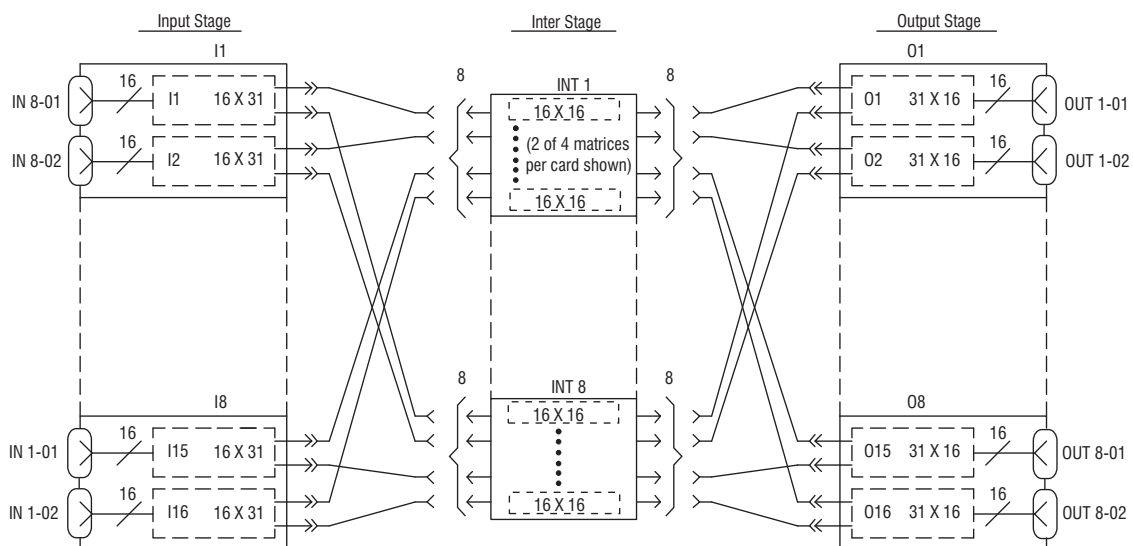

Figure 4 Block Diagram of a 3-Stage Non-Blocking Switch System

## 464kB SYSTEM COMPONENTS

Table 1 identifies the components that are supplied with each standard 464kB switch system and lists additional accessories that are available from Precision Filters.

### MAINFRAME

The 464kB begins with a 464kB-R1 mainframe with front panel and integral midplane. Input cards, output cards and eight interstage switch modules are interconnected by the midplane. Also interconnected are the control module, front panel, test subsystem and power.

The front panel provides the controls and displays for manual operation of the system.

The mainframe is 19 inches wide, 17.5 inches high, and 15 inches deep and is designed to fit in a standard 19-inch RETMA rack.

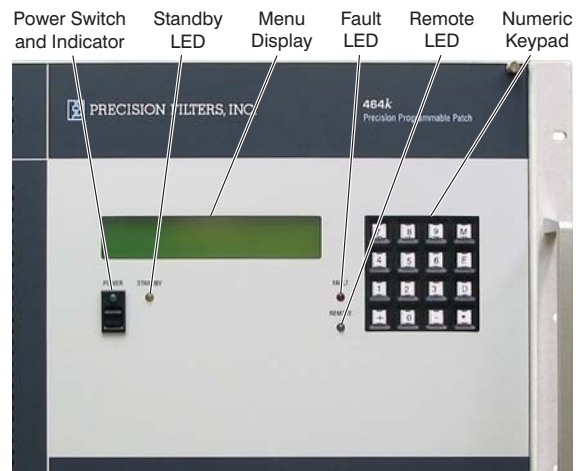

Figure 5 464kB Front Panel Controls and Indicators

### POWER SUPPLY

The standard 464kB-ACPS plug-in power supply lets you operate at 100, 120, 230 or 240 VAC and frequency may range from 47 to 66 Hz. The field replaceable power supply is located at the left end of the rear panel.

Table 1 464kB System Components

Components Supplied with System							
Model Number	Description	464kB Matrix Size					
		256x256	224x224	192x192	160x160	128x128	96x96
464kB-R1	Basic chassis with front panel and integral midplane	1	1	1	1	1	1
464kB-ACPS	Power supply	1	1	1	1	1	1
464kB-C5-S1T	Controller with 10/100 BaseT and RS-232 control interface	1	1	1	1	1	1
464kB-I-MP2-(2)16X31	Input Cards	8	7	6	5	4	3
464kB-O-MP2-(2)31X16	Output Cards	8	7	6	5	4	3
464kB-INTER-(4)16X16	Interstage Cards	8	8	8	8	8	8
464k-BP1A	Blank Rear Panel, 1-Slot	0	2	0	2	0	2
464k-BP2	Blank Rear Panel, 2-Slots	0	0	2	2	0	0
464k-BP4	Blank Rear Panel, 4-Slots	0	0	0	0	2	2
464k-GUI-WIN	Graphical User Interface	1	1	1	1	1	1
464k-TEST-WIN	FAT Software	1	1	1	1	1	1
464kB System Accessories							
SM??B	Slide Mount Kit: ?? = Cabinet Rail Depth: 18, 20, 22 or 24 Inches	1	1	1	1	1	1
464k-I-SHORT	Input Shorting Plugs, FAT 0	16	14	12	10	8	6
464k-I/O-TEST	Test Cables for FAT 1	2	2	2	2	2	2
CONN-OUT-50D or CONN-OUT-50D-SC	Mating Conn. for MP2, Crimp Pin or Solder Cup (SC)	32	28	24	20	16	12
464k-CABLE-??x???	Cable Set with MP2 to Bulkhead Mount BNC's	1	1	1	1	1	1
464-kPNL-128	Panel for Bulkhead Mount, 128 BNC's	4	4	3	3	2	2

## CONTROL MODULE

The 464kB-C5-S1T control module provides programming commands to the I/O and Interstage modules. When an operator requests an input to be connected to an output, the controller calculates the optimal path through the switch and selects the proper cross points. The control module operates the front panel display, reads input keys and processes commands from the remote interface(s). The control is located at the rear panel, next to the power supply. The 464k-LCS Command Line Interface is included.

The control module also provides 10/100 baseT Ethernet and RS-232C remote interfaces. IP address and port configurations are set using a front panel menu sequence. The IP assignment is static. RS-232C is also configured through the front panel. Standard baud rates are available from 9600 to 115200.

The control module also monitors the status of the power supply, cooling fans and internal temperature. If a failure is detected, an audible warning and front panel FAULT LED are activated.

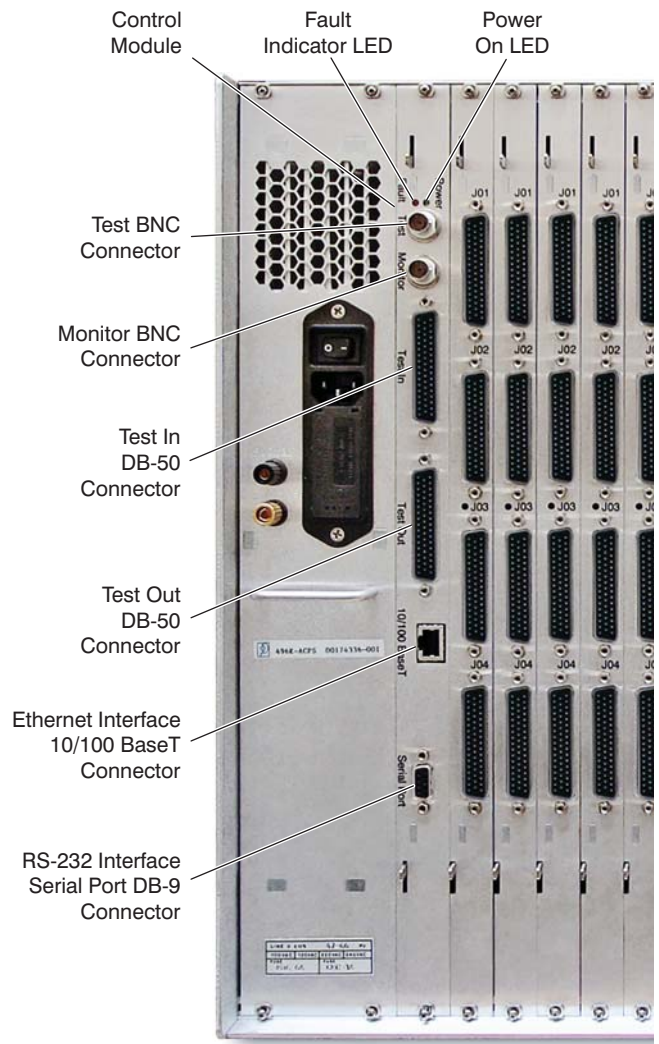

Figure 6 464kB-O-MP2-(2)31X16 Input Card

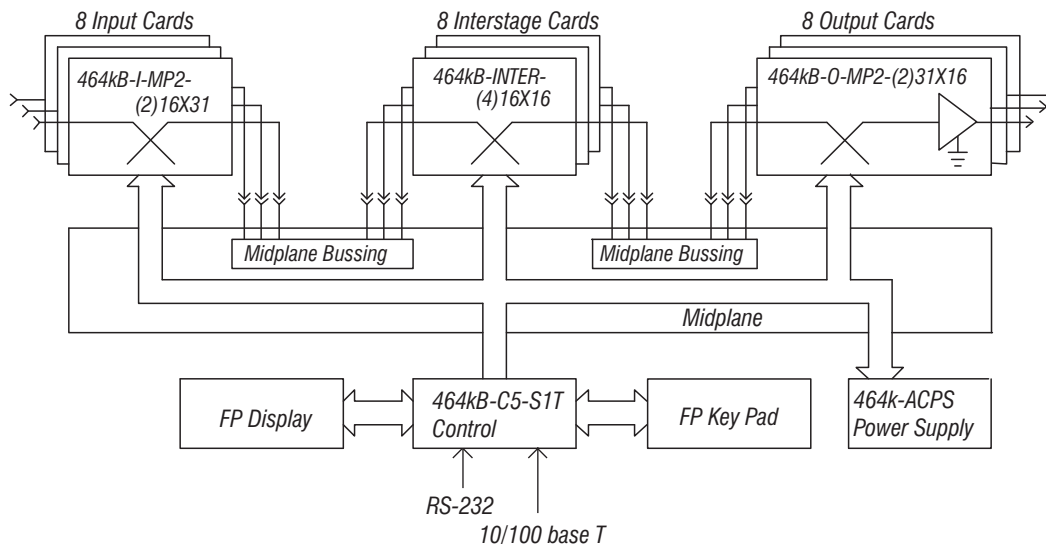

Figure 7 Elements of the 464kB Switch System (256x256 Configuration)

## 464kB INPUT & OUTPUT CONNECTOR CARDS

Input and output connections are made on plug-in connector cards. The number of input cards and output cards is determined by the size of the matrix.

The output card provides switch selectable output ground sense. Each channel's output can be set for either ground sense or single ended output operation.

The input and output cards provide bussing connectors for "T"ing the inputs or outputs of multiple mainframes. This feature provides the ability to "T" together inputs of multiple mainframes to form larger switch systems.

464kB-I-MP2-(2)16X31 The input card provides 32 differential inputs distributed to two 50-pin D connectors with two 50-pin bussing connectors.

464kB-O-MP2-(2)31X16 The output card provides 32 buffered outputs with selectable ground sense distributed to two 50-pin D connectors with two 50-pin bussing connectors.



Figure 9 464kB-I-MP2-(2)16X31 Input Card

## 464kB INTERSTAGE CARDS

Each interstage switch module is a solid state switch matrix. Eight interstage switch modules plug into the midplane for each matrix. The cards are accessible behind the hinged front panel.

Each 464kB-INTER-(4)-16x16 interstage card provides four 16x16 matrices.



Figure 8 464kB-R1 w/Input Cards and Output Cards Installed



Figure 10 464kB Interstage Cards Installed

## TEST SUBSYSTEM

The 464kB incorporates a test subsystem that provides the capability to perform a variety of performance tests including comprehensive factory acceptance tests (FAT) and a Go/No-Go test. A suite of tests identify and report those plug-in modules which are not functioning properly so that they can be replaced in the field. Test reports are generated and can be saved.

464kB tests can be performed at any time following power up. Test performance is most accurate if the system has been powered up for one hour or more to insure proper warm up.

### FAT0 Test

The FAT0 test functionally tests each board installed in the mainframe. This test is performed with all I/O cables disconnected and special grounding plugs installed on the sixteen input connectors (464k-I-SHORT). Two characteristics are measured in FAT0: matrix gain and crosstalk at 16 kHz. Measurements exceeding factory set limits will be reported in a test report.

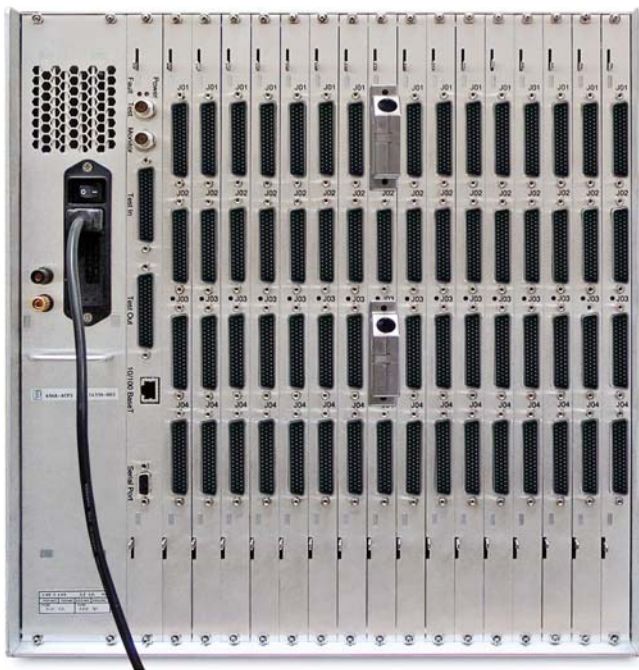

**Figure 11 464k-I-SHORT Input Grounding Plugs Installed for FAT0 Test**

Using the built-in test and monitor busses on each board, test signals are injected into each signal path. The monitor bus selects the test signal to be measured. The test subsystem uses a synchronous detector or RMS detector to measure the monitored signal.

The FAT0 test checks each path through an individual card, then checks for crosstalk on all other channels of the same card. Finally the test breaks the test connection to verify that the switch can be opened.

The FAT0 test can be run from the front panel menus, or under control of the 464k-GUI-WIN graphical user interface or the 464k-LCS command line interface. The FAT0 Test takes approximately 13 hours to complete.

### FAT1 Test

The FAT1 test checks all input connectors (4 connectors on each of 8 cards), all output connectors (4 connectors on each of 8 cards), and the connections between them, including the midplane and interstage cards. This test is run with all input and output cables disconnected and special test cables installed (464k-I/O-TEST, PF pn A10685G1, 2 ea.).

The FAT1 test can be initiated from the front panel menus, or under control of the 464k-GUI-WIN graphical user interface or the 464k-LCS command line interface. The 464k-LCS command set supports testing of a single user-selected card pair. Once initiated the test is run using the front panel controls and display. The FAT1 test procedure provides a series of directions for connecting test cables and moving them during the test.

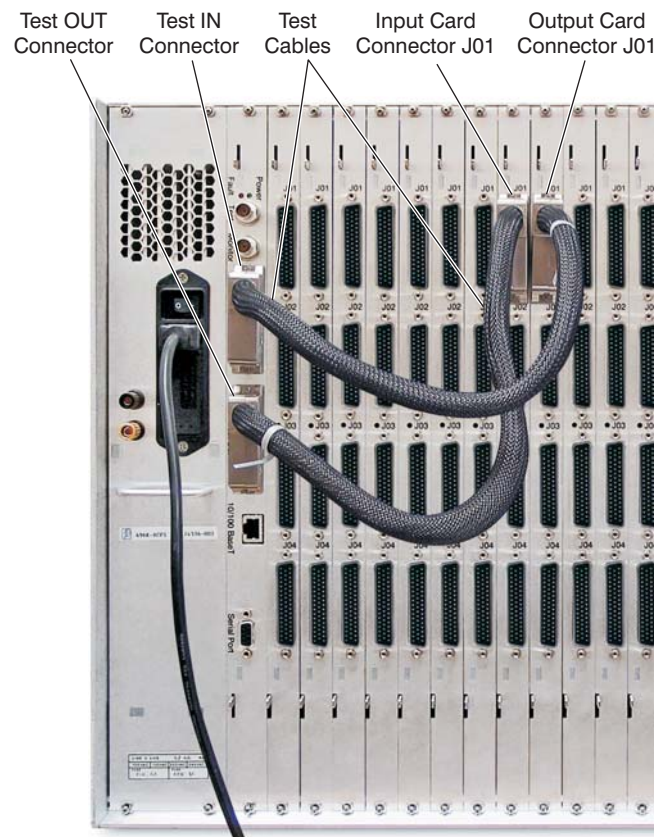

**Figure 12 464k-I/O-TEST Test Cables Installed for FAT1 Test**

## FAT1 Test (continued)

During the FAT1 Test connections between each input card and all interstage cards and output card are tested. The connections between each output card and all interstage cards are tested. All midplane connections between input cards, output cards and interstage cards are tested. All I/O connectors are tested. The FAT1 test takes approximately 20 minutes to complete.

## Go/No-Go Test

The Go/No-Go test checks the integrity of the current matrix configuration. The test is performed in situ with I/O cables attached and no signal paths are changed during the test. A check of each programmed connection from the input card, through the interstage card, to the output card is tested.

The test can be run using the front panel menus or under control of the 464k-GUI-WIN graphical user interface or the 464k-LCS command line interface. The Go/No-Go test takes approximately 5 minutes to complete.

The Go/No-Go routine tests a user setup for correct gain measurement. A test signal is measured and injected at the input card. This signal is then measured at the output of the signal path. The resulting gain is calculated. The process is repeated for each programmed path of the user setup.

## Typical Performance Characteristics

### Frequency Response

#### Gain at .250V peak at 100kHz

Min = -14.0 mdB Max = -4.9 mdB  
Mean = -9.6 mdB Std. Dev. = 1.7 mdB

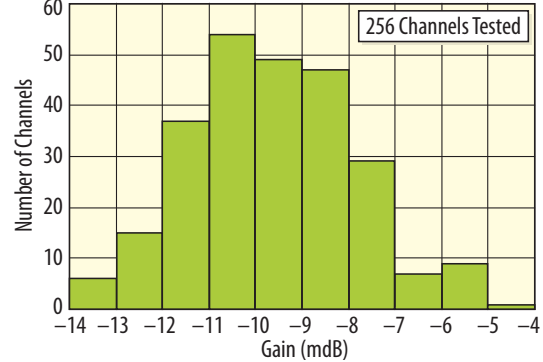

#### Gain at .250V peak at 300kHz

Min = -50.0 mdB Max = 26.6 mdB  
Mean = -12.1 mdB Std. Dev. = 14.3 mdB

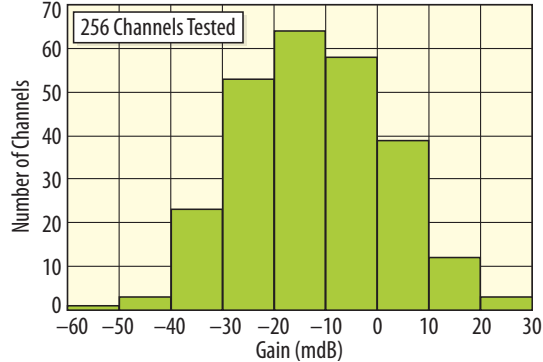

#### Gain at .250V peak at 500kHz

Min = -121.3 mdB Max = 89.2 mdB  
Mean = 13.3 mdB Std. Dev. = 39.2 mdB

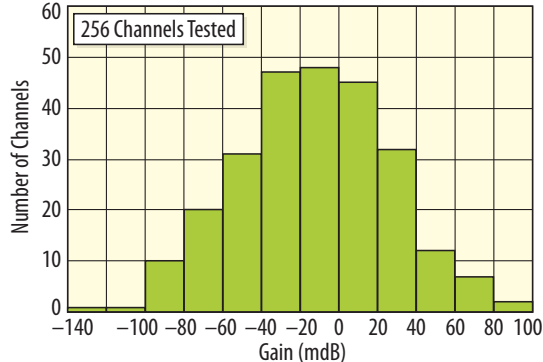

#### Gain at .250V peak at 1MHz

Min = -411.1 mdB Max = 307.9 mdB  
Mean = -17.9 mdB Std. Dev. = 142.8 mdB

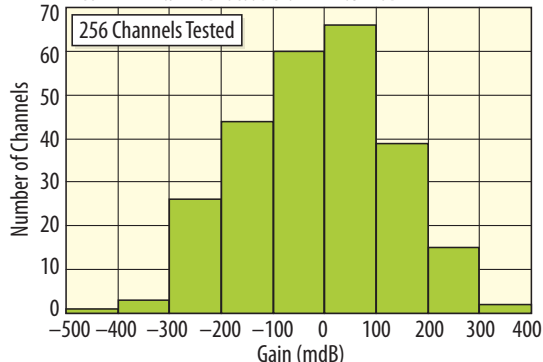

# Typical Performance Characteristics (continued)

## Gain

### Gain at 9V peak at 16kHz

Min = -4.0 mdB    Max = -0.30 mdB  
 Mean = -2.12 mdB    Std. Dev. = 0.54 mdB

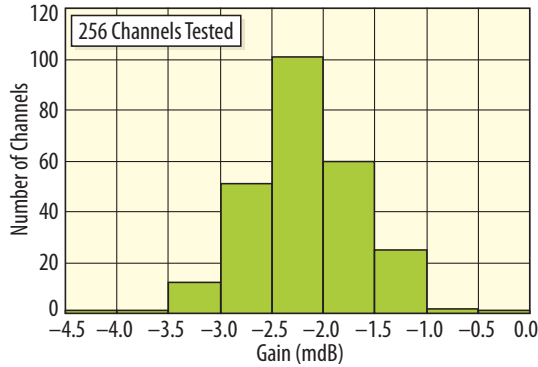

## DC Offset

### DC Offset RTO

Min = -2.63 mV    Max = 1.82 mV  
 Mean Dev. = 0.12 mV    Std. Dev. = 0.72 mV

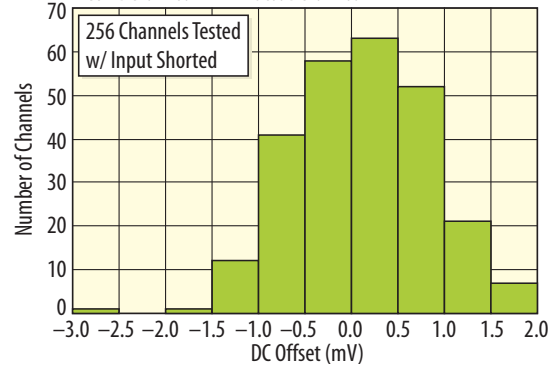

## Linearity

### Linearity ((Gain 9V - Gain 1V)/Gain 1V)\*100

Min = -0.007 %    Max = 0.002 %  
 Mean Dev. = +/- 0.002 %    Std. Dev. = 0.002 %

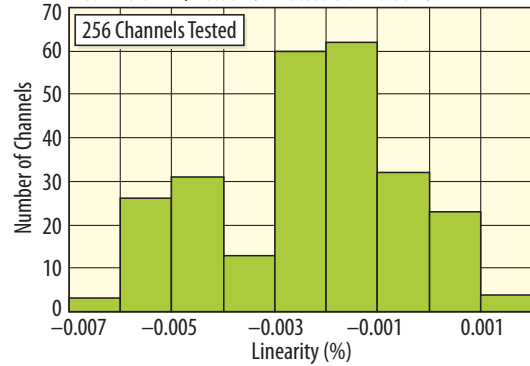

## Noise

### 100kHz BW Noise RTO

Min = 19.4 μV    Max = 68.5 μV  
 Mean = 25.7 μV    Std. Dev. = 6.0 μV

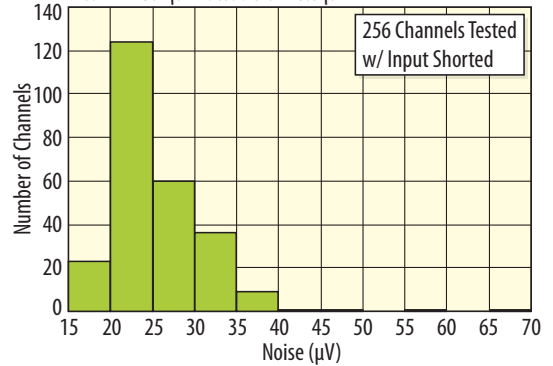

## Common Mode Rejection Ratio

### Common Mode Rejection Ratio @ 9Vp & 60Hz (dB)

Min = -114.1 dB    Max = -72.5 dB  
 Mean = -87.7 dB    Std. Dev. = 7.7 dB

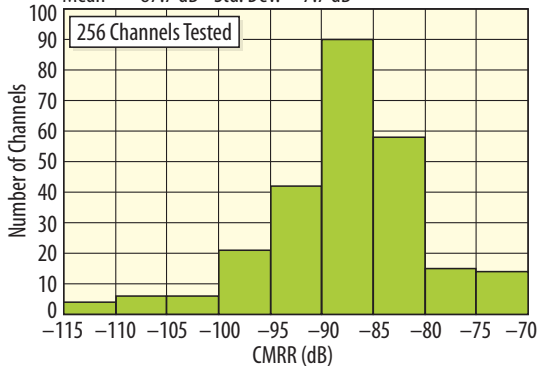

## Crosstalk

### Crosstalk @ 9Vp & 16kHz

Min = -177.3 dB    Max = -93.8 dB  
 Mean = -133.2 dB    Std. Dev. = 9.6 dB

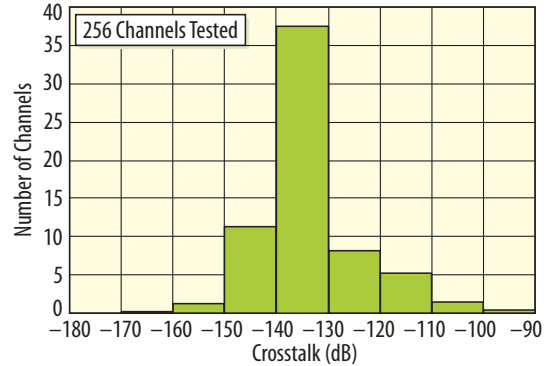

# Typical Performance Characteristics (continued)

## Recovery Time from System Overload

### Negative Recovery from a Full-Scale Signal

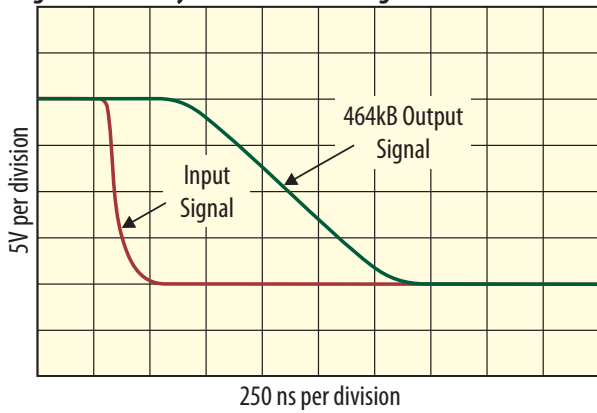

### Negative Recovery from a 150% Full-Scale Signal

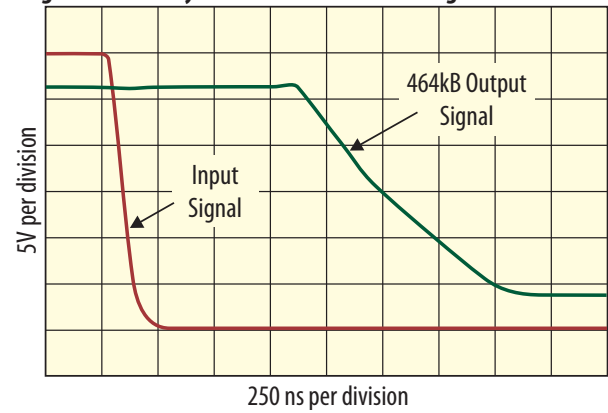

### Positive Recovery from a Full-Scale Signal

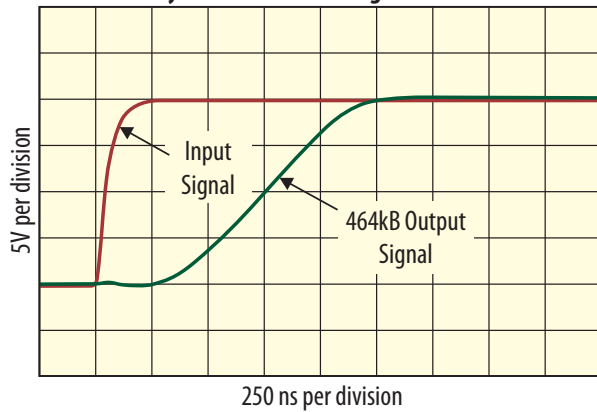

### Positive Recovery from a 150% Full-Scale Signal

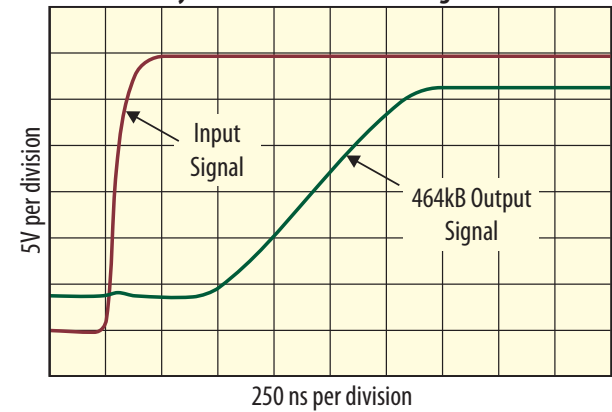

## BUSSING FRAMES TO FORM A LARGER SWITCH SYSTEM

The size of a switch system need not be limited by the capacity of a single mainframe. Larger switch systems are obtained by bussing mainframes.

### Bussing Outputs to Expand the Number of Outputs

To expand the number of inputs, use the "T" connections on each 464kB output card and cables to bus outputs.

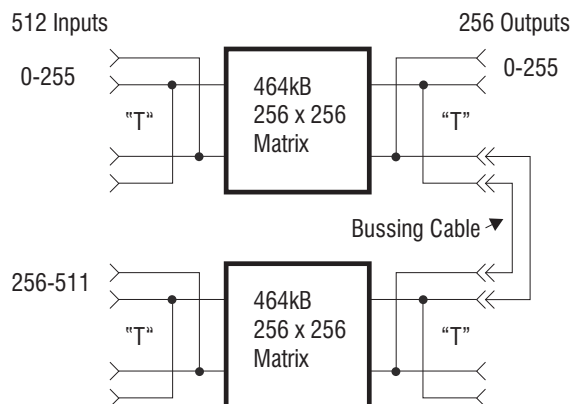

**Figure 13 Two Mainframes Configured for 512 x 256 Switch Using Output Bussing**

Table 2 lists the hardware and cables necessary to "T" two systems together to create a larger 512 x 256 switching system.

Table 2 464kB Two-Frame System Component Requirements for 256 x 512 or 512 x 256 Switch		
Qty.	Model	Description
2	464kB-R1	Basic Mainframes
2	464kB-ACPS	Power Supplies
2	464kB-C5-S1T	Controllers with 10/100 BaseT, RS-232 and Test Interface
16	464kB-I-MP2-(2)16X31	Input Cards
16	464kB-O-MP2-(2)31X16	Output Cards
16	464kB-INTER-(4)-16X16	Interstage Cards
2	SM??B	Rack Mount ?? = Rack Depth
32	464k-I-SHORT	Input Shorting Plugs for FAT0 Test
2	464k-I/O-TEST	Test Cables for FAT1 Test
2	464k-GUI-WIN	Graphical User Interface
2	464k-TEST-WIN	FAT Software
16	CB-MP2PP-6	Bussing Cables, MP2 Male to MP2 Male, 6 Ft. Length

### Bussing Inputs to Expand the Number of Outputs

To expand the number of outputs, use the "T" connections on each 464kB input card and cables to bus inputs.

Figure 14 illustrates the method by which two 256 x 256 switch systems employ input bussing to provide a 256 x 512 switch matrix. Table 2 identifies the hardware and cables required to form a 256 x 512 switch system.

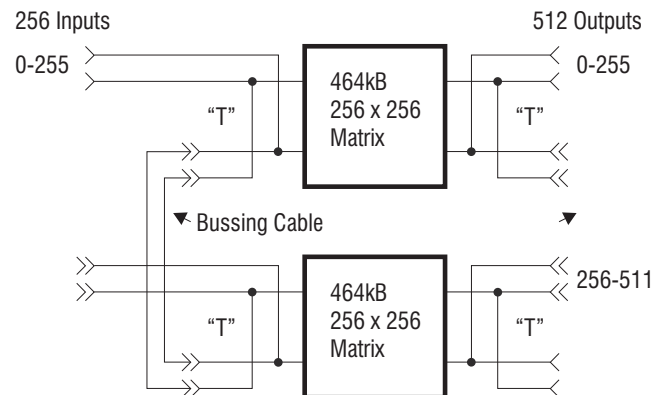
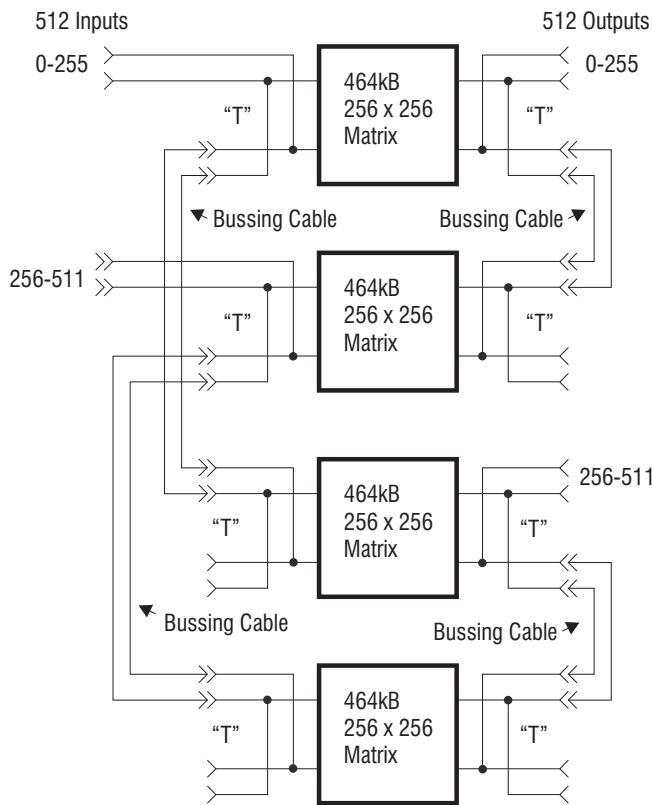

**Figure 14 Two Mainframes Configured for 256 x 512 Switch Using Input Bussing**

### Bussing Four Frames

Input bussing combined with output bussing is used to create larger switch systems. Figure 15 illustrates the use of input bussing and output bussing of four 464kB switch systems to configure a 512 x 512 matrix switch. Table 3 lists the required hardware to "T" four systems together to create a 512 x 512 switch matrix.

Table 3 464kB 512 x 512 Matrix, Four-Frame System Component Requirements		
Qty.	Model	Description
4	464kB-R1	Basic Mainframes
4	464kB-ACPS	Power Supplies
4	464kB-C5-S1T	Controllers with 10/100 BaseT, RS-232 and Test Interface
32	464kB-I-MP2-(2)16X31	Input Cards
32	464kB-O-MP2-(2)31X16	Output Cards
32	464kB-INTER-(4)-16X16	Interstage Cards
4	SM??B	Rack Mount, ?? = Rack Depth
32	464k-I-SHORT	Input Shorting Plugs for FAT0 Test
2	464k-I/O-TEST	Test Cables for FAT1 Test
4	464k-GUI-WIN	Graphical User Interface
4	464k-TEST-WIN	FAT Software
64	CB-MP2PP-6	Bussing Cables, MP2 Male to MP2 Male, 6 Ft. Length



**Figure 15 Four Mainframes Configured for 512 x 512 Switch Using Input and Output Bussing**

## MATING CONNECTORS, CABLES, AND TEST ACCESSORIES

CONN-OUT-50D	50-Pin Mating connector with crimp pins and strain relief, 20-24 gauge (PF pn A5092G1)
CONN-OUT-50D-SC	50-Pin Mating connector with solder cup pins and strain relief, 20-24 gauge (PF pn A5092G2)
CB-MP2PP-6	Cable, MP2 Male to MP2 Male, 6 ft. length
464k-Cable-???x???	Cable Set with MP to bulkhead BNC connectors and bulkhead panels
464k-I-SHORT	Input shorting plug, 16 required (PF pn A10686G1)
464k-I/O-TEST	464k Test Cables, 2 required (PF pn A10685G1)

## ENVIRONMENTAL REQUIREMENTS

Operating Temp:	0° C to 40° C
Storage Temp:	-20° C to 70° C
Relative Humidity:	Less than 80%, non-condensing

## PHYSICAL CHARACTERISTICS

Mainframe :	19 x 17.47 x 15 inches (WHD)
Weight:	Mainframe (PS, BP, FP), 50 lb. Interstage Card, 1.5 lb. Input or Output Card, 1.5 lb.

