



Precision 28708 Octal Programmable AC/DC Amplifier

The 28708 Octal Programmable AC/DC Amplifier Card provides eight channels of programmable amplifiers having an overall gain of x1/4 to x8192 with 0.05% resolution. A balanced differential input results in outstanding rejection of common-mode interference. A combination of low noise, low DC drift and wide bandwidth make the 28708 suitable to a wide range of static or dynamic applications. Features include a programmable AC/DC coupling and zero suppress for nulling the DC bias from attached transducers. Test and monitor busses allow the 28708 to integrate seamlessly with the 28000 Test Subsystem for built in performance verification.



28708 Salient Features

Number of Channels:

- 128 channels per 28016 chassis
- 64 channels per 28008 chassis

Inputs:

- Hi-Z, Hi-CMRR Balanced differential with programmable AC/DC coupling

Gain:

- x1/4 to x8192 with 0.05% resolution

Bandwidth:

- 200 kHz full power bandwidth, 500 kHz small signal bandwidth

Test Support:

- Test input enables insertion of calibration signals at the amplifier input
- Any channel output may be monitored via a single BNC connector

Control:

- Ethernet remote control
- Local control via supplied Windows based Graphical User Interface (GUI).

28708 Description

Designed for the Precision 28000 Signal Conditioning Systems, the Precision 28708 Octal Programmable Amplifier card allows for up to 128 channels in one 16-slot chassis or 64 channels in a single 8-slot chassis. Systems beyond 128 channels may be accommodated by multiple mainframes controlled from a single controller. Modular construction of the 28000 System allows for easy expansion.

The 28708 provides gain of x1/4 to x8192 with 0.05% resolution. A balanced differential input with programmable AC/DC input coupling results in outstanding rejection of common-mode interference. Low noise ($<-163 \text{ dBV}/\sqrt{\text{Hz}}$) and wide bandwidth make the 28708 useful for dynamic measurement applications. The DC accuracy of the 28708 is useful for static measurements. The zero suppress feature may be used as a transducer balance function or to zero DC offsets for the system. Manual and automatic suppress modes are supported.

The output stage contains load ground sensing circuitry to refer the amplifier output to the ground of a single-ended load and to eliminate ground loops for single-ended loads. Optional output adapter modules plug onto the front of the 28708 card to provide two additional buffered outputs per channel.

Inputs and outputs are interfaced via two high density 26-pin connectors at the rear of the 28000 chassis. Three wires are provided for each input and output. Input and output shields may be floated or terminated to signal ground via manual on-card switches.

For applications that require a programmable filter, please refer to the 28608B Octal Programmable Filter/Amplifier card specification sheet.

Overview

28000 Analog Signal Conditioning System

The new standard for the world's most discriminating test labs.



The Precision 28000 Signal Conditioning System provides all the flexibility you need to manage your test measurements.

The Precision 28000 makes it easy to manage a test with hundreds of channels and a mix of transducers. Choose charge, IEPE w/TEDS, voltage (filter/amplifier), strain, thermocouple, RTD, potentiometer, current, frequency, or other transducers.

The built-in test hardware and software (optional) provide quick go/no-go tests which can be run before each test, and rigorous factory acceptance tests to assure you that the 28000 meets your most stringent requirements for critical applications. It won't be long before these tests earn a permanent place in your maintenance routine. And since they are traceable to NIST, they eliminate the need for off-site calibration.

In every phase of your tests—record keeping, installation, design, set-up, operation, maintenance and upgrading—the Precision 28000 offers ways to help you save time and money over the life of the system.

28000 System Features

- Graphical User Interface (GUI) and Ethernet network interface for system control
- Intelligent gain and system scaling algorithms
- Test input and output monitor busses
- Go/no-go test with diagnostics to be used before tests
- Rigorous factory acceptance test for maintenance
- Field swappable AC power supplies
- Built-in temperature and power supply monitoring with alarms

Precision 28708 Description

28708 Amplifier Specifications

Gain:

x0.25 to x8192 with 5% resolution

Gain Control Modes:

Two gain control modes are supported by the Graphical User Interface for the 28708.

F_{sout}(V)/F_{sin}(V): Gain may be entered directly or gain is computed as the ratio of the user entry for the full-scale input and full-scale output levels in volts.

(F_{sout}(MU)/F_{sin}(V))*Sensor(V/MU): Enter transducer sensitivity (Volts per Measurement Unit), full-scale input (Measurement Units) and full-scale output (Volts). Gain is automatically computed.

DC Accuracy:

0.2% after auto-adjust at any gain setting

Temperature Coefficient:

±0.008% /°C

DC Linearity:

±0.01% re: Fullscale, relative to best straight line

Frequency Response:

DC to 200 kHz; 0 dB ±1%
-3 dB typical at 500 kHz

28708 Input Characteristics

Type:

Balanced Differential w/ programmable AC/DC input coupling

Input Impedance:

10 MΩ // 100pF per side

Max Level:

(AC + DC + Common Mode)
±10 Vpk for f ≤ 200 kHz
±10 Vpk x (200 kHz/f) for f > 200 kHz

Input Protection:

35 V
Offset Drift:
1 μV/°C, typical

Input Shield:

Selectable ground or open via manual card switch.

Noise:

7 nV/√Hz at 1 kHz and gain > 64, typical

AC Coupling Frequency:

0.25 Hz (-3.01 dB)

CMRR (DC Coupled):

100 dB, DC to 440 Hz, gain > x16

CMRR (AC Coupled):

80 dB, 10 Hz to 440 Hz, gain > x16

Input Short:

All amplifier inputs may be programmed to ground to measure amplifier noise and DC offset.

Test Input:

A switch at the channel input allows for injection of external test signal via an external 28000 chassis front panel BNC connector.

Zero Suppress:

Precision programmable DC offset is injected at the channel input stage to suppress the DC operating voltage. Manual or automatic suppression modes are supported.

Range:

-160 mV to +160 mV in 78 μV steps
-1.28 V to +1.28 V in 625 μV steps
-10.24 V to +10.24 V in 5 mV steps

Accuracy:

±0.25% of setting ±5 mV

28708 Channel Block Diagram

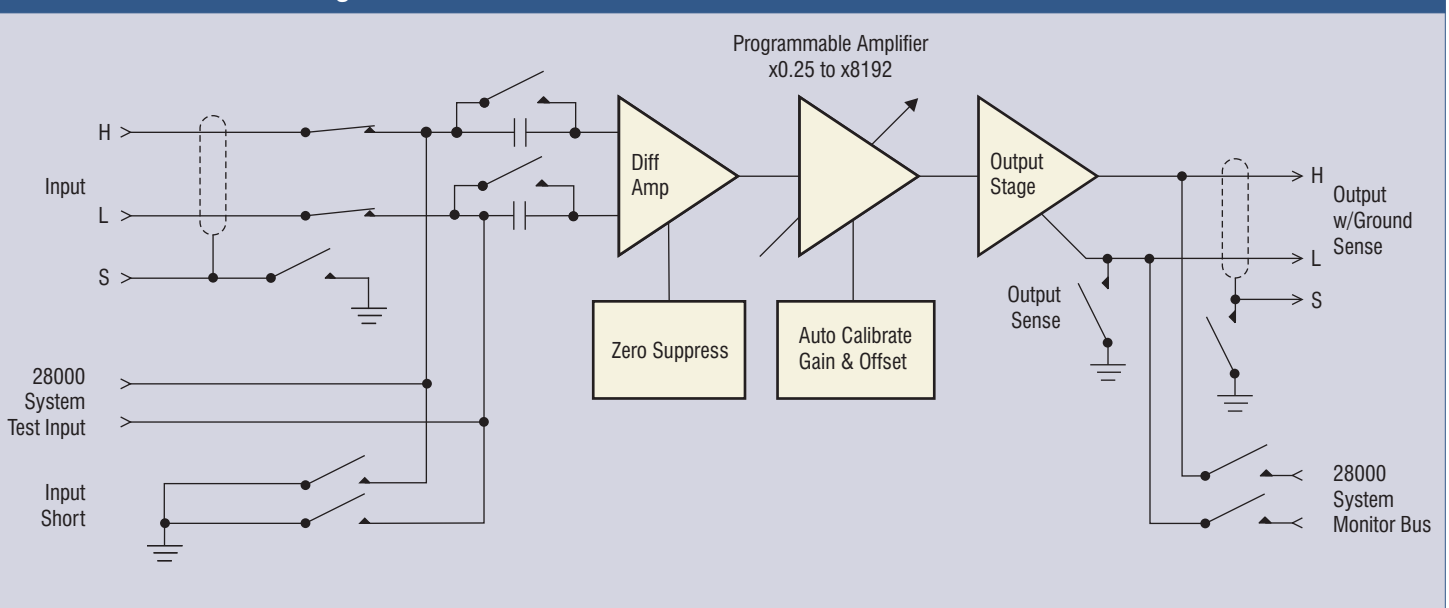

28708 Output Characteristics

Type:

DC coupled, single-ended output with ground sense

Output Ground Sense:

Used for driving grounded single-ended loads. Output is referred to ground at the load. Output sense also reduces ground loop interference by providing a high impedance connection between the ground at the load and the output stage ground.

Impedance:

Hi Output: 10 Ω // 100 pF

Low Output (Sense Input):

100 Ω // 100pF or ground via manual card switch.

Output Shield:

Selectable ground or open via manual card switch.

Max Output:

± 10 Vpk, ± 10 mA pk

Offset:

<5 mV after auto-adjust at any gain setting

Offset Drift:

1 μ V/ $^{\circ}$ C, RTI + 100 μ V/ $^{\circ}$ C RTO

Noise:

2.8 μ V rms RTI + 40 μ V rms RTO
3 Hz to 100 kHz

Crosstalk:

-90 dB, DC to 100 kHz

Output Monitor:

A switch at the output of each channel allows for multiplexed connection to the 28000 chassis output monitor bus BNC connector for viewing the channel output with an external device.



Rear Panel Input and Output Connectors

128-Channel Amplifier System Block Diagram

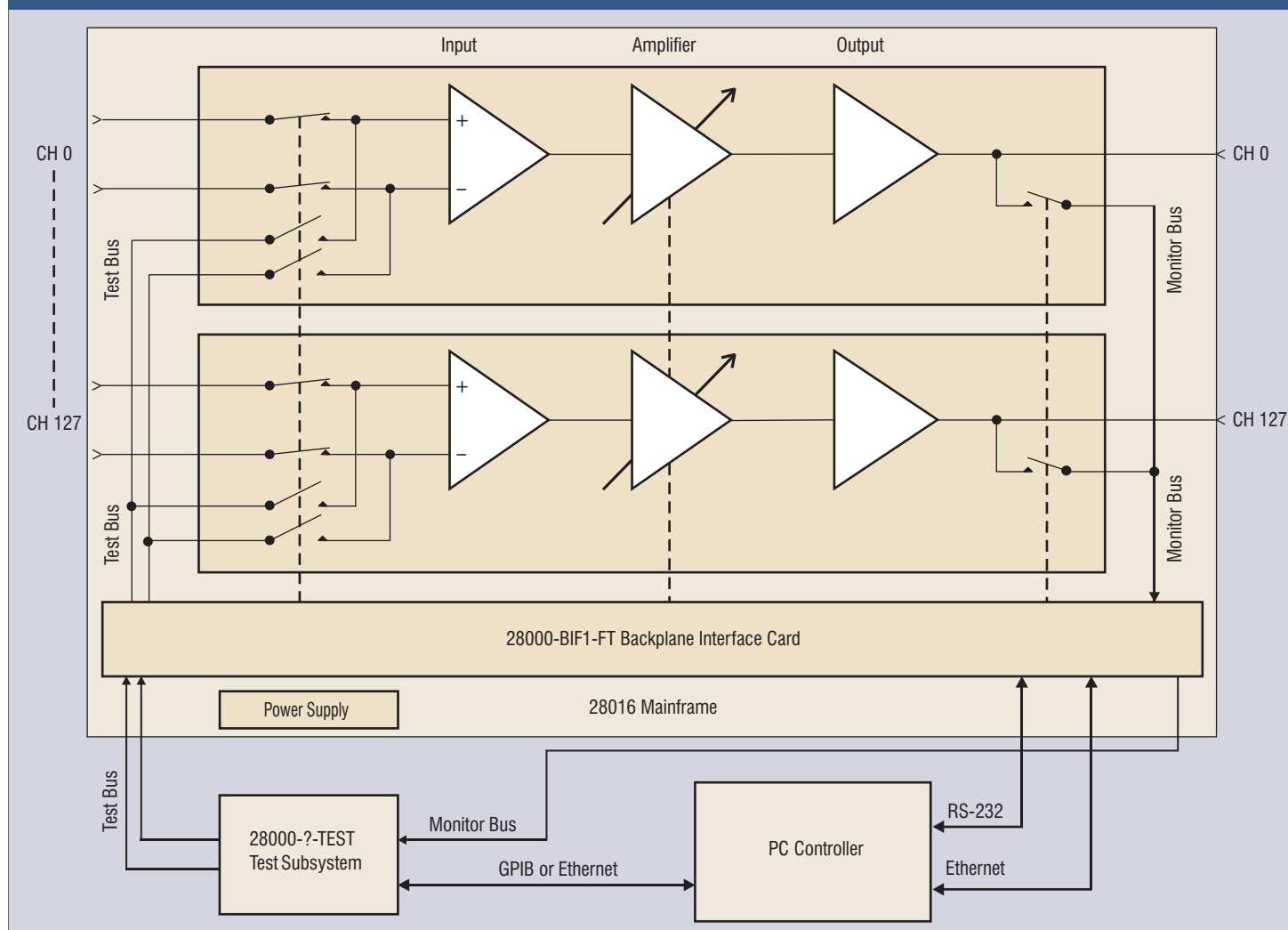

28708 General Characteristics

28708 Card Size:

6.63 x 17.5 x 0.75 inches

Card Weight:

1.4 lb. net

Temperature:

0° C to 40° C (operating)
–20° C to 70° C (storage)

Connectors:

The input and output connectors are integral to the 28708 card. Cutouts on the 28000 frames allow for the input and output connectors to pass through the backplane to directly mate with the input/output cables. One 26-pin high density D connector is utilized for the 8 inputs and one 26-socket high density D connector is used for the 8 outputs. Three wires per input or output are provided in order to accommodate twisted/shielded cables. Connectors have high quality machined gold plated pins/sockets.

Ordering Information

28708-1-AMP

Accessories

Mating Connectors

Precision Filters mating connectors accommodate up to 22 AWG wire and are supplied with high quality metal backshells and gold plated screw machined contacts for high reliability connections and long service life.

CONN-IN-26D-MTL:

High-Density 26-pin D-shell mating input connector with machined crimp pins and metal backshell with strain relief.

CONN-IN-26D-SC-MTL:

High-Density 26-pin D-shell mating input connector with machined solder cup pins and metal backshell with strain relief.

CONN-OUT-26D-MTL:

High-Density 26-pin D-shell mating output connector with machined crimp pins and metal backshell with strain relief.

CONN-OUT-26D-SC-MTL:

High-Density 26-pin D-shell mating output connector with machined solder cup pins and metal backshell with strain relief.

Output Adapter

Measurement systems sometimes require multiple outputs per signal conditioning channel. These outputs may be routed to control systems, tape backup systems, auxiliary data acquisition systems, scope bays and other destinations.

28708 cards are fitted with front panel connectors that accept the output adapter modules. Adapters plug onto the front of the signal conditioner card and are secured to the card by two screws. The adapters provide two additional fully buffered outputs per channel on two high-density 26-pin D shell connectors.

BUFF-8CH/(2)HD26D:

Dual output buffer for 8-channel cards with two sets of eight outputs on two high-density 26-pin D connectors.

Precision Product Solutions

For over 30 years Precision Filters has been a global provider of instrumentation for test measurements. You can rely on a single source for signal conditioning and switching—a *complete range of instrumentation*—products optimized to work together to provide high performance at reasonable cost.

Precision Products

Precision PF-1UA-FA Multi-Channel Programmable Filter/Amplifier System



**Exceptional desktop performance
at low cost.**

Ideal for conditioning low-level voltage inputs in front of high-resolution digital data acquisition systems. Fully programmable 8-channel and 16-channel configurations are available, both offering a choice of either 4- or 8-pole low-pass filters with programmable gain.

464kB High Density Programmable Switch Matrix



**Computer controlled analog signal
switching replaces tedious manual
patch panels.**

The 464kB is a reliable solid-state switch matrix system that provides computer-controlled connection between 256 inputs and 256 outputs, all in a single mainframe. Save time and reduce errors on test system setup. Download switch configurations from the host computer over the network. Built-in self-test with fault diagnostics.