

SYSTEM 28000 FEATURES

- Mix transducers in a single system
- Manage hundreds of channels and a mix of sensors
- Assure system integrity before performing measurements
- Reduce life-cycle costs
- Upgrade and expand equipment as requirements change
- Count on unsurpassed performance and reliability

SYSTEM FEATURES FOR 28524 CARDS

- 32 channels per 28008 system
- 64 channels per 28016 system
- Graphical User Interface (GUI) for system control
- Ethernet or RS-232C for remote control
- Test input and output monitor busses
- Go/no-go test with diagnostics to be run before performing tests
- Rigorous factory acceptance test for calibration and maintenance

28524 DESCRIPTION

The 28524 is a member of the 28000 family of signal conditioners. It provides conditioning for pulse rate and frequency transducers, giving a voltage output proportional to input frequency or rate. A programmable attenuator allows linear operation with 100 V input levels.

The user may select a limited band of frequencies within the 50 kHz range by programming a low frequency, F_L , and a high frequency, F_H , for each channel. The user may also specify the output voltages corresponding to these frequencies by selecting a low voltage, V_L , and a high voltage, V_H . The same voltage settings are applied to all channels on a card.

The measured frequency is displayed in the GUI and is updated approximately every ten seconds. This read-back feature can be disabled.

To accommodate distorted inputs such as signals with ringing, crossover or harmonic distortion, the 28524 has programmable trigger threshold and trigger hold-off time.

Test inputs, along with the system test bus and monitor bus make the card ready to work with the 28000 Test Subsystem hardware and software to support Go/No-Go and factory acceptance tests.

FREQUENCY-TO-VOLTAGE MODULE FEATURES

- 1 Hz to 50 kHz frequency range
- Up to 100 V input
- 16-bit output voltage resolution
- Test input



28524 PROGRAMMABLE FEATURES

- Input frequency range: F_L , F_H
- Output voltage output range: V_L , V_H
- Low frequency roll-off
- Trigger threshold
- Positive or negative trigger
- Hold-off trigger time
- Prescaler
- Input range

INPUT CHARACTERISTICS

Input Type: DC-coupled, differential
 Input Ranges: 1 V, 10 V, 100 V
 Maximum Input: 100 V, differential + common mode
 Amplitude Range: 10 mV to 100 V for sine wave and square wave
 40 mV pk to 100 Vpk for pulse amplitude, 5 μ S min pulse width

Max. Frequency In: 50 kHz
 Min. Frequency In: 1 Hz
 F_H Settings: 10 Hz to 50 kHz in 1 Hz Steps
 F_L Settings: 0 Hz to ($F_H - 10$ Hz) in 1 Hz Steps
 Note: minimum separation between F_H and F_L setting is 10 Hz

Input Z: 400 k Ω , 1 V and 10 V, differential
 210 k Ω , 100 V range, differential
 110 k Ω , common mode
 Common Mode In: 100 V max.
 CMRR: 70 dB, DC to 50 Hz; 40 dB to 5 kHz
 Input Noise: 300 μ V rms in 600 kHz BW
 Input Connector: 15-pin subminiature D-shell
 Input Wires: HIGH, LOW, SHIELD per channel

28524 TRIGGER

Selectable Trigger Type

Positive or negative edge trigger, user selectable.

The selectable edge trigger allows the user to choose the positive (leading) or negative (trailing) signal edge. Selecting the edge with the sharper transition produces a more stable output. See Figure 1.

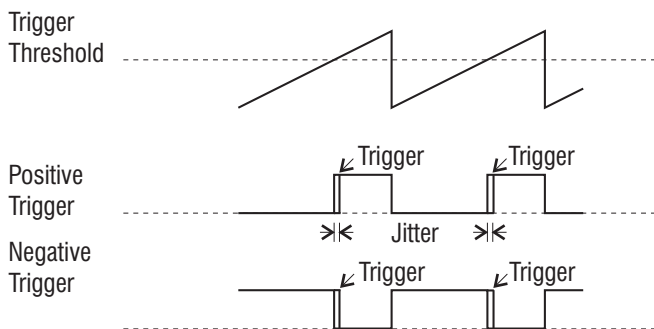

Figure 1 Selectable Trigger

Programmable Trigger Hold Off Period

The programmable trigger hold-off time prevents false triggering on signal edges which cross the trigger threshold voltage but are not representative of the actual input frequency. On each valid edge, the trigger circuit is disabled for a period of time to ignore the false edges. An input signal with ringing could cause false triggering. See Figure 2.

Range: 1 μ S to 1 S in 1 μ S steps

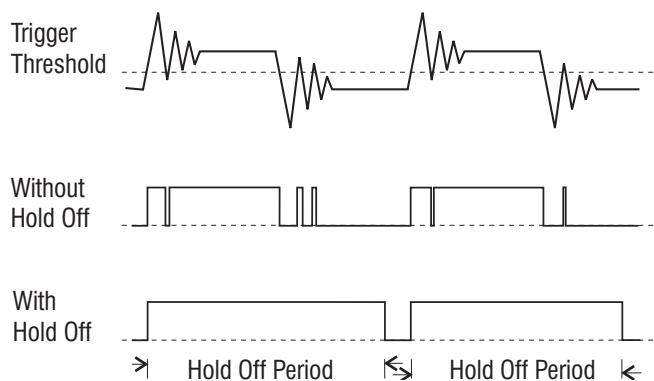

Figure 2 Programmable Trigger Hold Off

TRIGGER (Continued)

Programmable Trigger Threshold

The programmable trigger threshold allows the user to adjust the trigger voltage up or down to avoid distorted portions of the input signal. A signal with crossover distortion could cause false triggering. See Figure 3.

100V range: \pm 100 V in 50 mV steps
 10V range: \pm 10 V in 5 mV steps
 1V range: \pm 1 V in 500 μ V steps

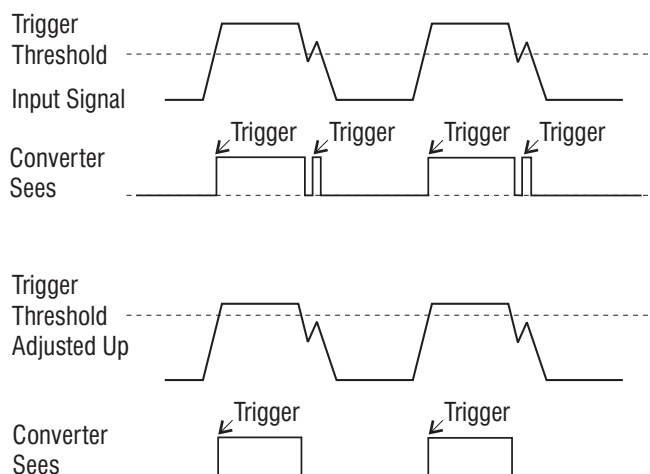

Figure 3 Programmable Trigger Threshold

Auto Trigger

When initiated, the system automatically determines a trigger threshold for a stable input waveform.

PRESCALER

The programmable prescaler divides the input signal by 2 to 255 by counting the specified number of input edges before passing a trigger pulse to the converter circuitry.

In a system where the signal is generated by a transducer sensing gear teeth or flow meter vanes, the signal can be scaled to volts/revolution by dividing the input by the number of teeth or vanes.

28524 INPUT FILTERS

The 28524 provides programmable cascaded high-pass and low-pass filters at the input.

High-Pass Filters: 1-pole; 10 Hz, 100 Hz, or Bypass

Low-Pass Filters: 4-pole Bessel Precision Filters,
A range: 5 Hz to 1.275 kHz in 5 Hz steps (low), 1.5 kHz to 127.5 kHz in 500 Hz steps (high).

F_C is slaved to the upper input frequency setting such that:

$F_C = 5 * F_H$ for $F_H \leq 25.5$ kHz and
 $F_C = 127.5$ kHz for $F_H > 25.5$ kHz.

The low-pass filter can be bypassed.

28524 OUTPUT CHARACTERISTICS

Max. Voltage Out: ± 10 VDC
 V_H Settings: -9 V to 10 V in 0.1 V steps
 V_L Settings: -10 V to $(V_H - 1)$ V in 0.1 V steps

Type: DC coupled, single-ended output with Ground sense

Output Filter Type: 2-pole Bessel
Output Filter F_c 's: 1 Hz, 10 Hz, 100 Hz, Bypass

Z: 50Ω || 100 pF

Voltage

Output Resolution: $(F_H - F_L)/65535$ Hz
Initial Accuracy: ± 2 mV $\pm 0.01\%$ $(V_H - V_L)$ $\pm 0.015\% * \epsilon$ accuracy typical
 ± 5 mV $\pm 0.05\%$ $(V_H - V_L)$ $\pm 0.015\% * \epsilon$ accuracy, max

Where $\epsilon = F_H / (F_H - F_L)$

Drift: $(100$ ppm of setting + $20 \mu\text{V})/^\circ\text{C}$

Noise: $100 \mu\text{V} \sqrt{\text{Hz}}$, 1 MHz BW

Pulse Output: 5 V CMOS, $F_{OUT} = F_{IN}$

28524 OUTPUT CHARACTERISTICS (Cont.)

Freq. Measurement

Accuracy: $\pm 0.03\%$ typical

Freq. Display

Resolution: 1.00 to 999.99 in 0.01 Hz steps
 $1,000.0$ to $9,999.9$ in 0.1 Hz steps
 $10,000$ to $50,000$ in 1 Hz steps

Rear Output Conns: 26-pin D-shell for VDC and pulse out
50-pin D-Shell for VDC

Front Output Conns: 48-pin DIN for pulse outputs

TRANSFER CHARACTERISTICS

VDC Output Update Rate:

$F_{in} > 1$ kHz: 1 to 2 mS
 $F_{in} < 1$ kHz: $1/F_{in}$ S + 1 mS

Settling time to 0.05% of final value:

Output Filter Bypassed: $\approx 125 \mu\text{S}$
Output Filter $F_c = 1$ Hz: 1.2 S
Output Filter $F_c = 10$ Hz: 120 mS
Output Filter $F_c = 100$ Hz: 12 mS

Pulse output: 5 V square wave, $F_{OUT} = F_{IN}$

TEST BUS

A switch at the input of each channel allows the application of a signal for test and calibration. The test bus is used by the Test Subsystem module.

Also, an input can be simulated via GUI control. The user enters a frequency and the 28524 loads the output DAC with the appropriate value taking into account the F_H , F_L , V_H , and V_L set points.

Frequency Entry

Resolution: 1.00 to 999.99 in 0.01 Hz steps
 $1,000.0$ to $9,999.9$ in 0.1 Hz steps
 $10,000$ to $50,000$ in 1 Hz steps

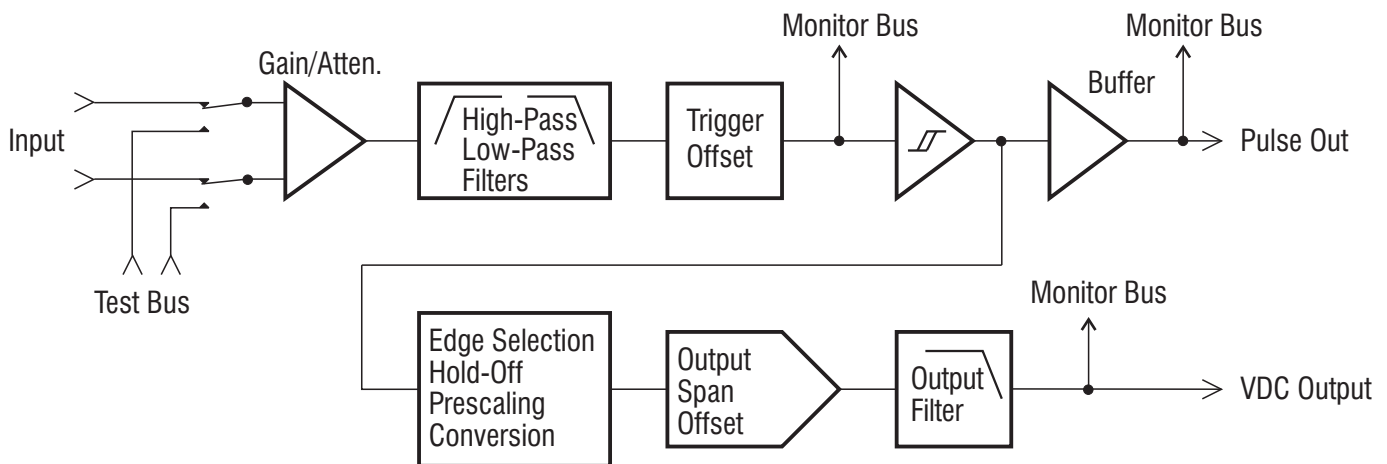

Figure 4 Block Diagram of Typical 28524 Channel

MONITOR BUS

Switches at the trigger level input circuit, conversion output and pulse output allow for connection to the output monitor bus. The output monitor bus is available via BNC at the main-frame front panel. The monitor bus is used by the Test Sub-system module.

CHARACTERISTICS

28524 Card Size: 6.63 x 17.5 x 0.75 inches
Card Weight: 1.3 lbs net, 3 lbs shipping
Temperature: 0^o to 40^o C (operating)
-20^o to 70^o C (storage)



28524 Input and Output Connectors

ACCESSORIES

Mating Connectors

Precision Filters mating connectors accommodate up to 22 AWG wire and are supplied with high quality metal backshells and gold plated screw machined contacts for high reliability connections and long service life.

CONN-IN-15D:

Multipin 15-pin D-shell mating input connector with crimp sockets and metal backshell with strain relief.

CONN-IN-15D-SC:

Multipin 15-pin D-shell mating input connector with solder cup sockets and metal backshell with strain relief.

CONN-OUT-26D-MTL:

High-Density 26-pin D-shell mating output connector with machined solder cup pins and metal backshell with strain relief with large hole.

CONN-OUT-26D-SC-MTL:

High-Density 26-pin D-shell mating output connector with machined solder cup pins and metal backshell with strain relief with large hole.

Output Adapter

28524 cards are fitted with front panel connectors that accept the output adapter modules in order to provide multiple buffered "pulse" outputs. Adapters plug on to the front of the signal conditioner card and are secured to the card by two screws. The adapters provide four additional fully buffered BNC outputs per channel and one 15-pin D-shell output connector.

The BUFF-4BNC/15D Quad output buffer module provides one buffered output per channel on 4 BNC connectors or one 15-pin multipin connector.

BUFF-4CH/(2)15C: Quad output buffer with dual outputs per channel on two 15-pin connectors.

