



Precision 28458 Eight-Channel Conditioner with Balanced Constant Current Excitation

The 28458 is a member of the Precision 28000 family of signal conditioners. It provides conditioning for strain gages or other resistive non-self-generating transducers with 2-wire connections.

The 28458 is equipped with Precision Filters' proprietary balanced differential constant current excitation. This topology is especially useful for reducing pickup from interfering sources as compared with traditional unbalanced current sources. The high visibility, real time gage health monitor circuits continually indicate loop resistance, excitation current, open or shorted gages and provide a real time indication of an "out of spec" condition. The input overload detector reports internal saturation conditions caused by out-of-band signals, which could be masked by the low pass filter, resulting in in-band distortion.



Overview

28000 Analog Signal Conditioning System

The new standard for the world's most discriminating test labs.



The Precision 28000 Signal Conditioning System provides all the flexibility you need to manage your test measurements.

The Precision 28000 makes it easy to manage a test with hundreds of channels and a mix of transducers. Choose charge, IEPE w/TEDS, voltage (filter amplifier), strain, thermocouple, RTD, potentiometer, current, frequency, or other transducers.

The built-in test hardware and software (optional) provide quick go/no-go tests which can be run before each test, and rigorous factory acceptance tests to assure you that the 28000 meets your most stringent requirements for critical applications. It won't be long before these tests earn a permanent place in your maintenance routine. And since they are traceable to NIST, they eliminate the need for off-site calibration.

In every phase of your tests—record keeping, installation, design, set-up, operation, maintenance and upgrading—the Precision 28000 offers ways to help you save time and money over the life of the system.

28000 System Features

- Graphical User Interface (GUI) and Ethernet network interface for system control
- Intelligent gain and system scaling algorithms
- Test input and output monitor busses
- Go/no-go test with diagnostics to be used before tests
- Rigorous factory acceptance test for maintenance
- Field swappable AC power supplies
- Built-in temperature and power supply monitoring with alarms

28458 Applications

- Dynamic strain gage conditioner
- High temperature strain gage conditioner
- Dynamic Hot wire anemometry
- AC Filter/Amplifier

Precision 28458 Features

- Eight channels per card
- 128 channels per 28016-M3 or 28016-M5 mainframe, 64 channels per 28008-M3/M5 mainframe, 32 channels per 28004-M3/M5 mainframe
- AC coupled balanced differential input
- Balanced differential constant current excitation
- Excitation disconnect for voltage/amp operation
- AC current test mode for verifying transducer, cabling and frequency response
- On-the-fly report of measured transducer excitation and resistance
- Transducer open/short indication
- Transducer leakage to ground detection
- 4-pole flat/pulse low-pass filter (LP4FP) with cutoff options from 100 Hz to 100 kHz
- Bypass filter for wideband amplifier operation (-3dB @ 190 kHz)
- Voltage substitution test signals
- Programmable amplifier: x½ to x1024 with 0.05% vernier
- 2° phase matching between any channels
- Pre-filter overload detector to report out-of-band overloads which the filter could mask
- Dual buffered outputs

Precision 28458 Description

28458 Description

The 28458 is a member of the Precision 28000 family of signal conditioners. The 28458 provides eight channels of conditioning for transducers requiring constant current excitation. Up to sixteen 28458 cards may reside in the 28000 system to provide 128 channels per chassis. In addition, the 28458 may be mixed with other conditioners in the 28000 family to meet your unique signal conditioning requirements.

Balanced Constant Current Excitation

The 28458 is equipped with Precision Filters' proprietary balanced differential constant current excitation that is optimized for making dynamic strain measurements on single active strain gages. Balanced constant current excitation provides an accurate means of measuring dynamic strain with a single active strain gage using only a two-wire connection.

Balanced constant current excitation provides a true balanced input for rejection of common-mode signals. Electrostatic pickup is reduced when compared to single-ended constant current excitation or a quarter bridge configuration with remote completion resistors or unbalanced current sources. The balanced current excitation circuit operates properly even under certain common gage fault conditions such as a direct short of the gage to the test model.

Programmable excitation provides 0 to ± 20 mA of constant current with an "excitation off" mode to detect self-induced signals. The excitation current source may be modulated to allow AC current injection into the loop. The frequency and amplitude of the AC current is user controlled. This allows the user to simulate changes in gage resistance in the loop and provides direct AC input stimulation to the signal conditioner for end-to-end system calibration.

Transducer Health Monitor

Large changes in sensor impedance or sensor excitation can indicate that data from a particular sensor is no longer meaningful. The unique transducer health monitor circuits of the 28458 allow for continuous monitoring of critical sensor health data without disruption of the test. Sensor excitation and loop resistance is measured and reported. Measured values are compared to user specified limits and flagged if out of tolerance. In addition, the 28458 monitors gage bias levels in order to detect excitation current leakage conditions in the external current loop and to detect gage open and short conditions. Transducer open, short and leakage status are periodically monitored and reported.

Input Stage

The 28458 input stages have balanced differential inputs with high common-mode rejection. The AC coupled input is useful for dynamic applications where the DC bias on the transducer is removed to allow amplification of the smaller gage fluctuations. The excitation supply may be disconnected from the amplifier input to allow the 28458 to be used as a voltage filter/amplifier. The input stage may be shorted under program control to verify signal conditioner channel noise. A switch at the input stage is provided to connect the amplifier to the 28000 system test bus (voltage substitution). The test bus is used to inject signals for performance verification.

Amplifier and Filter

Programmable pre- and post-filter amplifiers provide an overall gain of 1024. Gain is distributed both before and after the filter to provide protection from large out-of-band energy or transients that could cause clipping before the filter, distorting the data. Overload detectors alert the user to over-voltage conditions at the filter input.

The 28458 contains a LP4FP 4-pole low-pass filter with five programmable cutoffs and programmable "flat" or "pulse" mode characteristics. The "flat" mode provides pass-band characteristics nearly identical to a 4-pole Butterworth filter while providing improved stop-band rejection. This mode is a good choice for applications such as spectral analysis.

The "pulse" mode provides a pass-band similar to a 4-pole Bessel filter while providing better stop-band rejection. The "pulse" mode is ideal for time domain applications including transient (shock) measurements and time domain waveform analysis. The filter may be bypassed under program control to provide a 3-pole Butterworth response with 190 kHz bandwidth.

Two fully buffered outputs are provided for each channel that may be used to drive long output cable runs to different destinations without causing noise or ground loops that plague TEE'D outputs. Also, a short on one buffered output will not affect the other output.

28458 Programmable Features

- Excitation level (0, 5, 10, 15, 20 mA)
- Excitation disconnect
- Input interface (2-wire plus shield)
- Loop resistance detection thresholds
- Transducer open/short thresholds
- Test Modes: Amp Short, Excitation Off, AC Current, Test Bus
- Output monitor
- Gain ($\times 1/2$ to $\times 1024$ with 0.05% resolution)
- Cutoff frequency:
 - FX02: 300 Hz, 1kHz, 10 kHz, 30 kHz
 - FX03: 10 kHz, 20 kHz, 40 kHz, 80 kHz, 100 kHz
- Wide-band (190 kHz) or filtered operation
- Shield (open, grounded, or driven)

28458 Graphical User Interface Display

All programmable features in addition to:

- On-the-fly excitation monitor
- On-the-fly sensor resistance monitor with pass/fail status
- Sensor open or short indication
- Input wiring
- Transducer sensitivity
- System scaling in engineering units
- Overload status
- Intelligent gain algorithm
- Group control

28458 Filter Characteristics

The 28458 Card has two filter characteristics available for low-pass filtering.

Flat/Pulse Low-Pass Filters

The LP4FP 4-pole flat/pulse low-pass filter provides the user a filter for either the time or frequency domain. The selection of flat (LP4F) or pulse (LP4P) mode may be selected under program control.

Flat Mode Low-Pass Filters

Precision LP4F "flat" mode characteristic is equivalent to a 4-pole Butterworth with better stop-band rejection.

The LP4F can be used as an anti-aliasing filter and for applications such as spectral analysis.

Pulse Mode Low-Pass Filters

For the time domain, there are the LP4P "pulse" mode low-pass filters. These filters have excellent transient response and phase linearity making them ideal filters for time domain applications including transient (shock) measurements and time domain waveform analysis with stop-band rejection superior to a Bessel filter counterpart.

LP4F and LP4P Amplitude Response

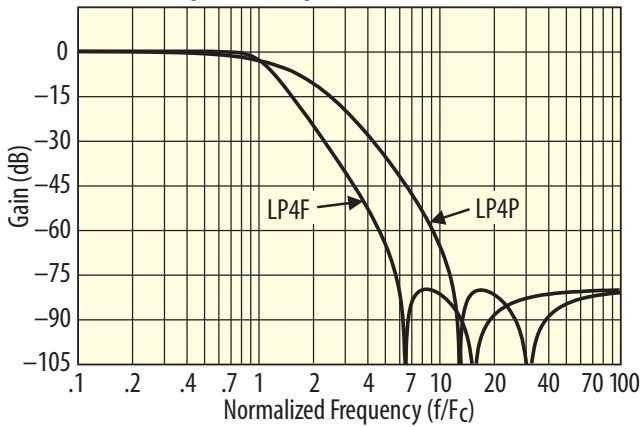

LP4F vs Butterworth Passband Response

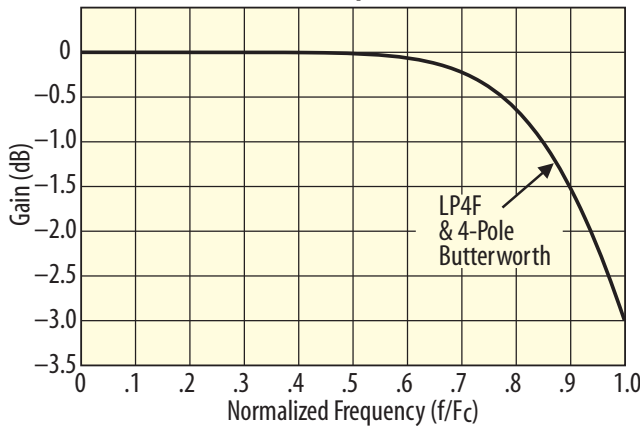

LP4F vs Butterworth Amplitude Response

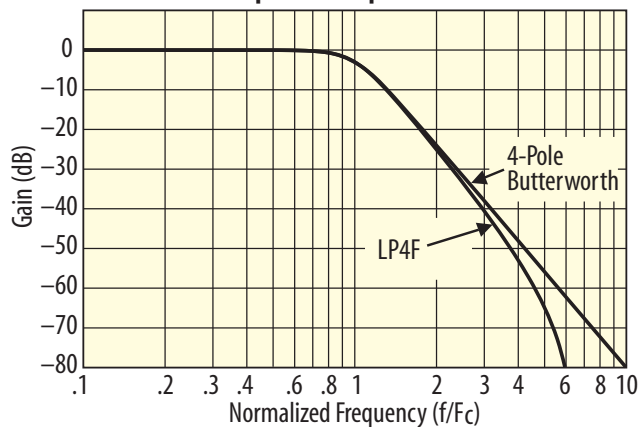

LP4P vs Bessel Passband Response

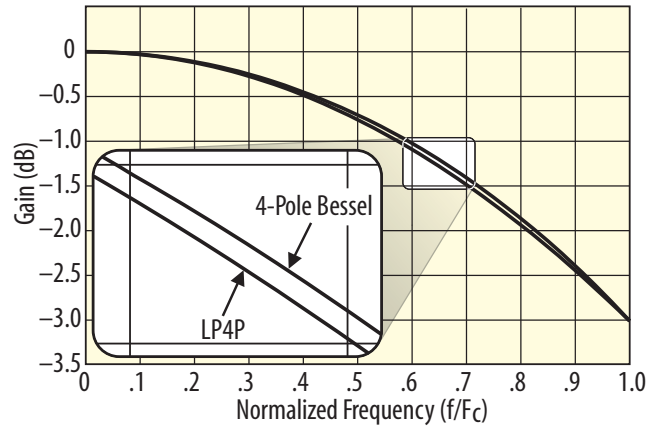

LP4P vs Bessel Step Response

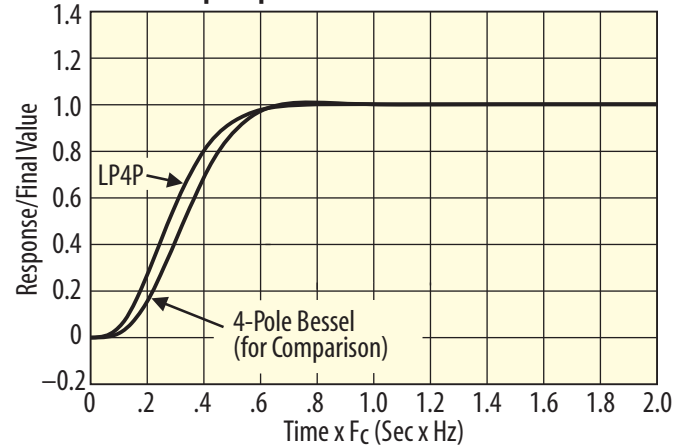

28458 Details and Specifications

28458 Conditioner Cards

The detailed description and specifications for the 28458 are organized as follows in the sections below:

- Excitation Supply
- Mute Mode
- Transducer Health Monitor
- Input Characteristics
- Amplifier Characteristics
- Test Modes
- Output Characteristics
- Filter Type Characteristics
- General Characteristics
- Connectors
- Accessories
- Ordering Information

28458 Excitation Supply

- Type:**
Balanced differential constant current excitation
- Total Gage Voltage:**
 $24 - I * 400$
- Maximum Output:**
20 mA
- Steps:**
0, 5, 10, 15, 20 mA
- Input Impedance:**
100 k Ω nominal per side
- CMRR (DC to 1 kHz):**
80 dB for 120 Ω gage
70 dB for 350 Ω gage
60 dB for 1 k Ω gage
- Initial Accuracy:**
 $5 \mu\text{A} + 0.1\%$ of setting
- Temperature Drift:**
 $70 \text{ nA} + 0.003\%$ of setting per $^{\circ}\text{C}$
- Noise:**
 $140 \text{ pA}/\sqrt{\text{Hz}}$ at 1 kHz
- Bandwidth:**
 $\pm 0.05 \text{ dB}$ to 40 kHz (RGAGE < 1 k Ω)

28458 Mute Mode

In harsh test environments, a sensor or input cable can become faulty or intermittent during a critical test. With high gain signal conditioning, this can be troublesome if large signal swings on input or output cabling cross couple to other channels. The 28458 mute control places the channel in the quietest operational state to minimize system noise in the event of a failed sensor. The Mute Mode is also useful to terminate unused channels in a safe and quiet state.

28458 Transducer Health Monitor

Sensor Excitation Monitor: Transducer excitation current is monitored and reported to the user on-the-fly. Measured excitation is compared to factory set tolerance and GUI indicators report if out of tolerance.

Sensor Resistance Monitor: Transducer resistance is monitored on-the-fly and compared to user defined limits. GUI indicators report if sensor resistance is out of user tolerance.

Sensor Open/Short Monitor: Transducer open or short condition is monitored and reported to the user via GUI indicators.

Sensor Leakage Monitor: Sensor leakage resistance to ground is measured and reported.

28458 Transducer Interface

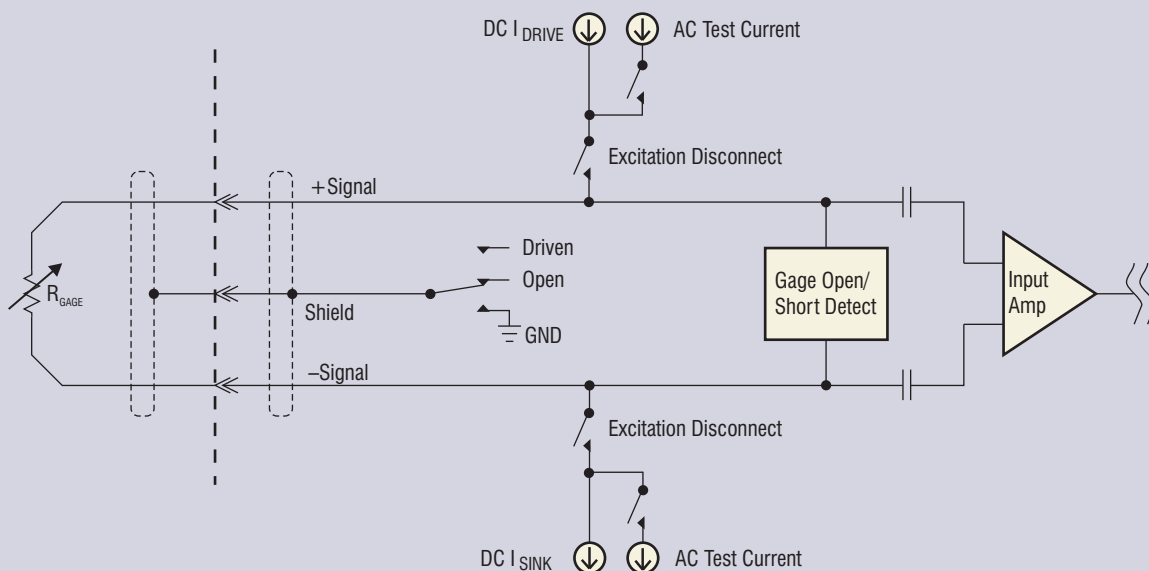

28458 Details and Specifications

28458 Input Characteristics

Type:

Balanced Differential w/AC input coupling

Input Impedance:

10 MOhm //100pF per side

Max Level:

(AC + DC + Common Mode)

± 10 Vpk for $f \leq 100$ kHz

± 10 Vpk x (100 kHz/f) for $f > 100$ kHz

Input Protection:

± 30 V continuous with power on; ± 100

Vpk transient (1 ms pulse, 10% duty cycle)

Noise:

15 nV per rt. Hz at 1 kHz and

pre-filter gain > 8 , typical

AC Coupling Frequency:

1 Hz (-3.01 dB)

CMRR:

90 dB, 60 Hz and input gain $> x8$

Shield:

Programmable (Open, Driven, or Grounded)

28458 Amplifier Characteristics

Pre-filter Gain:

$x1$ to $x64$ in binary steps with overload detection (10.5 Vpk threshold)

Post-filter Gain:

$x\frac{1}{2}$ to 16 in 0.05% of setting

Overall Gain:

$x\frac{1}{2}$ to $x1024$ vernier adjustment of 0.05% of setting

Distortion:

0.1% re Fullscale

Frequency Response (Bypass Mode):

6 Hz to 40 kHz, 0 dB ± 0.1 dB

-3.01 dB Bandwidth:

190 kHz, typical

Bypass (Unfiltered)

High Frequency Roll-off:

18 dB/octave

28458 Channel Block Diagram

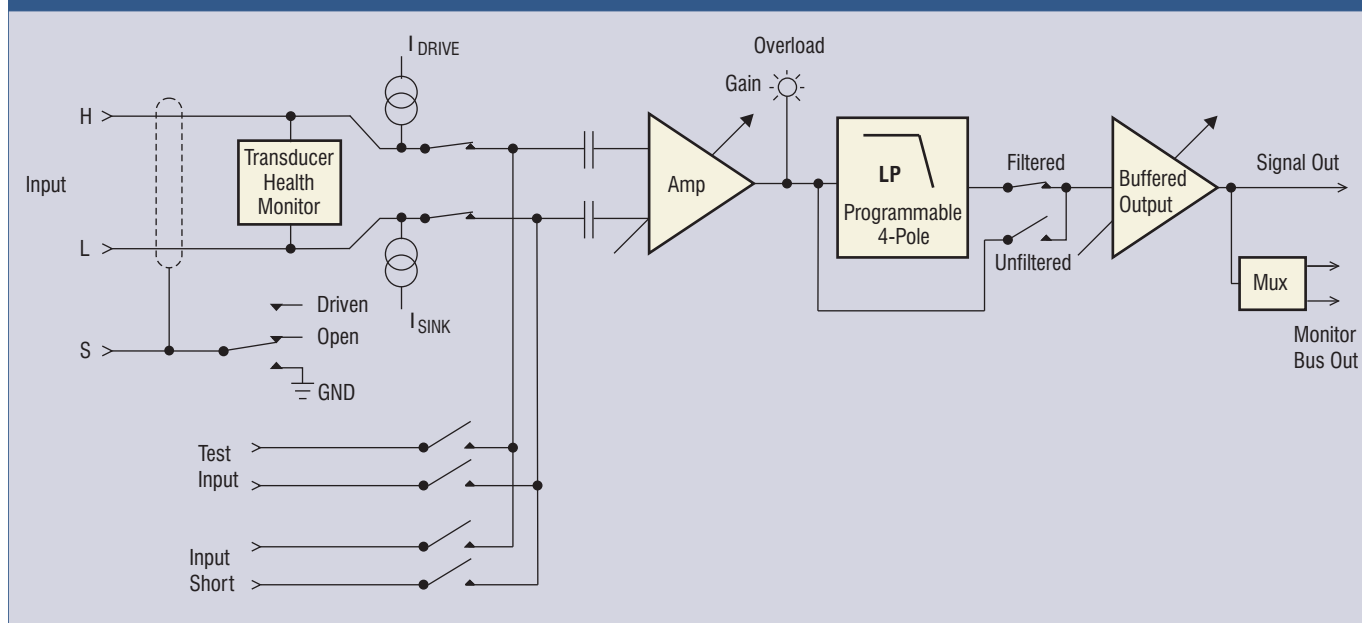

28458 Details and Specifications

28458 Test Modes

Run:

The normal operating configuration of the channel

AC Current:

A small AC current is injected into the current loop to evaluate end-to-end system frequency response. The AC current is generated from a voltage on the test bus. Frequency and amplitude of the AC current may be controlled by changing the frequency and amplitude of the test bus signal.

AC Current Level:

0.1 mA PK ($\pm 0.2\%$) per 1 V PK test bus signal 1 Hz to 50 kHz

I Zero:

The excitation current is set to zero (open circuit).

Short:

A switch at the amplifier input is used to ground the input stage for measurement of noise.

Test Bus:

Test input allows for injection of a test signal. An external test signal or the 28000-?-TEST Test Subsystem may be connected at the rear panel. Refer to the 28000-?-TEST Test Subsystem specification for more information.

28458 Output Characteristics

Type:

Two independently buffered single ended outputs
Z: $10\ \Omega$ shunted by 100 pF

Max Output:

$\pm 10\ \text{Vpk}$, $\pm 5\ \text{mA pk}$

Noise:

$6\ \mu\text{Vrms RTI} + 60\ \mu\text{Vrms RTO}$, typical
3 Hz to 100 kHz

Crosstalk:

-80 dB, DC to 25 kHz between channels
with the same configuration and programmed settings

Output Monitor (Standard)

A switch located at the output of each channel allows for multiplexed connection to the mainframe output monitor bus. The output monitor bus is available at a connector located at the rear of the mainframe. The monitor function is used by the Test Subsystem or is available to the user for viewing channel output.

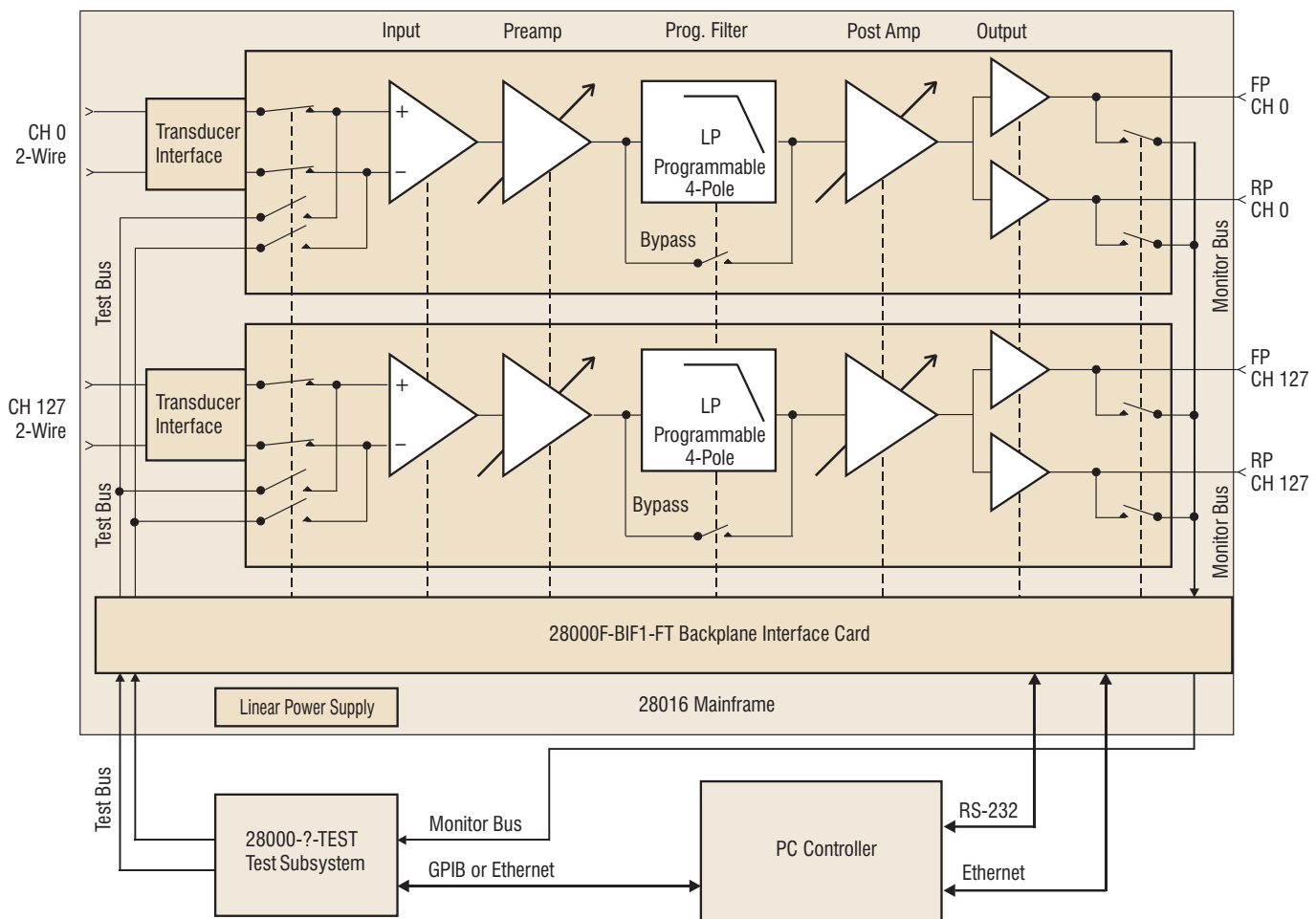

System Block Diagram

28458 Details and Specifications

28458 Filter Type Characteristics

LP4FP (4-pole low-pass)

4-pole, 4-zero low-pass filter.
Programmable for maximally flat pass-band (LP4F) or linear phase with optimized pulse response (LP4P).

Cutoff Frequencies:

FX02:
300 Hz, 1 kHz, 3 kHz, 10 kHz, 30 kHz
FX03:
10 kHz, 20 kHz, 40 kHz, 80 kHz, 100 kHz

LP4F and LP4P:

Amplitude Accuracy:
±0.1 dB max, DC to 0.8 Fc
Amplitude Match:
±0.1 dB max, DC to 0.8 Fc
±0.2 dB max, 0.8 Fc to Fc
Phase Match:
±1° max, DC to 0.8 Fc
±2° max, 0.8 Fc to Fc

Specification	LP4F Maximally Flat Low-Pass Filter	LP4P Constant Time Delay Low-Pass Filter
Cutoff Frequency Amplitude	-3.01 dB	-3.01 dB
DC Gain	0.00 dB	0.00 dB
Pass-Band Ripple	0.00 dB	0.00 dB
Stop-Band Frequency (-80 dB)	5.9465 Fc	11.863 Fc
Cutoff Frequency Phase	-180.0 deg	-101.5 deg
Phase Distortion (DC to Fc)	< 31.8 deg	< 3.7 deg
Zero Frequency Group Delay	0.4117/Fc	0.2920/Fc
Percent Overshoot	11.1%	0.5%
1% Settling Time	1.65/Fc	0.66/Fc
0.1% Settling Time	2.72/Fc	0.77/Fc
-0.1 dB Frequency	0.6348 Fc	0.1816 Fc
-1 dB Frequency	0.8487 Fc	0.5742 Fc
-2 dB Frequency	0.9370 Fc	0.8129 Fc
-3.01 dB Frequency	1.0000 Fc	1.0000 Fc
-20 dB Frequency	1.7412 Fc	3.0248 Fc
-40 dB Frequency	2.9555 Fc	5.6932 Fc
-60 dB Frequency	4.5986 Fc	9.0980 Fc

28458 Card General Characteristics

28458 Card Size:

6.6 x 17.5 x 0.75 inches

Card Weight:

1.5 lb. Net

Temperature:

0° to 40° C (operating)

-20° to 70° C (storage)

Connectors

The input connectors are integral to the 28458 card. Cutouts on the 28000 frames allow the 28458 input and output connectors to pass through the backplane and mate directly with the I/O cables. Two 26-pin high-density D connectors are utilized, one for the 8 inputs and another for the 8 outputs. Connectors have high quality machined gold plated pins/sockets. A second set of outputs are available on a 26-pin high-density D connector at the front panel of the card. Three wires per output are provided to accommodate twisted/shielded cables.

The 28458 has a DE9 9-pin D connector on the front panel that is utilized by the 28000 Test Subsystem and the CB-28458-TEST test cables to perform Factory Acceptance Tests on the 28458 card.

Accessories

Mating Connectors

Precision Filters mating connectors accommodate up to 22-AWG wire and are supplied with high quality metal backshells and gold plated screw machined contacts for high reliability connections and long service life.

CONN-IN-26D-MTL: High-Density 26-pin D-shell mating input connector with machined crimp pins and metal backshell with strain relief.

CONN-IN-26D-SC-MTL: High-Density 26-pin D-shell mating input connector with machined solder cup pins and metal backshell with strain relief.

CONN-OUT-26D-MTL: High-Density 26-pin D-shell mating output connector with machined crimp pins and metal backshell with strain relief.

CONN-OUT-26D-SC-MTL: High-Density 26-pin D-shell mating output connector with machined solder cup pins and metal backshell with strain relief.

Test Cables:

CB-28458-TEST: DE9 to 34410A terminal block cable for Factory Acceptance Test (FAT).

CB-REF-C: Reference cable for FAT match tests on M3 chassis.

CB-HD26P-REF-C: Reference cable for FAT match tests on M5 chassis.

28458 Card Model Number

The 28458 card model number describes the configuration of the eight channels on the card. The model number identifies the filter type of the low-pass and cutoff frequencies.

28458-Cutoff Frequencies-Filter Type

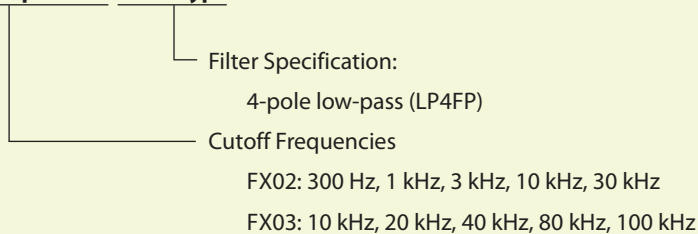

Precision Product Solutions

For over 30 years Precision Filters has been a global provider of instrumentation for test measurements. You can rely on a single source for signal conditioning and switching—a *complete range of instrumentation*—products optimized to work together to provide high performance at reasonable cost.

Precision Products

Precision PF-1UA-FA Multi-Channel Programmable Filter/Amplifier System



Exceptional desktop performance at low cost.

Ideal for conditioning low-level voltage inputs in front of high-resolution digital data acquisition systems. Fully programmable 8-channel and 16-channel configurations are available, both offering a choice of either 4- or 8-pole filters with programmable gain.

464kB High Density Programmable Switch Matrix



Computer controlled analog signal switching replaces tedious manual patch panels.

The 464kB is a reliable solid-state switch matrix system that provides computer-controlled connection between 256 inputs and 256 outputs, all in a single mainframe. Save time and reduce errors on test system setup. Download switch configurations from the host computer over the network. Built-in self-test with fault diagnostics.