

28454A QUAD-CHANNEL CONDITIONER BALANCED CURRENT EXCITATION

Constant Current Excitation; 700 kHz Bandwidth

 PRECISION
FILTERS, INC.



SYSTEM 28000 FEATURES

- Graphical User Interface (GUI) for system control
- Intelligent gain and system scaling algorithms
- Test input and output monitor busses
- Go/no-go test with diagnostics to be used before tests
- Rigorous factory acceptance test for maintenance
- Field swappable AC power supplies
- Built-in temperature and power supply monitoring with alarms

28000 SIGNAL CONDITIONER SYSTEM

The Precision 28000 signal conditioning system provides all the flexibility you need to manage your test measurements.

The Precision 28000 makes it easy to manage a test with hundreds of channels and a mix of transducers. Choose charge, IEPE w/TEDS, voltage (filter amplifier), strain, thermocouple, RTD, potentiometer, current, frequency, or other transducers.

The built-in test hardware and software (optional) provide quick go/no-go tests which can be run before each test, and rigorous factory acceptance tests to assure you that the 28000 meets your most stringent requirements for critical applications. It won't be long before these tests earn a permanent place in your maintenance routine. And since they are traceable to NIST, they eliminate the need for off-site calibration.

In every phase of your tests—record keeping, installation, design, set-up, operation, maintenance and upgrading—the Precision 28000 offers ways to help you save time and money over the life of the system.

PRECISION 28454A APPLICATIONS

- Static or dynamic strain gage conditioner
- High temperature strain gage conditioner
- Full bridge conditioner
- RTD conditioner
- Hot wire anemometry
- Low level AC or DC amplifier (<1 mV to 10 V inputs)
- Anti-aliasing filter/amplifier

PRECISION 28454A FEATURES

- 4 channels per card, 64 channels per 28016-M3 chassis or 32 channels per 28008-M3 chassis
- Balanced differential constant current source with 20 V compliance
- Programmable AC or DC coupled input
- Up to 200 kHz “filtered” bandwidth or 700 kHz “wide-band” bandwidth
- 2- or 4-wire input plus shield per channel
- Manual or automatic zero suppress
- Sensor open and short detection
- Excitation current monitor
- Voltage substitution test signals
- AC current test mode for verifying transducer, cabling and frequency response
- Programmable amplifier: x1/16 to x8,192 with 0.05% vernier
- 4 or 8-pole low-pass filter with bypass (wide-band)
- 2° phase matching between any channels
- Overload detection
- Precise digital calibration
- Auxiliary front panel output connection to support the use of custom output modules



28454A DESCRIPTION

The 28454A is a member of the Precision 28000 family of signal conditioners. It provides conditioning for strain gages, RTDs, or other resistive non-self-generating transducers with 2-wire or 4-wire (Kelvin) connections.

The 28454A is equipped with Precision Filters' proprietary balanced differential constant current excitation. This topology is especially useful for reducing pickup from interfering sources as compared with traditional unbalanced current sources. The gage health monitor circuits indicate open or shorted gages and the input overload detector reports overloads by out-of-band signals which could cause in-band distortion.

Balanced Constant Current Excitation

Balanced constant current excitation provides a true balanced input for rejection of common-mode signals. Using a proprietary constant current source, the 28454A is able to deliver accurate excitation to the gage. Programmable excitation provides 0 to ± 25.5 mA of constant current with an "excitation off" mode to detect self-induced signals. Gage open/short detection is also provided.

For dynamic strain conditioning applications, the 28454A can provide accurate measurements with only two wires by AC coupling the input. For best AC or DC measurements (required for RTD type transducers), the 28454A provides a 4-wire Kelvin connection for remote sense.

Suppression of the gage DC operating point is performed automatically using the zero suppress feature of the 28454A. Zero suppress allows the use of more gain to emphasize small gage fluctuations. Zero suppress also provides the user with an accurate means to balance a full bridge.

Excitation current flows through an accurate sense resistor in the current loop allowing for direct monitoring of the excitation current. The current source output may be modulated to allow AC current injection in the loop. The frequency and amplitude of the AC current is user controlled. This allows the user to simulate changes in gage resistance in the loop and provides direct AC input stimulation to the signal conditioner for end-to-end system calibration.

Input Stage

The 28454A input stage provides 80 dB of common-mode rejection and may be either AC or DC coupled. AC coupling is useful for dynamic applications where the DC bias on the transducer that can limit dynamic range can be coupled out of the signal. With the input DC coupled, low drift and ultra low noise (< -163 dBV/ $\sqrt{\text{Hz}}$) is provided by the 28454A input stage. The input stage may be shorted to verify signal conditioner channel noise and DC offsets.

A switch at the input stage is provided to connect the amplifier to the 28000 system test bus. The test bus is used to inject signals for performance verification. In addition, both drive and sink current levels may be monitored separately making it possible to detect excitation current leakage conditions in the external current loop.

Amplifier and Filter

Programmable pre- and post-filter amplifiers provide an overall gain of 8192. Gain is distributed both before and after the filter to provide protection from large out-of-band energy or transients that could cause clipping before the filter, distorting the data. The Gain Wizard in the GUI allows the user to set a gain reserve and then apportions the gain between the input and output. This provides input gain for best noise performance yet conforms to the limitations of the user's worst case estimate of out-of-band or transient signals. Overload detectors alert the user to over-voltage conditions. A fully buffered output having over 20 mA of drive capability may be used to drive long output cable runs.

The 28454A contains a 4 or 8-pole low-pass filter with cutoffs programmable from 1 Hz to 204.6 kHz and programmable "flat" or "pulse" mode. The "flat" mode provides pass-band characteristics nearly identical to a Butterworth filter while providing a much sharper roll-off. This mode is a good choice for applications such as spectral analysis. The "pulse" mode has time domain response similar to the Bessel filter yet provides superior amplitude response characteristics. The "pulse" mode is ideal for time domain applications including transient (shock) measurements and time domain waveform analysis.

28454A PROGRAMMABLE FEATURES

- Excitation level (0 to 25.5 mA in 50 μ A steps)
- Input interface (2-wire or 4-wire)
- Automatic zero suppress
- AC/DC coupling
- Input short detection threshold
- Test Modes: Amp Short, Excitation Off, Voltage Substitution, Excitation Drive Current Monitor, Excitation Sink Current Monitor, AC Current Inject
- Output Monitor
- Gain (x1/16 to x8192 with 0.05% resolution)
- Cutoff frequency: 1 Hz to 102.3 kHz, pulse mode
2 Hz to 204.6 kHz, flat mode
- Wide-band (700 kHz) or filtered operation
- Shield (open or grounded)

GRAPHICAL USER INTERFACE DISPLAY

All programmable features in addition to:

- Configuration readback
- Auto-suppress status
- Input wiring
- Transducer sensitivity
- System scaling in engineering units
- Overload, input short and input open status
- Intelligent gain algorithm
- Filter Wizard
- Group control

28454A CONDITIONER CARDS

The detailed description and specifications for the 28454A card are organized as follows in the sections below.

- Card Model Number
- Input Wiring
- Excitation Supply
- Input Characteristics
- Amplifier Characteristics
- Test Modes
- Filter Type Characteristics
- Output Characteristics
- General Characteristics
- Ordering Information
- Accessories

28454A CARD MODEL NUMBER

The 28454A card model number describes the configuration of the four channels on the card. The model number identifies the filter characteristic, or filter type, of the low-pass filters.

28454A-Filter Type

LP4FP (4-pole low-pass)
LP8FP (8-pole low-pass)

28454A INPUT WIRING

Input Connector: 26-pin D-shell (2 ea.)

Input Wiring: I DRIVE (1)
I SINK (1)
 \pm SIGNAL (2)
Shield (1)

28454A EXCITATION SUPPLY

| | | | |
|---------------------|--|-----------------------|--|
| Type: | Balanced differential constant current excitation | Exc. Current Monitor: | Loop Drive and Sink currents may be monitored through precision 100 Ω sense resistors. When I Drive or I Sink test modes are invoked, the DC voltage across the 100 Ω resistor is measured by the differential amplifier input. The DC voltage at channel output is proportional to measured loop current. |
| Total Gage Voltage: | 24 – I * 600 | Sense Resistor | |
| Maximum Output: | 25.55 mA | Accuracy: | ±0.05%, 10 ppm/°C |
| Steps: | 0 to 25.55 mA in 50 μA steps | Output Sensitivity: | (0.1 V/mA of exc. current) * FS _{OUT} /10V FS _{OUT} = Programmed full-scale output voltage |
| Input Impedance: | 100 kΩ nominal per side | | |
| CMRR (DC to 1 kHz): | 80 dB for 120Ω gage 70 dB for 350Ω gage 60 dB for 1kΩ gage | | |
| Initial Accuracy: | 5 μA + 0.05% of setting | | |
| Temp. Drift: | 30 nA + 0.0024% of setting per °C | | |
| Noise: | 65 pA/√Hz at 1 kHz | | |
| Bandwidth: | ±0.05 dB to 50 kHz (R _{GAGE} < 1 kHz) | | |

28454A Transducer Interface

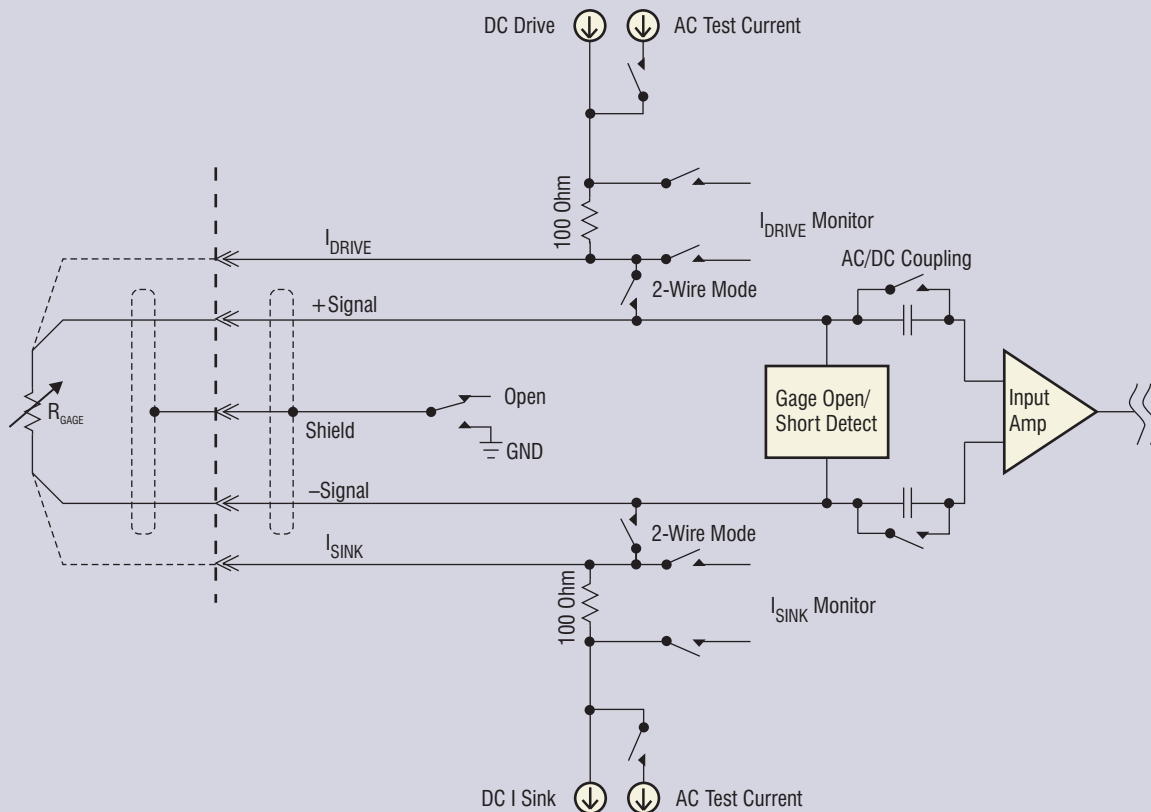

28454A Transducer Interface

28454A INPUT CHARACTERISTICS

Common Mode V: ± 10 V operating

CMRR: 110 dB max, 120 dB typical, DC to 60 Hz, with input gain of x8 or greater

Input Protection: ± 50 V continuous
 ± 100 Vpk transient (1 ms pulse, 10% duty cycle)

Input Impedance: 10 M Ω //100 pF per side
 20 M Ω //50 pF differential
 100 M Ω //200 pF common mode

Max Level: ± 10 Vpk for $f \leq 200$ kHz;
 ± 10 Vpk (200 kHz/f) for $f > 200$ kHz

Offset Drift: 1 $\mu\text{V}/^\circ\text{C}$, typical

Noise: 7 nV/ $\sqrt{\text{Hz}}$ RTI at 1 kHz and gain $> \times 64$

Shield: Prog. (open or grounded)

Transducer Interface:

Programmable 2- or 4-wire interface to the active gage

Open/Short Detect:

Gage open and short detection. The short detection threshold (in ohms) is programmable.

Auto Zero Suppress: A programmable DC offset derived from a precision 10 V reference is injected at the channel input stage to suppress the gage DC operating voltage. Manual or automatic suppression modes are supported.

Ranges: -159.92 mV to $+160$ mV
 in 78 μV steps

-1.2794 V to $+1.28$ V
 in 625 μV steps

-10.235 V to $+10.24$ V
 in 5 mV steps

Accuracy: 0.25% of setting $+5$ mV

Auto Suppress Time: Less than 15 seconds per system of 64 channels

Prog. AC/DC Input Coupling:

Impedance: (0.1 μF & 10 M Ω)/100 pF per side
 (0.159 Hz)

CMRR: 90 dB, 60 Hz and input gain of x8 or greater

28454A Channel Block Diagram

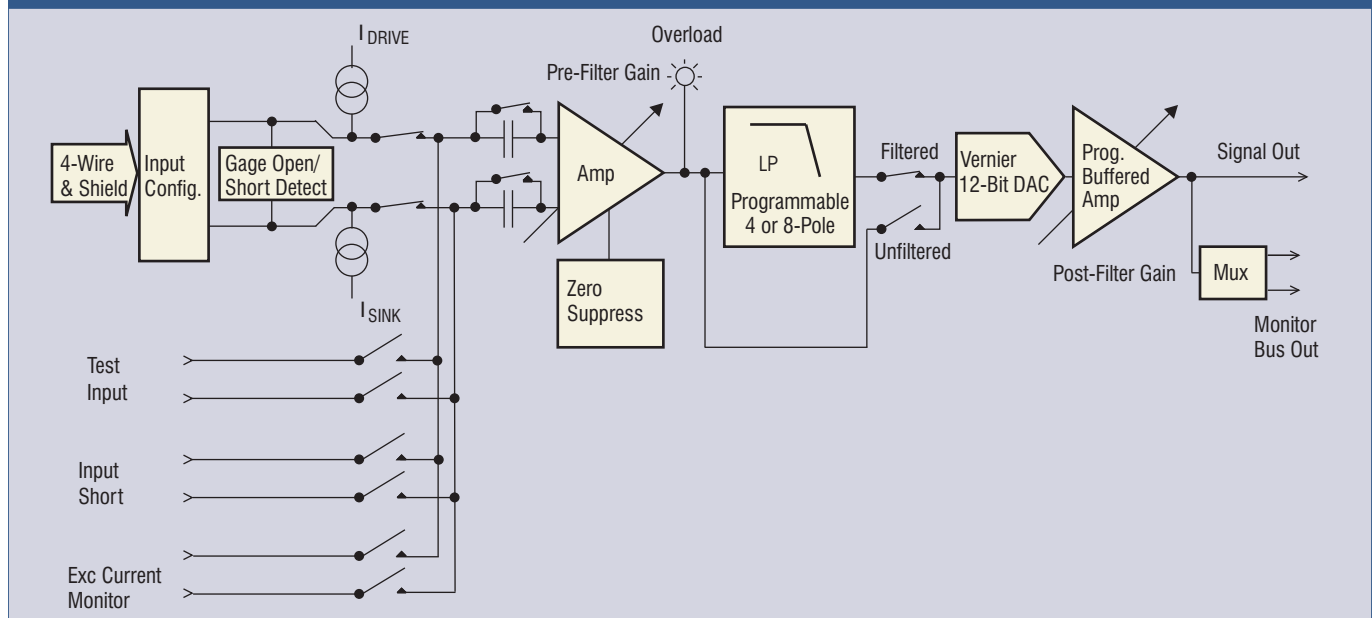

28454A Channel Block Diagram

28454A AMPLIFIER CHARACTERISTICS

Pre-filter Gain: x1 to x512 in binary steps with over-load detection (10.5 Vpk threshold)

Post-filter Gain: x1/16 to x16 in binary steps with vernier adjustment of 0.05% of setting

Calibration: DC Gain is automatically adjusted to better than 0.1% at any setting at user's command.

DC Accuracy: 0.1% after auto-adjust at any gain setting

Stability: $\pm 0.02\%$ for 6 months

Temp Coef.: $\pm 0.004\%/^{\circ}\text{C}$

DC Linearity: $\pm 0.005\%$ re Fullscale, relative to the best straight line

Freq. Response: DC to 100 kHz, 0 dB ± 0.1 dB
200 kHz, 0 dB ± 0.15 dB

-3.01 dB Bandwidth: 700 kHz, typical

High Freq. Rolloff: 18 dB/octave

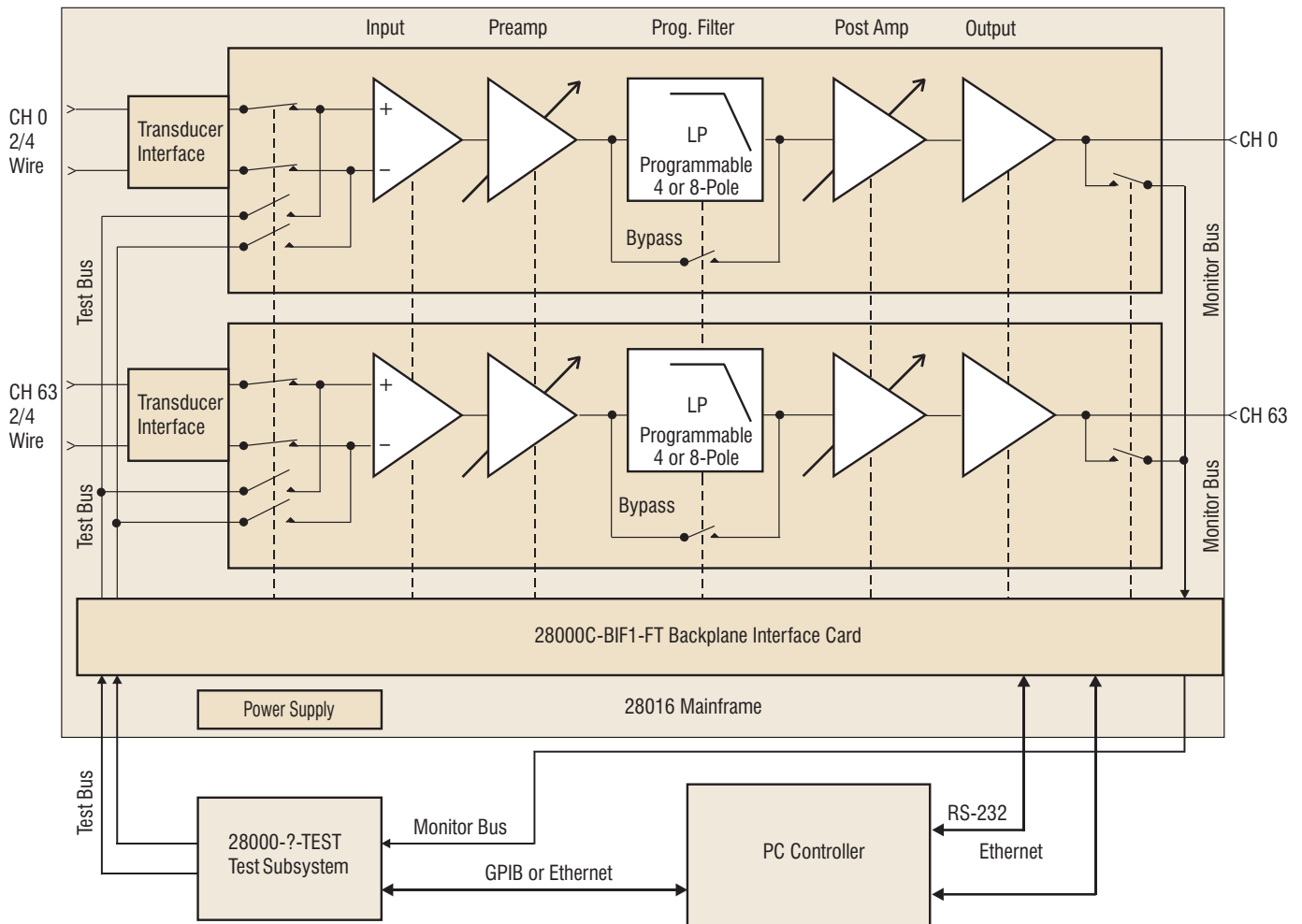

System Block Diagram

28454A TEST MODES

AC Current Inject: A small AC current is injected into the current loop to evaluate end-to-end system frequency response. The AC current is generated from a voltage on the test bus. Frequency and amplitude of the AC current may be controlled by changing the frequency and amplitude of the test bus signal.

AC Current Ampl.: $100 \mu\text{A} \pm 0.2\%$ per volt of test bus signal

I Drive: The excitation drive current is measured and verified by connecting the input amplifier to a precision sense resistor (100Ω , 0.05%, 10 ppm/C).

I Sink: The excitation sink current is measured and verified by connecting the input amplifier to a precision sense resistor (100Ω , 0.05%, 10 ppm/C).

I Zero: The excitation current is set to zero (open circuit).

Short: A switch at the amplifier input is used to ground the input stage for measurement of noise and DC offset.

Test Bus: Test input allows for injection of a test signal. An external test signal or the 28000-?-TEST Test Subsystem may be connected at the rear panel. Refer to the 28000-?-TEST Test Subsystem specification for more information.

Loop Resistance: Excitation is set to 1 mA with unity amplifier gain to evaluate the resistance of the current loop.



28016 Mainframe with 28454A and 28104A Cards



28008 Mainframe with 28454A and 28104A Cards

28454A FILTER CHARACTERISTICS

Option LP4FP:

4-pole, 4-zero low-pass filter.
Programmable for maximally flat pass-band (LP4F) or linear phase with optimized pulse response (LP4P).

Option LP8FP:

8-pole, 8-zero low-pass filter.
Programmable for maximally flat pass-band (LP8F) or linear phase with optimized pulse response (LP8P).

Custom Filters:

Other filter characteristics and cutoff frequencies are available including Butterworth and Bessel types. Please consult with factory for more information.

Cutoff Frequencies:

Flat Mode (LP4F, LP8F, HP4F):

2 Hz to 2.046 kHz in 2 Hz steps

2.2 kHz to 204.6 kHz in 200 Hz steps

Pulse Mode (LP4P, LP8P):

1 Hz to 1.023 kHz in 1 Hz steps

1.1 kHz to 102.3 kHz in 100 Hz steps

LP4F, LP4P, LP8F, LP8P:

Amplitude Accuracy: ± 0.1 dB max, DC to 0.8 Fc
 ± 0.2 dB max, 0.8 Fc to Fc

Amplitude Match: ± 0.1 dB max, DC to 0.8 Fc
 ± 0.2 dB max, 0.8 Fc to Fc

Phase Match: $\pm 1^\circ$ max, DC to 0.8 Fc
 $\pm 2^\circ$ max, 0.8 Fc to Fc

| Specification | LP4F Maximally Flat Low-Pass Filter | LP4P Constant Time Delay Low-Pass Filter | LP8F Maximally Flat Low-Pass Filter | LP8P Constant Time Delay Low-Pass Filter |
|-----------------------------|--|--|--|--|
| Cutoff Frequency Amplitude | -3.01 dB | -3.01 dB | -3.01 dB | -3.01 dB |
| DC Gain | 0.00 dB | 0.00 dB | 0.00 dB | 0.00 dB |
| Pass-Band Ripple | 0.00 dB | 0.00 dB | 0.00 dB | 0.00 dB |
| Stop-Band Frequency | 5.9465 Fc | 11.863 Fc | 1.7479 Fc | 3.4688 Fc |
| Cutoff Frequency Phase | -180.0 deg | -101.5 deg | -360 deg | -161.9 deg |
| Phase Distortion (DC to Fc) | < 31.8 deg | < 3.7 deg | < 102 deg | < 0.05 deg |
| Zero Frequency Group Delay | 0.4117/Fc | 0.2920/Fc | 0.7197/Fc | 0.4496/Fc |
| Percent Overshoot | 11.1% | 0.5% | 18.9% | 1.1% |
| 1% Settling Time | 1.65/Fc | 0.66/Fc | 4.03/Fc | 1.25/Fc |
| 0.1% Settling Time | 2.72/Fc | 0.77/Fc | 7.02/Fc | 2.25/Fc |
| -0.1 dB Frequency | 0.635 Fc | 0.182 Fc | 0.8538 Fc | 0.1800 Fc |
| -1 dB Frequency | 0.8487 Fc | 0.5741 Fc | 0.9437 Fc | 0.5685 Fc |
| -2 dB Frequency | 0.9370 Fc | 0.8129 Fc | 0.9772 Fc | 0.8087 Fc |
| -3.01 dB Frequency | 1.0000 Fc | 1.0000 Fc | 1.0000 Fc | 1.0000 Fc |
| -20 dB Frequency | 1.7412 Fc | 3.0248 Fc | 1.2149 Fc | 2.2342 Fc |
| -40 dB Frequency | 2.9555 Fc | 5.6932 Fc | 1.4443 Fc | 2.7556 Fc |
| -60 dB Frequency | 4.5986 Fc | 9.0980 Fc | 1.6391 Fc | 3.2016 Fc |
| -80 dB Frequency | 5.9465 Fc | 11.8629 Fc | 1.7479 Fc | 3.4688 Fc |

28454A OUTPUT CHARACTERISTICS

Type: DC-coupled, single-ended output
Prog. wide-band (500 kHz) or filtered
Z: 50 Ω shunted by 100 pF
Max Output: ± 10 Vpk, ± 20 mA pk
Offset Drift: 1 $\mu\text{V}/^\circ\text{C}$, RTI + 150 $\mu\text{V}/^\circ\text{C}$, RTO, typ
Noise: 2 μVrms RTI + 300 μVrms RTO, typ
3 Hz to 200 kHz
Crosstalk: -80 dB, DC to 25 kHz between
adjacent channels with the same
configuration and programmed settings

Auto-Offset Adjust (Standard)

Auto-offset automatically zeroes offset at the channel output to less than 5 mV at any gain setting. The auto-offset cycle is initiated in the GUI. Offset DAC settings are stored in non-volatile memory on the card for every gain setting. Changes in gain result in minimal disruption of the channel.

Output Monitor (Standard)

Output Monitor: A switch located at the output of each channel allows for multiplexed connection to the mainframe output monitor bus. The output monitor bus is available at a connector located in the 17th slot at the rear of the mainframe. The monitor function is used by the Test Subsystem or is available to the user for viewing channel outputs.

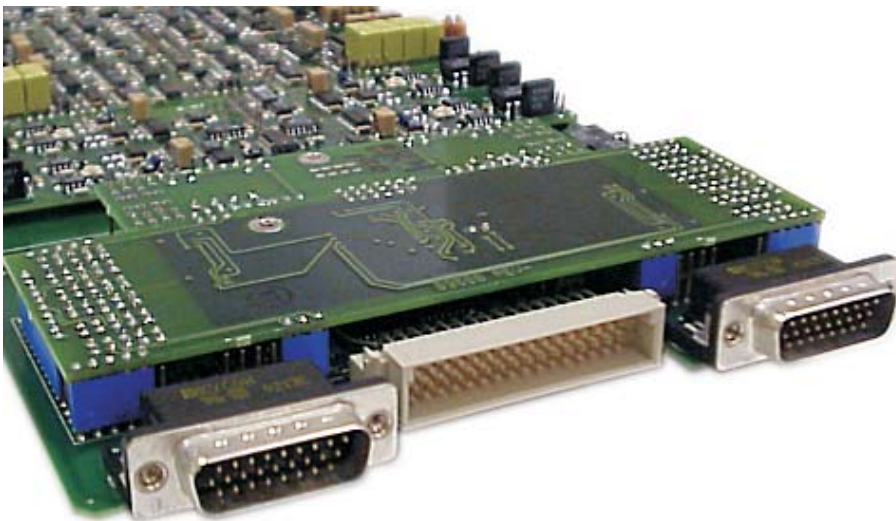

28454A Back Panel Connectors

28454A CARD GENERAL CHARACTERISTICS

28454A Card Size: 6.6 x 17.5 x 0.75 inches

Card Weight: 1.5 lb. Net

Temperature: 0° to 40° C (operating)
-20° to 70° C (storage)

ORDERING INFORMATION

28454A-Filter Type

LP4FP (4-pole low-pass)

LP8FP (8-pole low-pass)

ACCESSORIES

Input Mating Connectors

The input connectors are integral to the 28454A. Cutouts on the 28000 frames allow for the input connector to pass through the backplane to directly mate with the input cable. Two connectors required per slot (4 channels).

CONN-IN-26D-MTL: High-Density 26-pin D-shell mating connector with machined crimp pins and backshell with large cable opening and strain relief.

CONN-IN-26D-SC-MTL: High-Density 26-pin D-shell mating connector with machined solder cup pins and backshell with large cable opening and strain relief.

Output Mating Connectors

The 28016-M3 mainframe contains four 50-pin D-shell connectors mounted on the rear panel. The 28008-M3 frame provides two 50-pin D-shell connectors. Sixteen twisted pairs are accommodated per connector. One output mating connector is required per 16 channels (i.e., a set of four card slots).

CONN-OUT-50D: 50-pin D-shell mating connector with crimp pins and backshell with strain relief.

CONN-OUT-50D-SC: 50-pin D-shell mating connector with solder cup pins and backshell with strain relief.

Output Buffer Modules

The 28454A front panel auxiliary output connector accommodates Precision Filters output adapter modules to provide multiple buffered outputs per channel. Refer to the 28000 Output Buffer Module specification sheet for more information.

28000-RMS/DC4 Output Module: Quad channel RMS-to-DC converter module.

BUFF-4BNC/15D: Quad output buffer with single output per channel on 4 BNC connectors and one 15-pin multipin connector.

BUFF-4CH/(2)15C: Quad output buffer with dual outputs per channel on two 15-pin connectors.

