



Overview

28000 Analog Signal Conditioning System

The new standard for the world's most discriminating test labs.



The Precision 28000 Signal Conditioning System provides all the flexibility you need to manage your test measurements.

The Precision 28000 makes it easy to manage a test with hundreds of channels and a mix of transducers. Choose charge, IEPE w/TEDS, voltage (filter amplifier), strain, thermocouple, RTD, potentiometer, current, frequency, or other transducers.

The built-in test hardware and software (optional) provide quick go/no-go tests which can be run before each test, and rigorous factory acceptance tests to assure you that the 28000 meets your most stringent requirements for critical applications. It won't be long before these tests earn a permanent place in your maintenance routine. And since they are traceable to NIST, they eliminate the need for off-site calibration.

In every phase of your tests—record keeping, installation, design, set-up, operation, maintenance and upgrading—the Precision 28000 offers ways to help you save time and money over the life of the system.

28000 System Features

- Graphical User Interface (GUI) and Ethernet network interface for system control
- Intelligent gain and system scaling algorithms
- Test input and output monitor busses
- Go/no-go test with diagnostics to be used before tests
- Rigorous factory acceptance test for maintenance
- Field swappable AC power supplies
- Built-in temperature and power supply monitoring with alarms

Precision 28144 Quad-Channel Wideband Transducer Conditioner with Voltage and Current Excitation

28144 Quad-Channel Wideband Transducer Conditioner with Voltage and Current Excitation offers four channels of conditioning to support a wide variety of transducers including those that require constant voltage excitation or constant current excitation. Balanced constant voltage excitation in a bridge configuration supports applications such as strain gages and pressure transducers. Balanced current excitation accommodates single arm static or dynamic strain gages, RTDs or other resistive transducers that require constant current to excite them. Gain is programmable to x8192.



Precision 28144 Features

- Four channels per card, 64 channels per 28016 chassis
- Balanced programmable constant voltage excitation with remote sense – up to 20 V delivered to the bridge
- Balanced differential constant current excitation (20 mA/20 V compliance) with AC current test mode for verifying transducer, cabling and frequency response
- On-the-fly report of measured transducer excitation and resistance
- Transducer open/short indication
- Transducer leakage resistance measurement in constant current excitation mode, Option L
- Automatic bridge balance/transducer suppress
- Up to 204.6 kHz “filtered” bandwidth or 500 kHz “wide-band” bandwidth
- 2 to 10-wire plus shield bridge input interface
- 2 or 4-wire input plus shield transducer interface with constant current excitation
- Programmable AC/DC input coupling
- Programmable gain: x1/4 to x8192 with 0.05% vernier
- 4 or 8-pole low-pass filters with programmable pulse/flat characteristics
- Overload detection
- Precise digital calibration
- Programmable 5000 step (BC6 completion module) or single step (BC7 completion module) bipolar shunt cal
- Programmable bridge configuration: 1-arm, 2-arm or 4-arm bridges
- Programmable bridge resistance: 120 Ω , 350 Ω or 1 k Ω
- Front panel connectors that accept output adapter modules for multiple buffered outputs per channel

28144

Applications

- Static or dynamic strain gage conditioner
- Full bridge conditioner
- Pressure transducer conditioner
- Piezoresistive accelerometer conditioner
- RTD conditioner
- Load cell conditioner
- MEMS transducer conditioner
- Hot wire anemometry
- AC or DC filter/amplifier (<1 mV to 10 V inputs)

Precision 28144 Description

Precision 28144 Description

The 28144 is a member of the Precision 28000 family of signal conditioners. The 28144 provides four channels of conditioning for transducers requiring constant current or constant voltage excitation. Up to sixteen 28144 cards may reside in the 28000 system to provide 64 channels per chassis. In addition, the 28144 may be mixed with other conditioners in the 28000 family to meet your unique signal conditioning requirements.

Large changes in sensor impedance or sensor excitation can indicate that data from this sensor is no longer meaningful. The unique transducer health monitor circuits of the 28144 provide an “on-the-fly” report of measured sensor excitation and resistance. Measured gage resistance is compared to user specified limits and flagged if out of tolerance. Also, the 28144 alerts the user to a transducer open or short condition. The input overload detector reports overloads by out-of-band signals which could cause in-band distortion.

The 28144 features precise, automatic calibration of gain and offset for the entire channel, including the amplifier, filter, and excitation supply. Programmable bridge configuration and shunt calibration are supported on all four channels of the 28144 card via the optional BC plug-on module. The BC6 or BC7 modules support programmable bridge configuration for quarter, half or full bridges and programmable completion for 120 Ω , 350 Ω or 1 k Ω bridges. The BC6 provides over 5000 steps of bipolar shunt calibration while the BC7 has bipolar single-step precision resistor shunt cal. Dedicated shunt cal lines are provided that allow the user to perform the shunt cal on non-current carrying leads.

Balanced Constant Voltage Excitation

The 28144 provides balanced constant voltage excitation of up to 20 volts and conditioning for 1-, 2-, and 4-arm resistive bridges. The 28144 features automatic calibration of gain and offset for the entire channel, including the amplifier, filter, and excitation supply. The 2- to 10-wire input connection provides 6 wires for the bridge, 3 wires for shunt calibration, 1 wire for the shield, and 1 wire for single-arm bridges. Automatic balance of the bridge is accomplished by inserting a voltage ratiometric with the excitation supply to the amplifier input stage. This balance method provides outstanding stability without loading the bridge. A wide range of unbalanced conditions may be accommodated.

Balanced constant voltage excitation offers a number of advantages over single-ended excitation. It enables a true balanced instrumentation amplifier input for outstanding rejection of high frequency common mode signals. Single-ended voltage excitation to balanced bridges produces a relatively large common mode voltage at half the excitation supply. The instrumentation amplifier must reject this signal. Balanced voltage excitation applied to balanced bridges results in lower common mode input voltages to the amplifier input stage.

The excitation supply has automatic amplitude and offset correction that may be run on the unit in place at any time. Dedicated remote sense lines allow the excitation supply regulator to deliver an accurate voltage to the bridge.

Balanced Constant Current Excitation

The 28144 is equipped with Precision Filters' proprietary balanced differential constant current excitation that is optimized for making dynamic strain measurements on single active strain gages. Balanced constant current excitation provides an accurate means of measuring dynamic strain with a single active strain gage using only a two-wire connection. Electrostatic pickup is reduced when compared to single-ended constant current excitation or a quarter bridge configuration with remote completion resistors or unbalanced current sources. The balanced current excitation circuit operates properly even under certain common gage fault conditions such as a direct short of the gage to the test model.

Balanced constant current excitation provides a true balanced input for rejection of common-mode signals. Programmable excitation provides 0 to ± 20 mA of constant current with an “excitation off” mode to detect input cable noise pickup. Gage open/short detection is also provided.

For dynamic strain conditioning applications, the 28144 can provide accurate measurements with only two wires by AC coupling the input. For best AC or DC measurements (required for RTD type transducers), the 28144 provides a 4-wire Kelvin connection for remote sense. Constant current excitation may be applied to full bridge applications with the advantage that excitation delivered to the bridge is unaffected by excitation supply lead wire resistance.

Suppression of the gage DC operating point is performed automatically using the zero suppress feature of the 28144. Zero suppress allows the use of more gain to emphasize small gage fluctuations. Zero suppress also provides the user with an accurate means to balance a full bridge.

The excitation current source output may be modulated to allow AC current injection in the loop. The frequency and amplitude of the AC current is user controlled. This allows the user to simulate changes in gage resistance in the loop and provides direct AC input stimulation to the signal conditioner for end-to-end system calibration.

Input Stage

The 28144 input stage provides 120 dB of common-mode rejection and may be either AC or DC coupled. AC coupling is useful for dynamic applications where the DC bias on the transducer, that can limit dynamic range, can be coupled out of the signal. With the input DC coupled, low drift and ultra low noise (< -163 dBV/ $\sqrt{\text{Hz}}$) is provided by the 28144 input stage. The input stage may be shorted under program control to verify signal conditioner channel noise and DC offsets.

A switch at the input stage is provided to connect the amplifier to the 28000 system test bus. The test bus is used to inject signals for performance verification. In addition, both drive and sink current levels may be monitored separately making it possible to detect excitation current leakage conditions in the external current loop.

Amplifier and Filter

Programmable pre- and post-filter amplifiers provide an overall gain of 8192. Gain is distributed both before and after the filter to provide protection from large out-of-band energy or transients that could cause clipping before the filter, distorting the data. The Gain Wizard in the GUI allows the user to set a gain reserve and then apportions the gain between the input and output. This provides input gain for best noise performance yet conforms to the limitations of the user's worst case estimate of out-band or transient signals. Overload detectors alert the user to over-voltage conditions. A fully buffered output having over 25 mA of drive capability may be used to drive long output cable runs.

The 28144 may be specified with a 4 or 8-pole low-pass filter or an 8-pole band-pass filter with cutoffs programmable from 1 Hz to 204.6 kHz and programmable "flat" or "pulse" mode. The "flat" mode provides pass-band characteristics nearly identical to a Butterworth filter while providing a much sharper roll-off. This mode is a good choice for applications such as spectral analysis. The "pulse" mode has time domain response similar to the Bessel filter yet provides superior amplitude response characteristics. The "pulse" mode is ideal for time domain applications including transient (shock) measurements and time domain waveform analysis.

Verification of Cables and Sensor Health:

Strain Gage Loop Resistance Measurement:

Dynamic strain measurements often require complicated wiring schemes. Long cable runs, multiple connection points, high-temperature high-impedance very small diameter wire and slip rings combine to cause uncertainty in the strain gage connection. Often a sudden increase in gage resistance is a predictor of gage failure. The Precision 28144 gives continual real time monitoring of the total "Loop Resistance" of the gage and cable circuit. This loop resistance reading can be compared to preset limits to alert the user of unexpected resistance shifts as well as gross gage short and gage open conditions.

Cable Roll-off: One often asked question of many measurements engineers is "How will my cable capacitance affect my high frequency strain measurement"? This question can be answered quickly and easily and all from the convenience of the control room. The AC dither current feature of the 28144 modulates a small AC current on top of the DC excitation current to stimulate an AC signal across the actual strain gage sensing element. Since the stimulus signal is based at the sensor, it will exhibit the same roll-off characteristics as a signal resulting from actual dynamic strain. The test frequency of the dither signal can be increased as necessary to chart the cable roll-off characteristics and validate the cable circuit for use at the desired measurement frequencies.

Gage Leakage Measurements: In extremely hot sections of a gas turbine engine, it is impossible to use standard insulating materials in gage wiring. Often a rigid section of a stainless steel or Inconel sheath encloses high temperature inner conductor wires. The inner core of the sheath is filled with magnesium oxide (MGO) as a high temperature insulating material. The insulating properties of the MGO are affected by moisture absorption at damage points or improperly sealed cable terminations. In extreme conditions, insulation breakdown can cause a leakage path to ground and corrupt a gage reading. Other causes of cable leakage are fatigue or failure at extension wire tie-down points, or in the strain gage itself. The leakage detection feature of the 28144 continually monitors leakage and compares readings to preset threshold limits. Sensors which show higher than normal leakage can be quickly identified prior to or during the test run.

Muting Faulty Sensors:

Depending on the sensor type, various techniques must be used to quiet the channel's input and output circuits and ensure that no noise coupling occurs. For example, an intermittent gage will create a gage chatter condition whereby the connecting wires continually switch between the high voltage fault level and the proper low voltage operational level. This chatter condition creates a hostile noise source to any other gage extension wires in the vicinity of the hostile cable. Precision 28144 signal conditioning channels have a "MUTE" feature, which places the channel in its quietest quiescent state and minimizes the possibility of coupling noise to properly functioning channels.

28144 Programmable Features

- Constant voltage excitation level: 0 to 20.475 V in 5 mV steps
- Constant current excitation level: 0 to 20.475 mA in 5 μ A steps
- Expected transducer resistance and tolerance
- Transducer leakage resistance thresholds
- Voltage excitation sense: instrument or gage
- Current excitation input interface: 2-wire or 4-wire
- Bridge configuration: 1-arm (2-wire), 1-arm (3-wire), 2-arm or 4-arm
- Bridge resistance: 120 Ω , 350 Ω or 1 k Ω
- Shunt cal: instrument or gage
- Shunt cal resistance and shunt arm: R1 or R2
- Automatic balance/suppress
- AC/DC input coupling
- Test modes: amp short, excitation off, test bus (voltage substitution), shunt calibration, AC current, excitation monitor
- Output monitor
- Gain: x1/4 to x8192 with 0.05% resolution
- Filter type: pulse or flat
- Cutoff frequency: 2 Hz to 204.6 kHz, flat mode
1 Hz to 102.3 kHz, pulse mode
- Wide-band (500 kHz) or filtered operation

28144 Graphical User Interface Display

All programmable features in addition to:

- On-the-fly excitation monitor
- On-the-fly sensor resistance monitor with pass/fail status
- Sensor open or short indication
- Configuration read back
- Balance/Suppress status
- Input wiring
- Transducer sensitivity
- System scaling in engineering units
- Overload status
- Intelligent gain algorithm
- Group control

28144 Filter Characteristics

You want your analog data to come clean before digital conversion.

The 28144 Card has a variety of high performance filter characteristics available for HP, LP or BP Precision filtering.

Flat/Pulse Low-Pass Filters

Our new choice of LP4FP 4-pole or LP8FP 8-pole flat/pulse low-pass filters provide the user with the versatility to address applications in either the time or frequency domain and are available on many 28000 card models. Frequencies can range as high as 204.6 kHz with fixed frequency choices for economy.

LP4F and LP4P Amplitude Response

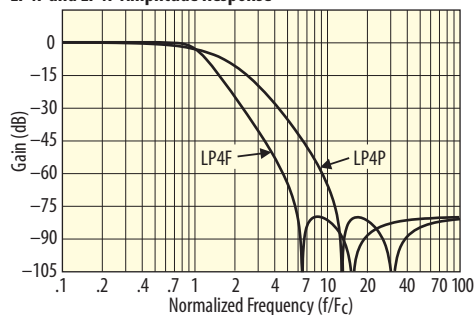

LP8F and LP8P Amplitude Response

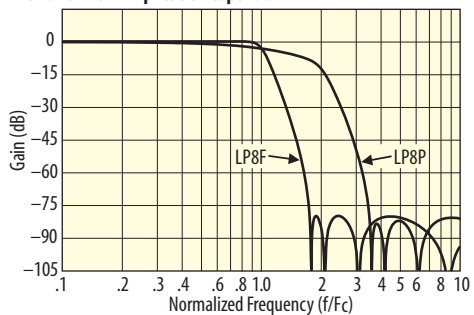

Flat Mode Low-Pass Filters

Precision LP4F and LP8F "flat" mode characteristics are specified to have outstanding passband flatness equivalent to the Butterworth yet deliver very sharp roll-off characteristics.

LP4F and LP8F vs Butterworth Amplitude Response

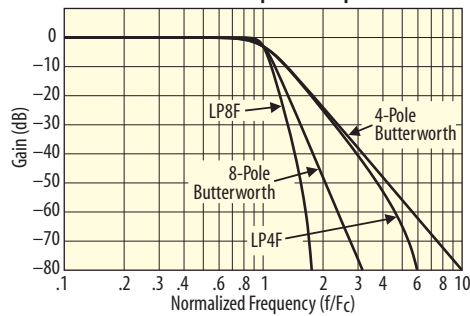

The LP4F and LP8F are a good choice as an anti-aliasing filter and for applications such as spectral analysis. The LP8F has zero passband ripple and over 100 dB/octave attenuation slope.

LP4F and LP8F vs Butterworth Passband Response

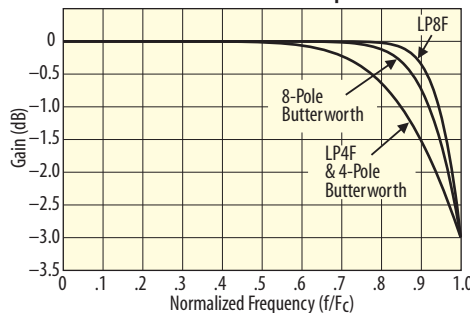

Pulse Mode Low-Pass Filters

For the time domain, there are the LP4P and LP8P "pulse" mode low-pass filters. These filters have excellent transient response and phase linearity making them ideal filters for time domain applications including transient (shock) measurements and time domain waveform analysis ... all with roll-off characteristics superior to their Bessel filter counterparts.

LP8P vs 8-Pole Bessel Amplitude Response

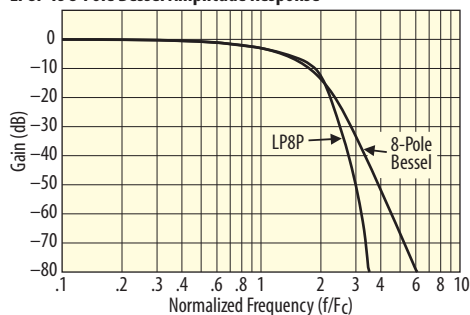

LP8P and LP4P Passband Response

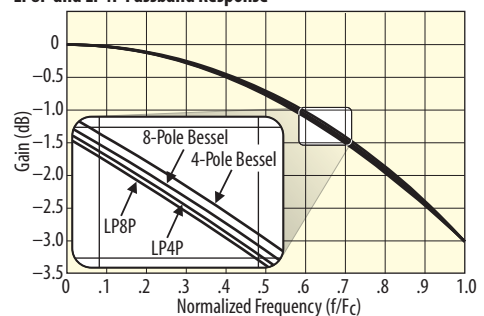

LP8P and LP4P Step Response

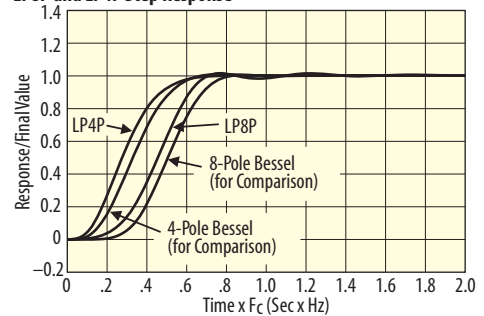

High-Pass and Band-Pass Filters

For high-pass filtering, we offer the HP4F 4-pole characteristics. For band-pass filtering, choose the HP4F/LP4FP band-pass characteristic to provide programmable bandwidth and center frequency filters.

Band-Pass Amplitude Response HP4F and LP4F Cascaded

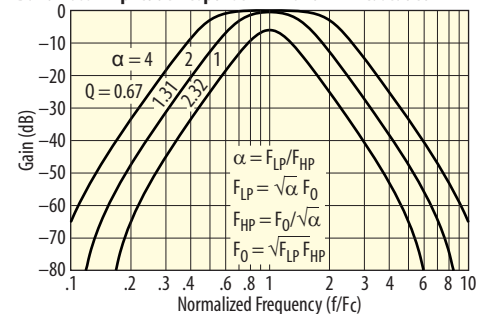

Traditional Filters

Of course, we offer the traditional filter types such as Butterworth and Bessel characteristics ... just ask!

In any case, we deliver to you a tightly controlled filter with phase match better than 1 degree and usually better than 0.5 degrees.

28144 Details and Specifications

28144 Conditioner Cards

The detailed description and specifications for the 28144 are organized as follows in the sections below:

- Card Model Number Structure
- Programmable Bridge Configuration Modules
- Bridge Wiring
- Excitation Supply
- Input Characteristics
- Amplifier Characteristics
- Test Modes
- Filter Type Characteristics
- Output Characteristics
- General Characteristics
- Accessories
- Ordering Information

Programmable Bridge Configuration Modules

Constant Voltage Excitation Mode:

The optional BC plug-on bridge configuration modules provide support for programmable bridge configuration. In addition, the BC6 and BC7 modules support programmable shunt calibration for all four channels on the 28144 card when using constant voltage excitation. The BC8 module provides conditioning for modulated current output transducers, such as those with 4-20 mA outputs.

All completion modules may be programmed to support 1-arm, 2-arm or 4-arm (quarter, half or full) bridge configurations. Completion resistance is programmable for 120 Ω , 350 Ω or 1 k Ω . Completion resistors are metal foil technology and are very precise and very stable.

The BC6 shunt calibration utilizes voltage insertion at the bridge, providing over 5000 steps of single shunt calibration of bridge arms R1 or R2. The user may program the shunt to be applied at the gage (if additional cable wires are used) or at the instrument. Shunt sensitivity is set by a precision resistor on the BC6 card and is programmable from $\pm 125 \mu\text{V}$ per V of programmed excitation to $\pm 8 \text{ mV/V}$ in 0.2% resolution. The effective range of shunt resistor values is 30.75 to 2000 times the bridge programmed bridge resistance. The BC6 shunt calibration may only be used in conjunction with constant voltage excitation.

The BC7 provides traditional single-step bipolar shunt cal using a precision resistor. Single shunt of either R1 or R2 bridge arms may be selected. The standard BC7 shunt cal supplied with 120 Ω , 350 Ω and 1 k Ω cards produces 1 mV/V single shunt. Custom shunt resistor values may be specified.

The BC8 supports 2-wire or 4-wire connections to modulated current output devices that require a constant voltage power supply to excite them and provide a current output proportional to the measurement units. This includes sensors with 4-20mA outputs. The BC8 switches a 250 ohm resistor across the amplifier input to measure the sensor current output.

The BC9 completion module supports programmable bridge completion only.

Constant Current Excitation Mode:

When using constant current excitation, the bridge configuration modules provide programmable configuration of 2-wire or 4-wire input mode. 2-wire mode is useful for dynamic strain measurements where the input stage of the amplifier is AC coupled. The 4-wire mode may be used to make static measurements with a Kelvin connection to the gage. The 28144 zero suppress circuit can be used to zero the transducer bias when operating in the 4-wire configuration. The wide range of the zero-suppress circuit can accommodate large transducer bias voltages.

Bridge Configuration Module Specifications:

Completion Resistors:

120 Ω , 350 Ω and 1 k Ω , programmable

Bridge Configuration:

1-arm, 1-arm w/ 3 wires, 2-arm or 4-arm, (programmable)

Resistor Temperature Coefficient:

$\pm 0.2 \text{ ppm} / ^\circ\text{C}$

Resistor Accuracy:

$\pm 0.02\%$

BC6 Shunt Calibration (Constant Voltage Excitation Mode Only):

Shunt Selection:

R1 or R2 bridge arms

Equivalent Shunt Resistance Settings:

30.75R to 2000R w/ 0.2% minimum resolution where R = 120 Ω , 350 Ω or 1 k Ω

Shunt Sensitivity:

$\pm 0.125 \text{ mV/V}$ to $\pm 0.5 \text{ mV/V}$
in $\pm 0.25 \mu\text{V/V}$ steps
 $\pm 0.501 \text{ mV/V}$ to $\pm 2.0 \text{ mV/V}$
in $\pm 1.00 \mu\text{V/V}$ steps
 $\pm 2.004 \text{ mV/V}$ to $\pm 8.0 \text{ mV/V}$
in $\pm 4.00 \mu\text{V/V}$ steps

Shunt Accuracy:

$\pm 0.2\%$ for programmed excitation $> 1 \text{ V}$

BC7 Shunt Calibration:

Shunt Selection:

R1 or R2 bridge arms

Shunt Sensitivity:

$\pm 1 \text{ mV}$ per volt of programmed excitation

Shunt Resistance:

29.940 k Ω for 120 Ω bridge
87.325 k Ω for 350 Ω bridge
249.5 k Ω for 1 k Ω bridge

Resistor Accuracy:

$\pm 0.1\%$

BC8 Current Sense:

Modes:

2-wire sense or 4-wire sense

Sense Resistor:

250 ohms $\pm 0.1\%$

Bridge Wiring

Input Connector:

26-pin D-shell (2 ea.)

Input Wires:

\pm EXCITATION (2)
 \pm SENSE (2)
 \pm SIGNAL (2)
SHUNT CAL (3)
¼ Bridge RTN (1) Single Arm Bridge
SHIELD (1)

28144 Details and Specifications

Bridge Configuration Diagram with BC6 Bridge Configuration Module

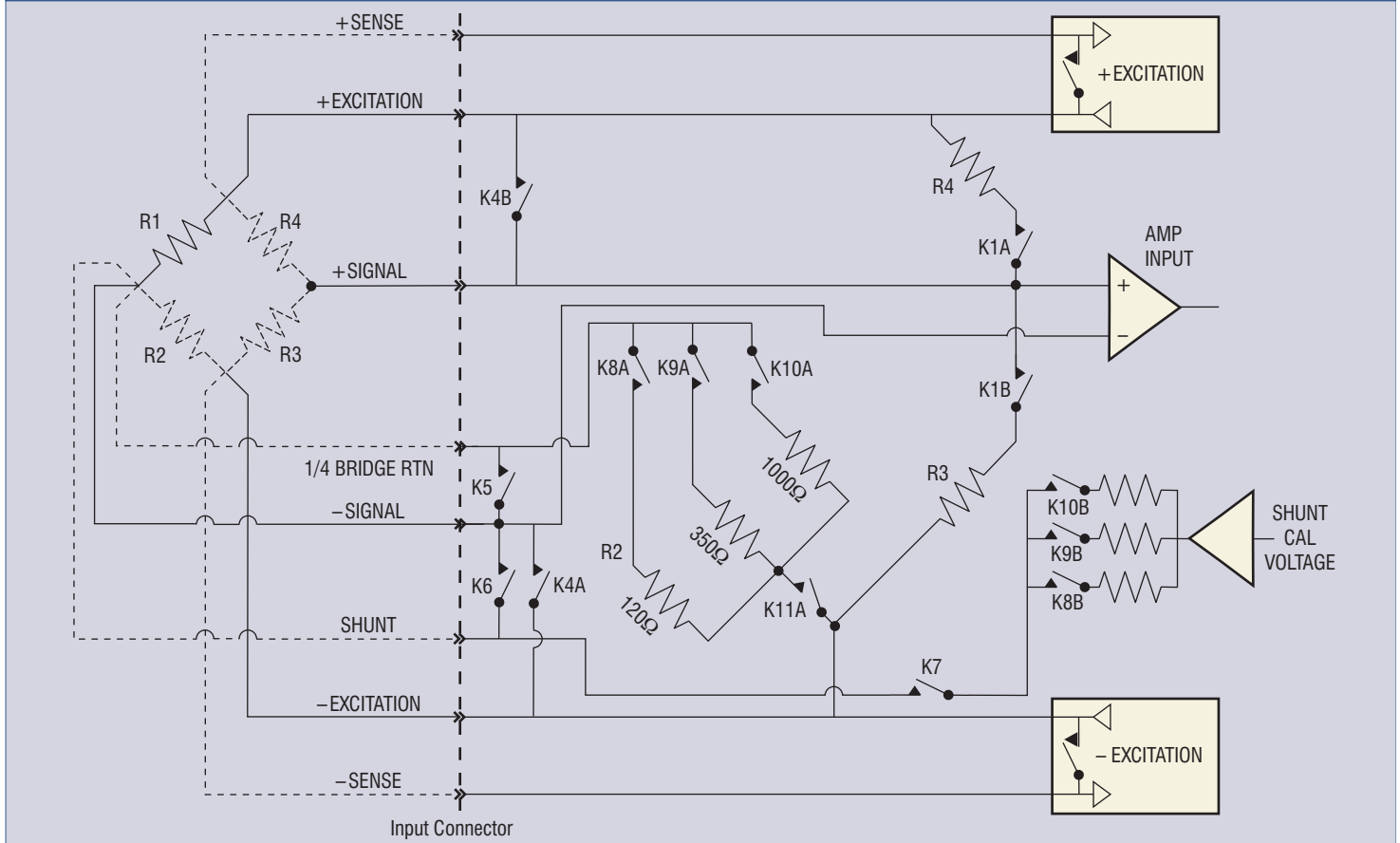

Truth Table

Configuration	K1	K4	K5	K6	K7	K8	K9	K10	K11
¼ Bridge, 2-Wire	IN		IN			IN ¹	IN ¹	IN ¹	IN
¼ Bridge, 3-Wire	IN		OUT			IN ¹	IN ¹	IN ¹	IN
½ Bridge	IN					OUT	OUT	OUT	OUT
Full Bridge	OUT					OUT	OUT	OUT	OUT
120 Ohm Completion						IN	OUT	OUT	IN
350 Ohm Completion						OUT	IN	OUT	IN
1000 Ohm Completion						OUT	OUT	IN	IN
Shunt Cal Gage				OUT	IN				
Shunt Cal Instrument				IN	IN				
Constant Current 2-Wire		IN							
Constant Current 4-Wire		OUT							

¹ One switch selected at a time.

Bridge Configuration Diagram with BC7 Bridge Configuration Module

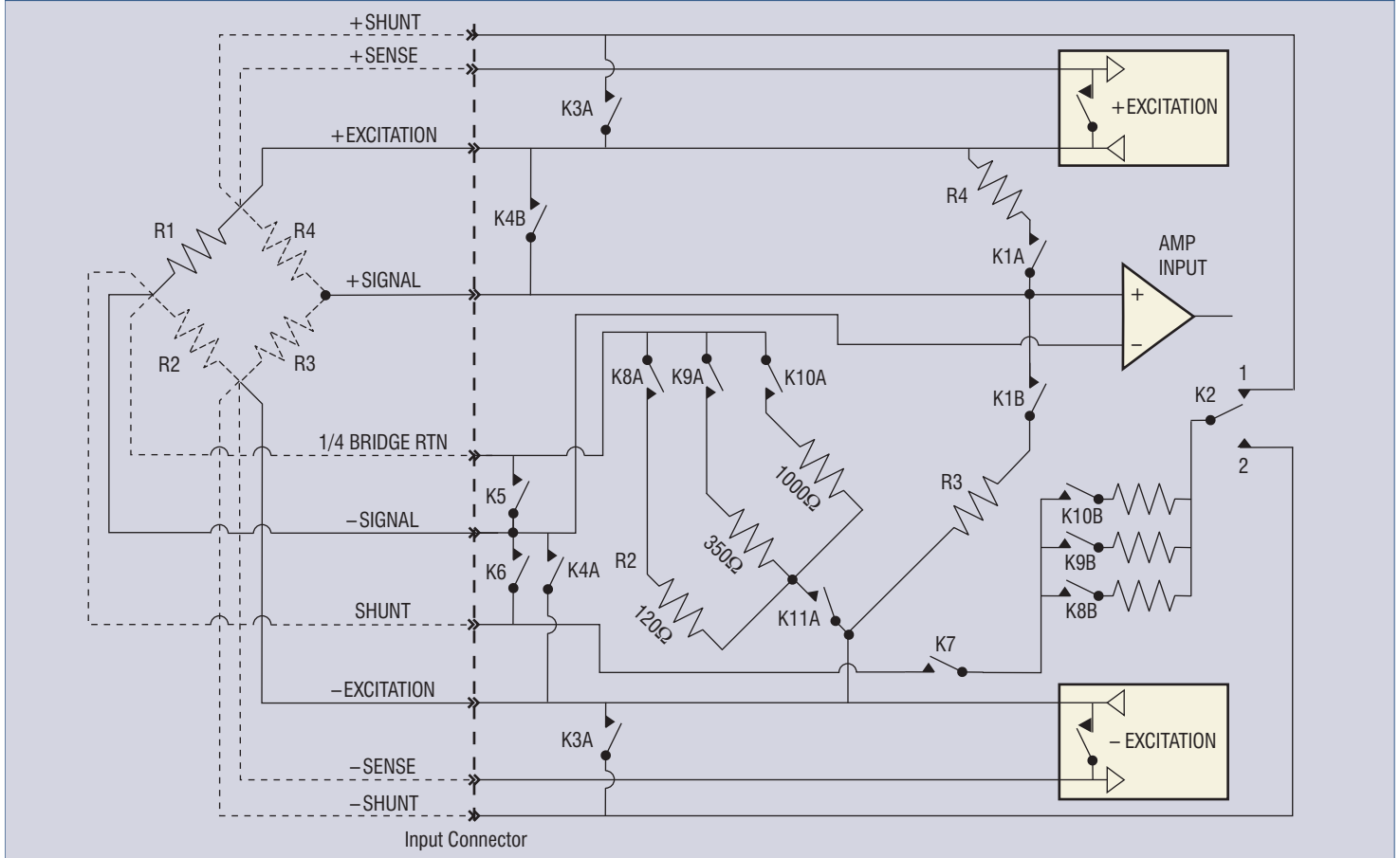

Truth Table

Configuration	K1	K2	K3, K6	K4	K5	K7	K8	K9	K10	K11
¼ Bridge, 2-Wire	IN				IN		IN ¹	IN ¹	IN ¹	IN
¼ Bridge, 3-Wire	IN				OUT		IN ¹	IN ¹	IN ¹	IN
½ Bridge	IN						OUT	OUT	OUT	OUT
Full Bridge	OUT						OUT	OUT	OUT	OUT
120 Ohm Completion							IN	OUT	OUT	IN
350 Ohm Completion							OUT	IN	OUT	IN
1000 Ohm Completion							OUT	OUT	IN	IN
Shunt Cal Gage			OUT			IN				
Shunt Cal Instrument			IN			IN				
Shunt R1		1				IN				
Shunt R2		2				IN				
Constant Current 2-Wire				IN						
Constant Current 4-Wire				OUT						

¹ One switch selected at a time.

28144 Details and Specifications

28144 Excitation Supply Programmable Constant Voltage Excitation

Maximum Output:

20.475 V, 30 mA (balanced)

Steps:

Programmable from 0 to 20.475
in 5 mV steps

Excitation Sense:

Programmable (instrument or
gage sense)

Accuracy:

$\pm 0.03\%$, $\pm 500 \mu\text{V}$

Noise:

100 μVrms , 3 Hz to 200 kHz

Temperature Drift:

$\pm 0.0025\%/^{\circ}\text{C}$ of setting or $\pm 50 \mu\text{V}/^{\circ}\text{C}$,
whichever is greater

Sense Leakage Current:

Less than 10 μA

Calibration:

Automatically calibrated for gain and
offset. Calibration initiated at the GUI
panel.

Excitation Off:

The excitation supply is programmed
to 0 volts.

28144 Constant Current Excitation Supply

Type:

Balanced differential constant current
excitation

Excitation:

0 to 20.475 mA in 5 μA steps

Total Gage Voltage (Volts):

22 – 1 x 700 minimum

Input Impedance:

100 k Ω nominal per side

CMRR (DC to 1 kHz):

80 dB for 120 Ω gage

70 dB for 350 Ω gage

60 dB for 1 k Ω gage

Initial Accuracy:

0.05%, 5 μA

Temperature Drift:

30 nA + 0.0024% of setting per $^{\circ}\text{C}$

Noise:

65 pA/ $\sqrt{\text{Hz}}$ at 1 kHz

Bandwidth:

± 0.2 dB to 200 kHz (RGAGE < 1 k Ω)

28144 MUTE Mode

In harsh test environments, a sensor or input cable can become faulty or intermittent during a critical test. With high gain signal conditioning this can be troublesome if large signal swings on input or output cabling cross couple to other channels. The 28144 Mute control places the channel in the quietest operational state to minimize system noise in the event of a failed sensor. The Mute Mode is also useful to terminate unused channels in a safe and quiet state.

28144 Transducer Health Monitor

Sensor Excitation Monitor: Transducer excitation voltage or current is monitored and reported to the user on-the-fly. Measured excitation is compared to factory set tolerance and GUI indicators report if out of tolerance.

Sensor Resistance Monitor: Transducer resistance is monitored on-the-fly and compared to user defined limits. GUI indicators report if sensor resistance is out of user tolerance.

Sensor Open/Short Monitor: Transducer open or short condition is monitored and reported to the user via GUI indicators.

Transducer Leakage Resistance Measurement, Option L: The 28144 with Option L monitors gage bias levels in order to detect constant current excitation leakage conditions in the external current loop. Transducer leakage status is monitored and reported via the GUI.

Excitation Current Limit: Current limit protection is provided by the 28144 excitation supply. Possible causes of current limit are an incorrect excitation setting or a shorted transducer. Current limit indicators are provided in the GUI.

Excitation Thermal Shutdown: The excitation supply regulator die temperature is continuously monitored and will shut down should the temperature reach a level where damage to the excitation supply may occur. Thermal shutdown indicators are provided in the GUI.

28144 Constant Current Mode Transducer Interface

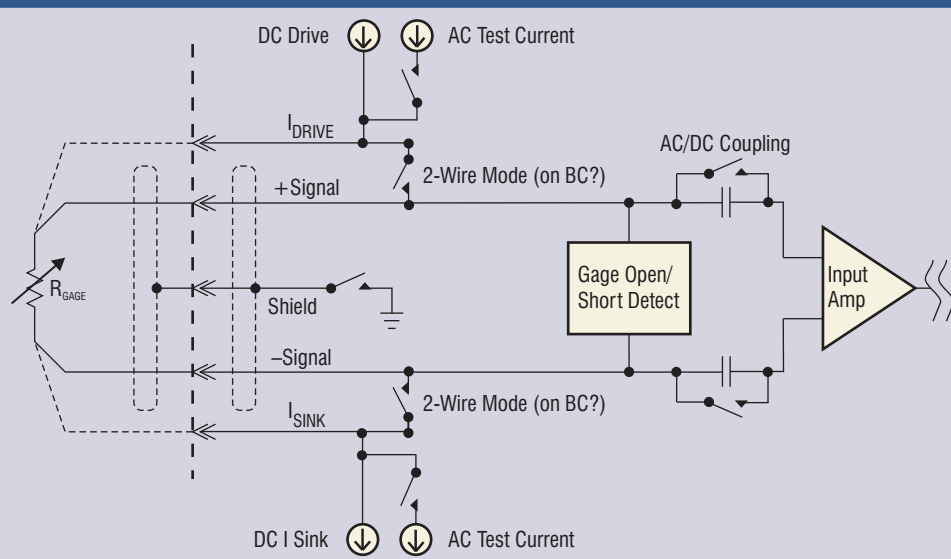

28144 Input Characteristics

Type:

Balanced differential w/ programmable AC/DC input coupling

Input Impedance:

10 M Ω //100 pF per side

Max Level (AC + DC + Common Mode):

± 10 Vpk for $f \leq 200$ kHz

± 10 Vpk x (200 kHz/f) for $f > 200$ kHz

Input Protection (Power On):

45 V continuous, 100 Vpk for 1 mS,
10% duty cycle

Offset Drift:

1 V/ $^{\circ}$ C, typical

Noise:

7 nV/ Hz at 1 kHz and pre-filter gain
> 64, typical

AC Coupling Frequency:

0.25 Hz (3.01 dB)

CMRR (DC Coupled):

110 dB, DC to 440 Hz and input gain
> x16

CMRR (AC Coupled.):

100 dB, 10 Hz to 440 Hz

Auto Bridge Balance Mode:

The bridge is automatically balanced utilizing voltage insertion at the input amplifier when bridge balance mode is selected. The inserted voltage is derived from and thus tracks the excitation supply. A successive approximation A/D converter mechanization is used for rapid bridge balance.

Range:

Bridge balance algorithm selects the most appropriate range to achieve balance with finest resolution.

32 mV/V Mode Auto-Balance Ranges:

± 0.0002 mV/V to ± 0.5 mV/V

in ± 0.244 μ V/V steps

± 0.502 mV/V to ± 4.0 mV/V

in ± 1.95 μ V/V steps

± 4.016 mV/V to ± 32.0 mV/V

in ± 15.625 μ V/V steps

512 mV/V Mode Auto-Balance Ranges

(Gain limited to x512):

± 0.004 mV/V to ± 8.0 mV/V

in ± 3.9 μ V/V steps

± 8.03 mV/V to ± 64.0 mV/V

in ± 31.25 μ V/V steps

± 65.25 mV/V to ± 512.0 mV/V

in ± 250 μ V/V steps

Accuracy:

$\pm 0.1\%$ of setting $\pm 0.1\%$ of F.S. range

Stability:

± 25 ppm / $^{\circ}$ C of setting

Drift (RTI):

± 0.3 μ V / $^{\circ}$ C for 32 mV/V range;

± 5 μ V / $^{\circ}$ C for 512 mV/V range

Auto Balance Time:

Less than 15 seconds per system of 64 channels.

Auto Suppress Mode:

A programmable DC offset derived from a precision 10 V reference is injected at the channel input stage to suppress the gage DC operating voltage. Manual or automatic suppression modes are supported.

640 mV Suppress Ranges:

± 0.005 mV to ± 10 mV in ± 4.9 μ V steps

± 10.04 mV to ± 80 mV in ± 39 μ V steps

± 80.31 mV to ± 640 mV in ± 312 μ V steps

10.24 V Suppress Ranges

(Gain limited to x512):

± 0.08 mV to ± 160 mV in ± 78 μ V steps

± 160.6 mV to ± 1.28 V in ± 625 μ V steps

± 1.285 V to ± 10.24 V in ± 5 mV steps

Accuracy:

$\pm 0.1\%$ of setting $\pm 0.1\%$ of F.S. range

Stability:

± 25 ppm / $^{\circ}$ C of setting

Drift (RTI):

± 0.3 μ V / $^{\circ}$ C for 640 mV range; ± 5 μ V / $^{\circ}$ C

for 10.24 V range

Auto Suppress Time:

Less than 15 seconds per system of 64 channels.

28144 Amplifier Characteristics

Pre-Filter Gain:

x1 to x512 in binary steps with overload detection (10.5 Vpk threshold)

Post-Filter Gain:

x1/4 to x16 in binary steps with vernier adjustment of 0.05% of setting

DC Accuracy:

0.1% after auto cal at any gain setting

Stability:

$\pm 0.02\%$ for 6 months

Temp Coef.: $\pm 0.004\%/^{\circ}$ C

DC Linearity:

$\pm 0.005\%$ re Fullscale, relative to the best straight line

Frequency Response:

DC to 200 kHz, 0 dB ± 0.1 dB

-3 dB typical @ 500 kHz

High Frequency Rolloff:

18 dB/octave

28144 Test Modes

Amplifier Short: A switch at the amplifier input is utilized to ground the input stage for measurement of noise and DC offset.

Test Bus: Test input allows for injection of a test signal. An external test signal or the 28000-?-TEST Test Subsystem may be connected at the rear panel. Refer to the 28000-?-TEST Test Subsystem specification for more information.

Shunt Cal: Applies shunt to bridge.

Excitation Monitor (Constant Voltage

Mode Only): The amplifier input is switched from the bridge to the excitation supply to monitor the excitation voltage at the amplifier output. Excitation monitor gain is x0.5.

Excitation Off: The excitation supply is programmed to zero volts or zero mA.

AC Current (Constant Current Mode

Only): An AC current is injected into the current loop to evaluate end-to-end system frequency response. The AC current is generated from a voltage waveform on the test bus.

Dither Bandwidth (350 ohm loop resistance at input connector):

-5% at 50 kHz, typical

-3dB at 165 kHz, typical

28144 Details and Specifications

28144 Filter Type Characteristics

Option LP4FP:

4-pole, 4-zero low-pass filter.
Programmable for maximally flat pass-band (LP4F) or linear phase with optimized pulse response (LP4P).

Option LP8FP:

8-pole, 8-zero low-pass filter.
Programmable for maximally flat pass-band (LP8F) or linear phase with optimized pulse response (LP8P).

Option HP4F/LP4FP:

8-pole, 8-zero band-pass filter.
Flat HP4F 4-pole, 4-zero high-pass filter cascaded with a 4-pole, 4-zero low-pass filter. Low-pass filter programmable for maximally flat pass-band (LP4F) or linear phase with optimized pulse response (LP4P).

Cutoff Frequencies:

Flat Mode:

2 Hz to 2.046 kHz in 2 Hz steps
2.2 kHz to 204.6 kHz in 200 Hz steps

Pulse Mode:

1 Hz to 1.023 kHz in 1 Hz steps
1.1 kHz to 102.3 kHz in 100 Hz steps

LP4F, LP4P, LP8F, LP8P:

Amplitude Accuracy:

±0.1 dB max, DC to 0.8 Fc
±0.2 dB max, 0.8 Fc to Fc

Amplitude Match:

±0.1 dB max, DC to 0.8 Fc
±0.2 dB max, 0.8 Fc to Fc

Phase Match:

±1° max, DC to 0.8 Fc
±2° max, 0.8 Fc to Fc

HP4F:

Amplitude Accuracy:

±0.1 dB max, 1.2 Fc to 204.6 kHz
±0.2 dB max, Fc to 1.2 Fc

Amplitude Match:

±0.1 dB max, 1.2 Fc to 204.6 kHz
±0.2 dB max, Fc to 1.2 Fc

Phase Match:

±1° max, 1.2 Fc to 204.6 kHz
±2° max, Fc to 1.2 Fc

Bypass:

Bypasses filter but not amplifier stages.
Each filter may be independently bypassed for the HP4F/LP4FP band-pass filter.

Bypass Bandwidth:

500 kHz, typical

Note: Other filter types and cutoff ranges available upon request. Please consult factory.

Specification	LP4F Maximally Flat Low-Pass Filter	LP4P Constant Time Delay Low-Pass Filter	LP8F Maximally Flat Low-Pass Filter	LP8P Constant Time Delay Low-Pass Filter	HP4F Maximally Flat High-Pass Filter
Cutoff Frequency Amplitude	-3.01 dB	-3.01 dB	-3.01 dB	-3.01 dB	-3.01 dB
DC Gain	0.00 dB	0.00 dB	0.00 dB	0.00 dB	-80 dB
Pass-Band Ripple	0.00 dB	0.00 dB	0.00 dB	0.00 dB	0.00 dB
Stop-Band Frequency	5.9465 Fc	11.863 Fc	1.7479 Fc	3.4688 Fc	0.1682 Fc
Cutoff Frequency Phase	-180.0 deg	-101.5 deg	-360 deg	-161.9 deg	180 deg
Phase Distortion (DC to Fc)	< 31.8 deg	<3.7 deg	<102 deg	<0.05 deg	-
Zero Frequency Group Delay	0.4117/Fc	0.2920/Fc	0.7197/Fc	0.4496/Fc	-
Percent Overshoot	11.1%	0.5%	18.9%	1.1%	-
1% Settling Time	1.65/Fc	0.66/Fc	4.03/Fc	1.25/Fc	1.86/Fc
0.1% Settling Time	2.72/Fc	0.77/Fc	7.02/Fc	2.25/Fc	2.92/Fc
-0.1 dB Frequency	0.6348 Fc	0.1816 Fc	0.8538 Fc	0.180 Fc	1.5753 Fc
-1 dB Frequency	0.8487 Fc	0.5742 Fc	0.9437 Fc	0.5685 Fc	1.1783 Fc
-2 dB Frequency	0.9370 Fc	0.8129 Fc	0.9772 Fc	0.8087 Fc	1.0672 Fc
-3.01 dB Frequency	1.0000 Fc	1.0000 Fc	1.0000 Fc	1.0000 Fc	1.0000 Fc
-20 dB Frequency	1.7412 Fc	3.0248 Fc	1.2149 Fc	2.2342 Fc	0.5743 Fc
-40 dB Frequency	2.9555 Fc	5.6932 Fc	1.4443 Fc	2.7556 Fc	0.3384 Fc
-60 dB Frequency	4.5986 Fc	9.0980 Fc	1.6391 Fc	3.2016 Fc	0.2175 Fc
-80 dB Frequency	5.9465 Fc	11.8629 Fc	1.7479 Fc	3.4688 Fc	0.1682 Fc

28144 Output Characteristics

Type:

DC coupled, single-ended output with ground sense

Output Ground Sense:

Used for driving grounded single-ended loads. Output is referred to ground at the load. Output sense also reduces ground loop interference by providing a high impedance connection between the ground at the load and the output stage ground.

Impedance:

Hi Output: $10\ \Omega // 100\ \text{pF}$

Low Output (Sense Input):

$100\ \Omega // 100\ \text{pF}$ or ground via manual card switch.

Output Shield:

Selectable ground or open via manual card switch.

Max Output:

$\pm 10\ \text{Vpk}, \pm 25\ \text{mA pk}$

Offset:

$< 5\ \text{mV}$ after auto-adjust at any gain setting

Offset Drift:

$1\ \mu\text{V}/^\circ\text{C}, \text{RTI} + 150\ \mu\text{V} / ^\circ\text{C RTO}$

Noise:

$2.8\ \mu\text{V rms RTI} + 60\ \mu\text{V rms RTO},$
3 Hz to 100 kHz

Crosstalk:

$-90\ \text{dB}, \text{DC to } 100\ \text{kHz}$

Output Monitor:

A switch at the output of each channel allows for multiplexed connection to the 28000 chassis output monitor bus BNC connector for viewing the channel output with an external device.

28144 General Characteristics

28144 Card Size:

6.63 x 17.5 x 0.75 inches

Card Weight:

1.4 lb. net

Temperature:

$0\ ^\circ\text{C to } 40\ ^\circ\text{C}$ (operating);

$-20\ ^\circ\text{C to } 70\ ^\circ\text{C}$ (storage)

Connectors:

The input connectors are integral to the 28144 card. Cutouts on the 28000 frames allow the input connector to pass through the backplane and to directly mate with the input cables.

Two 26-pin high-density D connectors are utilized for the 4 inputs (2 inputs per connector). Connectors have high quality machined gold plated pins/sockets.

28144 outputs are available on 50-pin D connectors that are integral to the 28000 System chassis. Three wires per output are provided to accommodate twisted/shielded cables.

28144 Channel Block Diagram

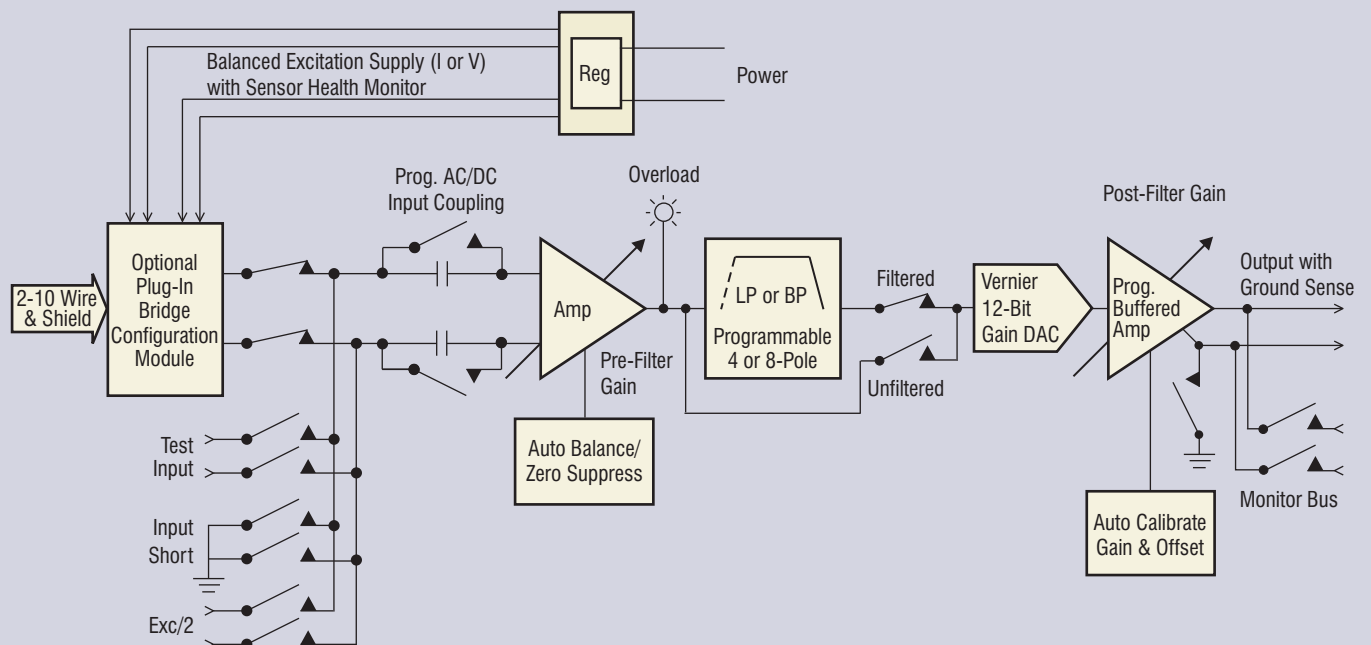

Accessories

Mating Connectors

Precision Filters mating connectors accommodate up to 22-AWG wire and are supplied with high quality metal backshells and gold plated screw machined contacts for high reliability connections and long service life.

CONN-IN-26D-MTL: High-Density 26-pin D-shell mating input connector with machined crimp pins and metal backshell with strain relief.

CONN-IN-26D-SC-MTL: High-Density 26-pin D-shell mating input connector with machined solder cup pins and metal backshell with strain relief.

CONN-OUT-26D-MTL: High-Density 26-pin D-shell mating output connector with machined crimp pins and metal backshell with strain relief.

CONN-OUT-26D-SC-MTL: High-Density 26-pin D-shell mating output connector with machined solder cup pins and metal backshell with strain relief.

Output Adapters

Measurement systems often require multiple outputs per signal conditioning channel or special functions such as a DC output in proportion to the AC signal level. These outputs may be routed to control systems, tape backup systems, auxiliary data acquisition systems, scope bays and other destinations.

28144 cards are fitted with front panel connectors which accept Precision output adapter modules. Adapters plug on to the front of the signal conditioner card and are secured to the card by two screws. The adapters provide one or two additional fully buffered outputs per channel or RMS to DC functionality.

28000-RMS/DC4: Quad RMS-to-DC Converter Module

BUFF-4BNC/15D: Quad Output Buffer with single output per channel on four BNC Connectors or one 15-Pin D Connector

BUFF-4CH/(2)15D: Quad Output Buffer with dual outputs per channel on two 15-Pin D Connectors

Ordering Information

28144-<LP4FP|LP8FP|HP4F/LP4FP>-L

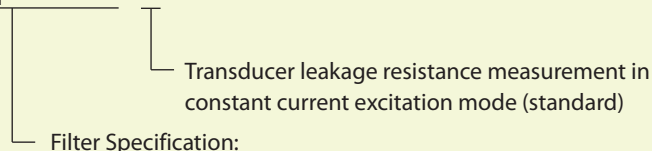

4-pole low-pass (LP4FP)

8-pole low-pass (LP8FP)

8-pole band-pass (HP4F/LP4FP)

BC6, BC7, BC8, BC9 Programmable Bridge Configuration Module:

One module is required per 28144 card to support bridge completion or shunt cal options.

Precision Product Solutions

For over 30 years Precision Filters has been a global provider of instrumentation for test measurements. You can rely on a single source for signal conditioning and switching—a *complete range of instrumentation*—products optimized to work together to provide high performance at reasonable cost.

Precision Products

Precision PF-1U-FA Multi-Channel Programmable Filter/Amplifier System



Exceptional desktop performance at low cost.

Ideal for conditioning low-level voltage inputs in front of high-resolution digital data acquisition systems. Fully programmable 8-channel and 16-channel configurations are available, both offering a choice of either 4- or 8-pole low-pass filters with programmable gain.

464kB High Density Programmable Switch Matrix



Computer controlled analog signal switching replaces tedious manual patch panels.

The 464kB is a reliable solid-state switch matrix system that provides computer-controlled connection between 256 inputs and 256 outputs, all in a single mainframe. Save time and reduce errors on test system setup. Download switch configurations from the host computer over the network. Built-in self-test with fault diagnostics.