

28104A QUAD-CHANNEL WIDEBAND BRIDGE CONDITIONER

Constant Voltage Excitation; 700 kHz Bandwidth

 PRECISION
FILTERS, INC.



SYSTEM 28000 FEATURES

- Graphical User Interface (GUI) for system control
- Intelligent gain and system scaling algorithms
- Test input and output monitor busses
- Go/no-go test with diagnostics to be used before tests
- Rigorous factory acceptance test for maintenance
- Field swappable AC power supplies
- Built-in temperature and power supply monitoring with alarms

28000 SIGNAL CONDITIONING SYSTEM

The Precision 28000 signal conditioning system provides all the flexibility you need to manage your test measurements.

The Precision 28000 makes it easy to manage a test with hundreds of channels and a mix of transducers. Choose charge, IEPE w/TEDS, voltage (filter amplifier), strain, thermocouple, RTD, potentiometer, current, frequency, or other transducers.

The built-in test hardware and software (optional) provide quick go/no-go tests which can be run before each test, and rigorous factory acceptance tests to assure you that the 28000 meets your most stringent requirements for critical applications. It won't be long before these tests earn a permanent place in your maintenance routine. And since they are traceable to NIST, they eliminate the need for off-site calibration.

In every phase of your tests—record keeping, installation, design, set-up, operation, maintenance and upgrading—the Precision 28000 offers ways to help you save time and money over the life of the system.

PRECISION 28104A APPLICATIONS

- Strain gage conditioner
- Load cell conditioner
- Pressure transducer conditioner
- Piezoresistive transducer conditioner
- General purpose bridge conditioner
- Potentiometer conditioner
- Low level AC or DC amplifier (<1 mV to 10 V inputs)
- Anti-aliasing filter/amplifier

PRECISION 28104A FEATURES

- 4 channels per card, 64 channels per chassis
- Balanced programmable constant voltage source with remote sense
- Up to 20 V excitation delivered to the bridge
- ± 10 V_{cm} operation
- Up to 200 kHz “filtered” bandwidth or 700 kHz “wide-band” bandwidth
- 2- to 10-wire plus shield transducer input interface
- Automatic bridge balance
- 4096 step bipolar shunt cal or single step bipolar resistive shunt cal; Shunt any bridge arm
- Switch selectable bridge configuration (1-arm, 2-arm, or 4-arm) with read back
- Programmable AC/DC input coupling
- Programmable amplifier: x1/16 to x8192 with 0.05% vernier
- 4 or 8-pole low-pass filters with filter bypass (wide-band)
- 2° phase matching between any channels
- Overload detection
- Precise automatic calibration
- Auxiliary front panel output connection to support the use of custom output modules



28104A Front Panel with Auxiliary Output Connector

28104A DESCRIPTION

The 28104A is a member of the Precision 28000 family of signal conditioners. The 28104A provides four channels of conditioning to support a wide variety of transducers including those that require constant voltage excitation in a bridge configuration such as strain gages and pressure transducers. The 28104A may be easily configured to operate as a precise voltage filter/amplifier on low-level AC or DC voltage inputs. Up to sixteen 28104A cards may reside in the 28000 system to provide up to 64 channels per chassis. In addition, the 28104A may be mixed with other conditioners in the 28000 family to meet your unique signal conditioning requirements.

The 28104A provides constant voltage excitation and conditioning for 1, 2, and 4-arm resistive bridges. The 28104A features automatic calibration of gain and offset for the entire channel, including the amplifier, filter, and excitation supply. The 2 to 10-wire input connection provides 6 wires for the bridge, 2 wires for shunt calibration, 1 wire for the shield, and 1 wire for single-arm bridges.

Precision bridge configuration resistors are contained on a plug-on module located on each 28104A card. The resistors may be set to complete the bridge for quarter, half, or full bridge configurations. ID registers are provided to read back bridge configuration and resistance.

Automatic balance of the bridge is accomplished by inserting a voltage ratiometric with the excitation supply to the amplifier input stage. This balance method provides outstanding stability without loading the bridge. A wide range of unbalanced conditions may be accommodated.

Two methods of shunt calibration are available. The BC1 voltage insertion technique provides 4096 steps of bipolar shunt calibration that may be used to simulate a bridge unbalance. The BC2 shunt calibration supports the use of precision resistors for bipolar single-step shunt cal. For either technique, the 28104A supports the use of dedicated shunt cal lines to the bridge that allow the user to perform the shunt cal on non-current carrying leads. Single shunt calibration of any arm of the bridge and the double shunt calibration of opposing bridge arms are supported. Also, since the bridge balance technique is non-invasive to the bridge, shunt calibration results are unaffected by bridge balance circuitry.

Balanced Voltage Excitation

The 28104A features a programmable constant voltage excitation supply that can source up to 20 volts to the bridge. Balanced constant voltage excitation offers a number of advantages over single-ended excitation. It enables a true balanced instrumentation amplifier input for outstanding rejection of high frequency common-mode signals. Single-ended voltage excitation to balanced bridges produces a relatively large common-mode voltage at half the excitation supply. The instrumentation amplifier must reject this signal. Balanced voltage excitation applied to balanced bridges results in lower common-mode input voltages to the amplifier input stage.

The excitation supply has automatic amplitude and offset correction that may be run on the unit in place at any time. Dedicated remote sense lines allow the excitation supply regulator to deliver an accurate voltage to the bridge.

Input Stage

The 28104A input stage has 120 dB of common-mode rejection, low DC drift and ultra-low noise (< -163 dBV/ $\sqrt{\text{Hz}}$). The input is equipped with programmable AC/DC coupling. AC coupling is useful in applications where DC levels, that limit dynamic range, can be coupled out of the AC signal.

A programmable switch at the input stage is provided to connect the amplifier to the 28000 system test bus. The test bus is used to inject signals for performance verification. In addition, the excitation supply may be connected to the input stage for direct verification of the excitation supply level.

Amplifier and Filter

Programmable pre- and post-filter amplifiers provide an overall gain of 8,192. Gain is distributed both before and after the filter to provide protection from large out-of-band energy or transients that could cause clipping before the filter, distorting the data. The Gain Wizard in the GUI allows the user to set a gain reserve and then apportions the gain between the input and output. This provides input gain for best noise performance yet conforms to the limitations of the user's worst case estimate of out-band or transient signals. Overload detectors alert the user to over-voltage conditions.

The post-filter gain has resolution of better than 0.05% to enable precise system scaling of the 28104A outputs to match the full-scale input of the external recording device, given the transducer sensitivity and fullscale input in measurement units. A fully buffered output having over 20 mA of drive capability may be used to drive long output cable runs.

The 28104A contains a 4- or 8-pole low-pass filter with cutoffs programmable from 1 Hz to 204.6 kHz and programmable "flat" or "pulse" mode. The "flat" mode provides pass-band characteristics nearly identical to a Butterworth filter while providing a much sharper roll-off. This mode is a good choice for applications such as spectral analysis. The "pulse" mode has time domain response similar to the Bessel filter yet provides superior amplitude response characteristics. The "pulse" mode is ideal for time domain applications including transient (shock) measurements and time domain waveform analysis.

28104A PROGRAMMABLE FEATURES

- Excitation level (0 to 20.475 V in 5 mV steps)
- Excitation sense (local or remote)
- Bridge configuration (1-arm, 2-arm, or 4-arm)
- Automatic balance (zero)
- AC/DC coupling
- Test Modes: Amp Short, Excitation Off, Voltage Substitution, Shunt Calibration, Excitation Monitor, Output Monitor
- Gain (x1/16 to x8192 with 0.05% resolution)
- Cutoff frequency: 1 Hz to 102.3 kHz, pulse mode
2 Hz to 204.6 kHz, flat mode
- Wideband (700 kHz) or filtered operation
- Shield (open or grounded)

GRAPHICAL USER INTERFACE DISPLAY

All programmable features in addition to:

- Bridge configuration and resistance read back
- Balance (zero) status
- Input wiring
- Gage sensitivity
- System scaling in engineering units
- Overload status
- Gain Wizard
- Filter Wizard
- Group Control

28104A CONDITIONER CARDS

The detailed description and specifications for the 28104A card are organized as follows in the sections below.

- Card Model Number Structure
- Bridge Configuration Module with Shunt Cal Module
- Bridge Resistive Modules
- Bridge Wiring
- Excitation Supply
- Input Characteristics and Options
- Amplifier Characteristics
- Test Modes
- Filter Type Characteristics
- Output Characteristics
- General Card Characteristics
- Accessories and Ordering Information

28104A CARD MODEL NUMBER

The 28104A card model number describes the configuration of the four channels on the card. The model number identifies the filter characteristic, or filter type, of the low-pass filters.

28104A-Filter Type

LP4FP (4-pole low-pass)

LP8FP (8-pole low-pass)

BRIDGE CONFIGURATION & SHUNT CAL MODULE

One plug-on bridge configuration and one shunt cal module must be specified for each 28104A card (except that bridge configuration modules are not required for 4-arm bridge configurations with no shunt calibration).

The bridge configuration cards provide selectable or hardwired bridge configuration. Three versions are available: BC1 for 4096-step shunt cal, BC2 for resistive shunt cal, and BC0 for no shunt cal. Option V on the bridge completion module provides a 26 VDC power source at the card input connections. The GUI reads back and reports the model number from the plug-on card.

BC1 Shunt Cal provides shunt calibration utilizing voltage insertion at the bridge, providing 4096 steps of shunt calibration. Single shunt of any bridge arm or double shunt of opposing arms may be selected. The shunt may be applied at the gage (if additional cable wires are used) or at the signal conditioner via program control. Double shunt sensitivity is set by a precision resistor on the BR1 resistor completion card and is programmable to ± 16 mV/V in steps of $7.8125 \mu\text{V/V}$. This simulates compression or tension on the gage.

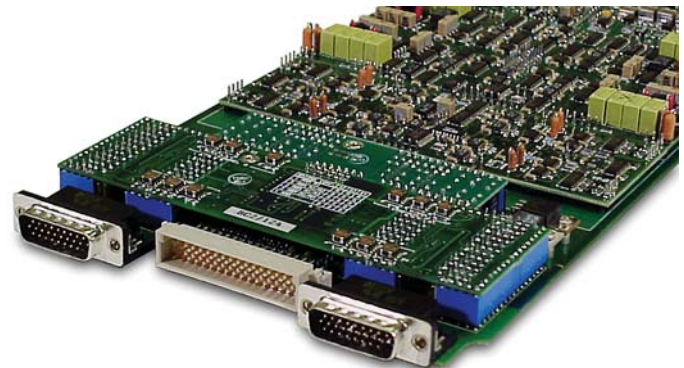

The 28104A Card with Bridge Configuration Module.

BRIDGE CONFIGURATION & SHUNT CAL MODULE (Continued)

BC2 Shunt Cal provides single-step bipolar shunt cal using a precision resistor installed on the BR2 resistor completion card. Programmable GUI selections allow the shunt to be applied at the gage (if additional cable wires are used) or at the signal conditioner. Single shunt of any bridge arm, or double shunt of opposing bridge arms may be selected. Upscale (tension) and downscale (compression) cals are selectable from the GUI.

The standard BC2 shunt cal supplied with 120Ω, 350Ω and 1KΩ cards produces 5 mV/V single shunt or 10 mV/V double shunt in bridge output with accuracy better than 0.01%. Custom shunt resistor values may be specified, or the user can install shunt resistor values.

Note: Bridge configuration modules are not required for 4-arm bridge configurations with no shunt calibration.

Modules without Shunt Cal Options

BC0/124	Selectable bridge configuration, no shunt cal
BC0/1	Hardwired for 1-arm (R1) bridge, no shunt cal
BC0/2	Hardwired for 2-arm (R1/R2) bridge, no shunt cal

Modules with 4096-Step Shunt Cal Options

BC1/124	4096-step shunt cal with selectable bridge configuration
BC1/1	4096-step shunt cal, hardwired for 1-arm (R1) bridge
BC1/2	4096-step shunt cal, hardwired for 2-arm (R1/R2) bridge
BC1/4	4096-step shunt cal, hardwired for 4-arm bridge

Modules with Resistive Shunt Cal Options

BC2/124	Single-step bipolar resistive shunt with selectable bridge configuration
BC2/1	Single-step bipolar resistive shunt, hardwired for 1-arm (R1) bridge
BC2/2	Single-step bipolar resistive shunt, hardwired for 2-arm (R1/R2) bridge
BC2/4	Single-step bipolar resistive shunt, hardwired for 4-arm bridge

Option V 26V DC supply at input connectors

Bridge Configuration Diagram

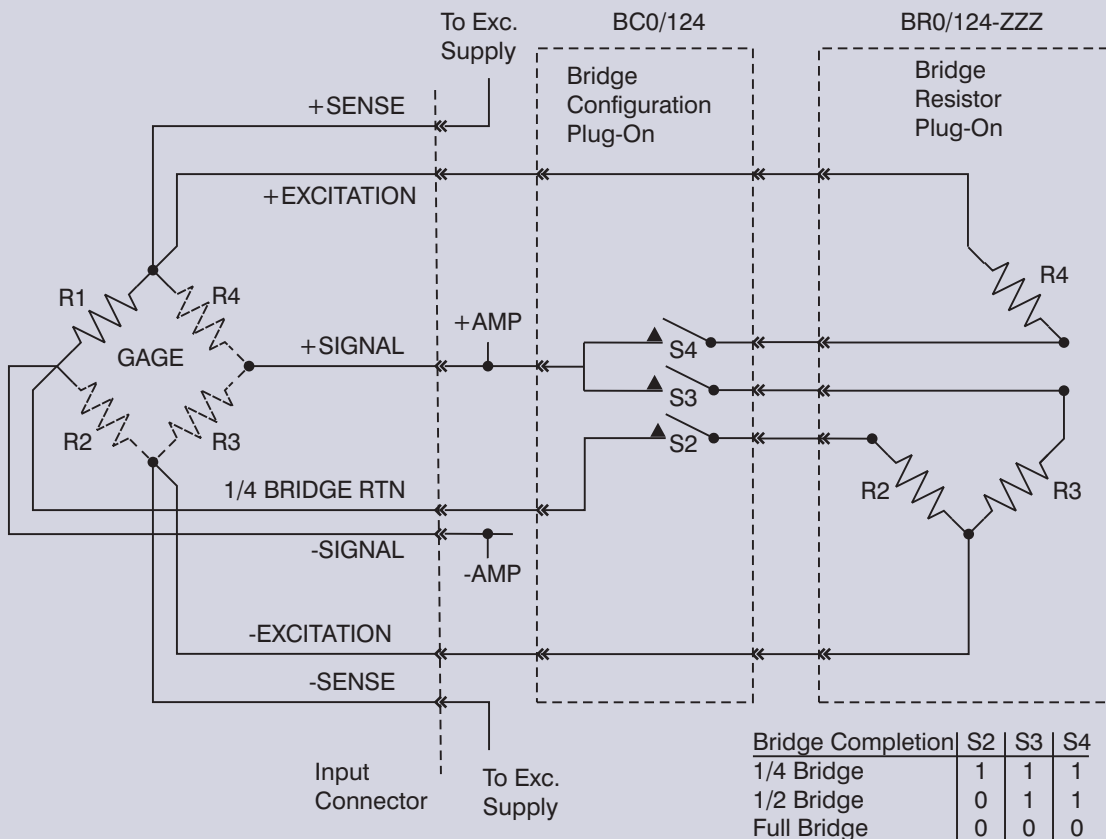

BC0/124 with BR0/124-XXX

BRIDGE RESISTOR MODULES

Optional plug-on bridge resistor completion modules provide high stability completion resistors for standard bridges. This plug-on also provides the shunt cal scaling resistor for models with 4096-step shunt for BC1 models, or the precision shunt resistor for BC2 models. Resistor values can be read back and displayed on the GUI.

The Bridge Resistor modules are not included with the 28104A card and must be specified separately. The module provides the completion and shunt cal resistors for four channels.

There are three base models: BR1 for use with BC1 configuration cards, BR2 for use with BC2 configuration cards, and BR0 for configurations with no shunt calibration.

Note: Bridge resistor modules are not required for hardwired 4-arm bridge configurations with no shunt calibration.

Resistor Temp. Coef.: $\pm 4 \text{ ppm}/^\circ\text{C}$
 Resistor Accuracy: $\pm 0.01\%$

For a complete list and description of the individual bridge resistive modules see the following page.

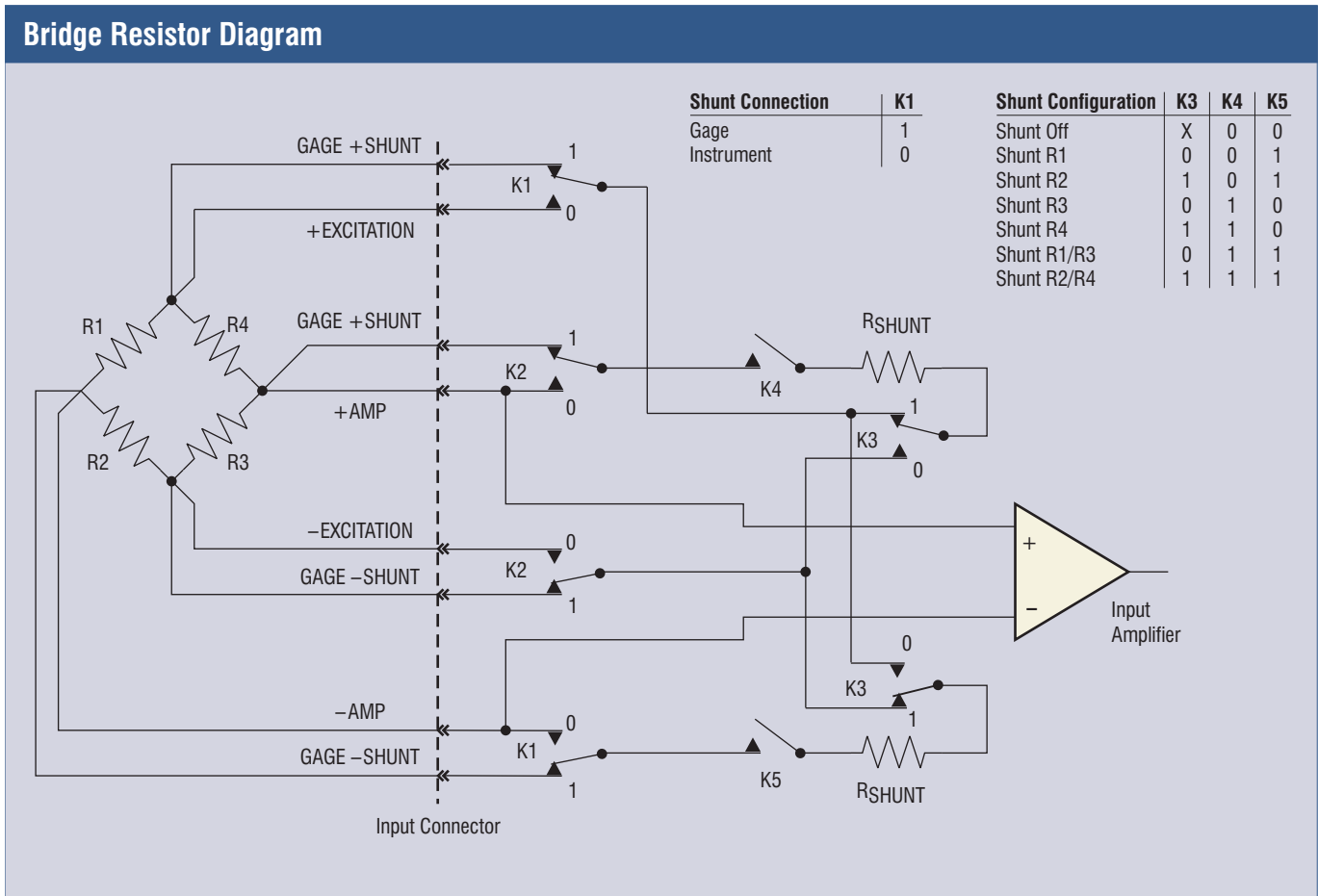

BC2/X Shunt Cal

BRIDGE RESISTOR MODULES (Continued)

BR0 No Shunt Cal

BR0/124-120	120 Ω completion for 1, 2, or 4-arm bridges. No shunt cal.
BR0/124-350	350 Ω completion for 1, 2, or 4-arm bridges. No shunt cal.
BR0/124-1K0	1 k Ω completion for 1, 2, or 4-arm bridges. No shunt cal.
BR0/124-ZZZ	Custom completion for 1, 2, or 4-arm bridges. No shunt cal.

BR1 4096-Step Shunt Cal without Completion Resistors

BR1/4-XXX-3690	4-arm bridge configuration (no completion resistors). 4096-step shunt cal scaling resistor.
BR1/4-XXX-10762	4-arm bridge configuration (no completion resistors). 4096-step shunt cal scaling resistor.
BR1/4-XXX-30750	4-arm bridge configuration (no completion resistors). 4096-step shunt cal scaling resistor.
BR1/4-XXX-YYY	4-arm bridge config. (no completion Resistors). YYY = Custom 4096-step shunt cal scaling resistor.

BR1 4096-Step Shunt Cal with Completion Resistors

BR1/124-120-3690	120 Ω completion for 1, 2, or 4-arm bridges. 4096-step shunt cal scaling resistors.
BR1/124-350-10762	350 Ω completion for 1, 2, or 4-arm bridges. 4096-step shunt cal scaling resistors.
BR1/124-1K-30750	1 k Ω completion for 1, 2, or 4-arm bridges. 4096-step shunt cal scaling resistors.
BR1/124-ZZZ-YYY	Custom completion for 1, 2, or 4-arm bridges. YYY = custom 4096-step shunt cal scaling resistors.

BR2 Single-Step Shunt Resistor without Completion Resistors

BR2/4-XXX-5940	4-arm bridge config. (no completion resistors). Single-step shunt resistors.
BR2/4-XXX-17325	4-arm bridge config. (no completion resistors). Single-step shunt resistors.
BR2/4-XXX-49500	4-arm bridge config. (no completion resistors). Single-step shunt resistors.
BR2/4-XXX-YYY	4-arm bridge config. (no completion resistors). YYY = Custom single-step shunt cal scaling resistors.

BR2 Single-Step Shunt Resistor with Completion Resistors

BR2/124-120-5940	120 Ω completion for 1, 2, or 4-arm bridges. Single-step shunt cal resistors.
BR2/124-350-17325	350 Ω completion for 1, 2, or 4-arm bridges. Single-step shunt cal resistors.
BR2/124-1K-49500	1 k Ω completion for 1, 2, or 4-arm bridges. Single-step shunt cal resistors.
BR2/124-ZZZ-YYY	Custom completion for 1, 2, or 4-arm bridges. YYY = Custom single-step shunt cal scaling resistors.

XXX = No completion resistors

ZZZ = Custom completion resistor, Consult factory

YYY = Custom shunt cal resistor, Consult factory

Shunt cal resistors specified for 16 mV/V of excitation fullscale range for double shunt on BC1 shunt cal or 10 mV/V for double shunt on BC2 shunt cal.

BRIDGE WIRING

Input Connector: 26-pin D-shell (2 ea.)

Input Wires: EXCITATION (2)
SENSE (2)
SIGNAL (2)
SHUNT CAL (4)
RETURN (1) Single Arm Bridge
SHIELD (1)

28104A EXCITATION SUPPLY

Programmable Constant Voltage Excitation

- Maximum Output: 20.475 V, 30 mA (balanced)
- Steps: Programmable from 0 to 20.475 V in 5 mV steps
- Excitation Sense: Programmable (local or remote sense)
- Accuracy: ± 5 mV, $\pm 0.1\%$
- Current Limit: 60 mA, typical
- Load Regulation: $\pm 0.03\%$ or $\pm 200 \mu\text{V}$, whichever is greater, no load to full load
- Noise: $100 \mu\text{V}_{\text{rms}}$, 3 Hz to 100 kHz
- Temp. Drift: $\pm 0.0025\%/^{\circ}\text{C}$ of setting or $\pm 50 \mu\text{V}/^{\circ}\text{C}$, whichever is greater
- Sense Current: Less than $10 \mu\text{A}$
- Calibration: Automatically calibrated for gain and offset. Calibration initiated at the GUI panel.
- Excitation Off: The excitation supply is programmed to 0 volts.

Excitation Monitor (Standard)

Excitation Monitor: Under GUI control, the amplifier input is switched from the bridge to the excitation supply to monitor the excitation voltage. Excitation monitor gain is $\times 0.5$.

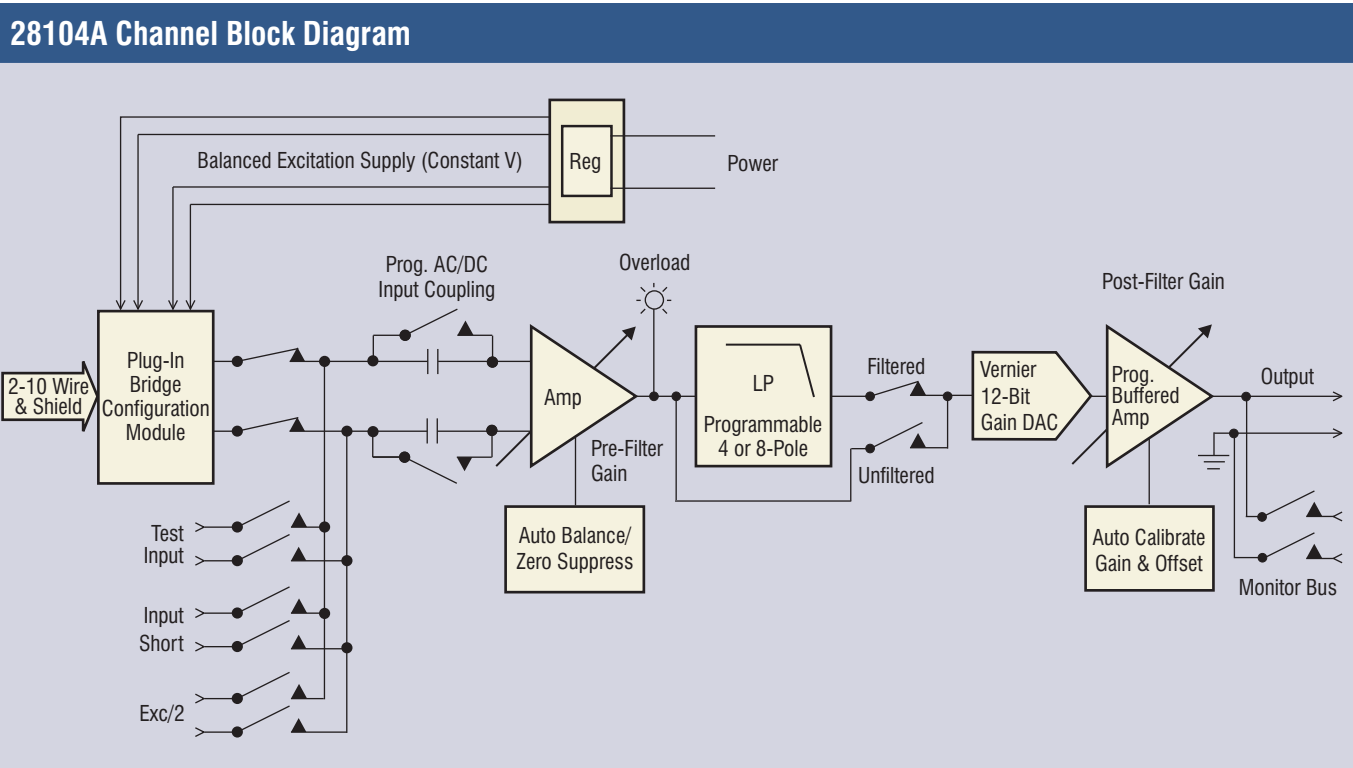

28104A Channel Block Diagram

28104A INPUT CHARACTERISTICS

Common-Mode Voltage:

±10 V operating

CMRR: 110 dB max, 120 dB typical,
DC to 60 Hz, with a full bridge
input and input gain of x8 or greater

Input Protection: ±50 V continuous
±100 Vpk transient, 1 ms pulse
10% duty cycle

Input Impedance: 10 MΩ//100 pF per side
20 MΩ//50 pF differential
100 MΩ//200 pF common mode

Max Level: ±10 Vpk for $f \leq 200$ kHz;
±10 Vpk (200 kHz/f) for $f > 200$ kHz

Offset Drift: 1 $\mu\text{V}/^\circ\text{C}$, typical

Noise: 7 $\text{nV}/\sqrt{\text{Hz}}$ RTI at 1 kHz and gain $> \times 64$

Shield: Programmable (open or grounded)

Programmable AC/DC input coupling:

Note: Specs below are for AC-coupled
setting.

Impedance: (0.1 μF & 10 MΩ)//100 pF per side
(0.159 Hz)

CMRR: 90 dB, 60 Hz and input gain of x8
or greater

Input Short (Standard)

Input Short: A switch at the amplifier input is
used to ground the input stage to
measure amplifier noise and DC offset.

Test Input (Standard)

Test Input: Test input allows for injection of a test
signal. An external test signal or the
28000-?-TEST Test System may be
connected at the rear panel. Refer to the
28000-?-TEST Test System specifica-
tion for more information.

Auto Bridge Balance/Zero Suppress (Standard)

Auto Bridge Balance Mode:

The bridge is automatically balanced
utilizing voltage insertion at the input
amplifier when bridge balance mode is
selected. The inserted voltage is derived
from and thus tracks the excitation sup-
ply. A successive approximation A/D
converter mechanization is used for
rapid bridge balance.

Range: Bridge balance algorithm selects the
most appropriate range to achieve
balance with finest resolution. Ranges
are: 512 mV/V of excitation or
64 mV/V and 8 mV/V

Resolution: ±0.05% of span

Temp Coef.: ±50 ppm/°C

Auto Balance Time: Less than 15 seconds per system of
64 channels.

Auto Suppress Mode:

A programmable DC offset derived from
a precision 10 V reference is injected at
the channel input stage to suppress the
gage DC operating voltage. Manual or
automatic suppression modes are
supported.

Ranges: -159.92 mV to +160 mV
in 78 μV steps

-1.2794 V to +1.28 V
in 625 μV steps

-10.235 V to +10.24 V
in 5 mV steps

Accuracy: 0.25% of setting +5 mV

Auto Suppress Time: <15 seconds per 64 channel system

28104A AMPLIFIER CHARACTERISTICS

Pre-filter Gain:	x1 to x512 in binary steps with over-load detection (10.5 Vpk threshold)
Post-filter Gain:	x1/16 to x16 in binary steps with vernier adjustment of 0.05% of setting
DC Accuracy:	0.1% after auto cal at any gain setting
Stability:	±0.02% for 6 months
Temp Coef.:	±0.004%/°C
DC Linearity:	±0.005% re Fullscale, relative to the best straight line
Freq. Response:	DC to 100 kHz, 0 dB ±0.1 dB
	200 kHz, 0 dB to ±0.15 dB
-3.01 dB BW:	700 kHz, typical
High Freq. Rolloff:	18 dB/octave

28104A TEST MODES

Shunt Cal: Applies shunt to bridge.

Excitation Monitor: The amplifier input is switched from the bridge to the excitation supply to monitor the excitation voltage. Excitation monitor gain is x0.5.

Excitation Off: The excitation supply is programmed to zero volts.

Amplifier Short: A switch at the amplifier input is utilized to ground the input stage for measurement of noise and DC offset.

Test Bus: Test input allows for injection of a test signal. An external test signal or the 28000-?-TEST Test System may be connected at the rear panel. Refer to the 28000-?-TEST Test System specification for more information.

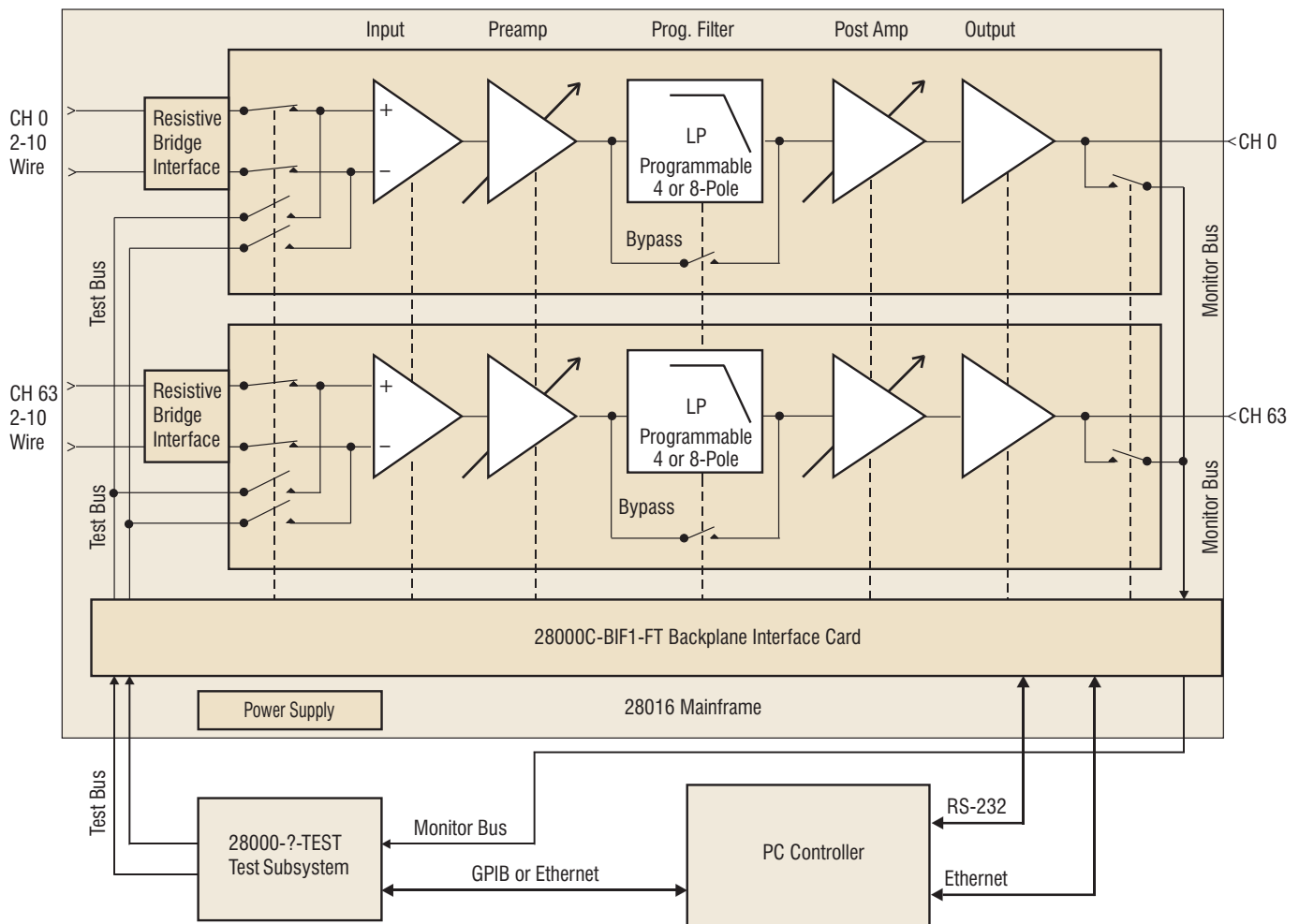

System Block Diagram

28104A FILTER CHARACTERISTICS

Option LP4FP:

4-pole, 4-zero low-pass filter. Programmable for maximally flat pass-band (LP4F) or linear phase with optimized pulse response (LP4P).

Option LP8FP:

8-pole, 8-zero low-pass filter. Programmable for maximally flat pass-band (LP8F) or linear phase with optimized pulse response (LP8P).

Custom Filters:

Other filters characteristics and cutoff frequencies are available including Butterworth and Bessel types. Please consult with factory for more information.

Cutoff Frequencies:

Flat Mode: 2 Hz to 2.046 kHz in 2 Hz steps
2.2 kHz to 204.6 kHz in 200 Hz steps

Pulse Mode: 1 Hz to 1.023 kHz in 1 Hz steps
1.1 kHz to 102.3 kHz in 100 Hz steps

LP4F, LP4P, LP8F, LP8P:

Amplitude Accuracy: ± 0.1 dB max, DC to 0.8 Fc
 ± 0.2 dB max, 0.8 Fc to Fc

Amplitude Match: ± 0.1 dB max, DC to 0.8 Fc
 ± 0.2 dB max, 0.8 Fc to Fc

Phase Match: $\pm 1^\circ$ max, DC to 0.8 Fc
 $\pm 2^\circ$ max, 0.8 Fc to Fc

Specification	LP4F Maximally Flat Low-Pass Filter	LP4P Constant Time Delay Low-Pass Filter	LP8F Maximally Flat Low-Pass Filter	LP8P Constant Time Delay Low-Pass Filter
Cutoff Frequency Amplitude	-3.01 dB	-3.01 dB	-3.01 dB	-3.01 dB
DC Gain	0.00 dB	0.00 dB	0.00 dB	0.00 dB
Pass-Band Ripple	0.00 dB	0.00 dB	0.00 dB	0.00 dB
Stop-Band Frequency	5.9465 Fc	11.863 Fc	1.7479 Fc	3.4688 Fc
Cutoff Frequency Phase	-180.0 deg	-101.5 deg	-360 deg	-161.9 deg
Phase Distortion (DC to Fc)	< 31.8 deg	< 3.7 deg	< 102 deg	< 0.05 deg
Zero Frequency Group Delay	0.4117/Fc	0.2920/Fc	0.7197/Fc	0.4496/Fc
Percent Overshoot	11.1%	0.5%	18.9%	1.1%
1% Settling Time	1.65/Fc	0.66/Fc	4.03/Fc	1.25/Fc
0.1% Settling Time	2.72/Fc	0.77/Fc	7.02/Fc	2.25/Fc
-0.1 dB Frequency	0.635 Fc	0.182 Fc	0.8538 Fc	0.1800 Fc
-1 dB Frequency	0.8487 Fc	0.5741 Fc	0.9437 Fc	0.5685 Fc
-2 dB Frequency	0.9370 Fc	0.8129 Fc	0.9772 Fc	0.8087 Fc
-3.01 dB Frequency	1.0000 Fc	1.0000 Fc	1.0000 Fc	1.0000 Fc
-20 dB Frequency	1.7412 Fc	3.0248 Fc	1.2149 Fc	2.2342 Fc
-40 dB Frequency	2.9555 Fc	5.6932 Fc	1.4443 Fc	2.7556 Fc
-60 dB Frequency	4.5986 Fc	9.0980 Fc	1.6391 Fc	3.2016 Fc
-80 dB Frequency	5.9465 Fc	11.8629 Fc	1.7479 Fc	3.4688 Fc

28104A OUTPUT CHARACTERISTICS

Type: DC-coupled, single-ended output.
Programmable wideband (700 kHz)
or filtered.

Z: $10\ \Omega$ shunted by 100 pF

Max Output: $\pm 10\ \text{Vpk}$, $\pm 20\ \text{mApk}$

Offset Drift: $1\ \mu\text{V}/^\circ\text{C}$, RTI + $150\ \mu\text{V}/^\circ\text{C}$, RTO, typ

Noise: $3\ \mu\text{Vrms}$ RTI + $300\ \mu\text{Vrms}$ RTO, typ
1 Hz to 200 kHz

Crosstalk: $-80\ \text{dB}$, DC to 25 kHz between
adjacent channels with the same
configuration and programmed settings.

Auto-Offset Adjust (Standard)

Auto-Offset: Auto-offset automatically zeroes offset at the channel output to less than 5 mV at any gain setting. The auto-offset cycle is initiated in the GUI. The offset DAC settings are stored in non-volatile memory on the card for every gain setting. Changes in gain result in minimal disruption of the channel.

Output Monitor (Standard)

Output Monitor: A switch located at the output of each channel allows for multiplexed connection to the mainframe output monitor bus. The output monitor bus is available at a connector located in the 17th slot at the rear of the mainframe. The monitor function is used by the 28000-?-TEST Test System or is available to the user for viewing channel outputs.



28016-M3 Mainframe Front Panel



28008-M3 Mainframe Front Panel

28104A CARD GENERAL CHARACTERISTICS

28104A Card Size: 6.63 x 17.5 x 0.75 inches

Card Weight: 1.4 lb. net

Temperature: 0° to 40° C (operating)
-20° to 70° C (storage)

ORDERING INFORMATION

28104A-Filter Type

LP4FP (4-pole low-pass)
LP8FP (8-pole low-pass)

Note: For bridge completion and shunt cal options, a BR?? Bridge Resistor Module and BC?? Bridge Completion Module must be ordered in addition to the base 28104A card.

ACCESSORIES

Input Mating Connectors

The input connectors are integral to the 28104A. Cutouts on the 28000 frames allow for the input connector to pass through the backplane to directly mate with the input cable. Two connectors required per slot (4 channels).

CONN-IN-26D-MTL: High-Density 26-pin D-shell mating connector with machined crimp pins and backshell with large cable opening and strain relief.

CONN-IN-26D-SC-MTL: High-Density 26-pin D-shell mating connector with machined solder cup pins and backshell with large cable opening and strain relief.

Output Mating Connectors

The 28016-M3 mainframe contains four 50-pin D-shell connectors mounted on the rear panel. The 28008-M3 frame provides two 50-pin D-shell connectors. Sixteen twisted pairs are accommodated per connector. One output mating connector is required per 16 channels (i.e., a set of four card slots).

CONN-OUT-50D: 50-pin D-shell mating connector with crimp pins and backshell with strain relief.

CONN-OUT-50D-SC: 50-pin D-shell mating connector with solder cup pins and backshell with strain relief.

Output Buffer Modules

The 28104A front panel auxiliary output connector accommodates Precision Filters output adapter modules to provide multiple buffered outputs per channel. Refer to the 28000 Output Buffer Module specification sheet for more information.

28000-RMS/DC4 Output Module: Quad channel RMS-to-DC converter module.

BUFF-4BNC/15D: Quad output buffer with single output per channel on four BNC connectors and one 15-pin multipin connector.

BUFF-4CH/(2)15C: Quad output buffer with dual outputs per channel on two 15-pin connectors.

